

The PRO-EHJ is designed for use on commercial/industrial sectional doors with high or vertical lift track and rolling doors and grilles.

STANDARD FEATURES

- 2 year Warranty
- **Control Circuit (2 options)**
- * **1- (M)** Heavy duty reversing contactor with mechanical & electrical interlock incorporating the new UL325 (2010) Interface Module.
 - *C2 factory wiring standard (constant pressure close), B2 wiring can be field set by moving 1 jumper and installing Micanan monitored fail safe photo-eyes (supplied) or (optional) Micanan compatible monitored fail safe electric edge
- 2-** Heavy duty reversing contactor with mechanical & electrical interlock. (Not available in US or other areas where UL325 (2010) is mandated) C2 factory wiring standard, B2 wiring can be field set by moving 1 jumper. Provisions for standard reversing devices.
- 24V class 2 control circuit with 40VA transformer to protect against short circuit
- External radio control terminal strip
- Low friction powder metal limit cam nuts with fully adjustable rotary type limit switch assembly
- Three button open-close-stop control station Nema-1
- Continuous duty industrial motor with overload protection
- Motor removable without affecting limit settings
- Heavy duty 5L V-belt
- #41 roller chain & sprockets on all internal drives
- Adjustable friction clutch
- Mechanical brake system
- Solenoid brake (optional PRO EHJB)
- #50 roller chain and sprockets on final drive
- 3/4" permanently lubricated & sealed ball bearings on pulley shaft
- 1" permanently lubricated & sealed ball bearings on final drive shaft
- Emergency chain hoist with electrical cut-out switch for manual operation
- Internal load sensing feature that will detect a locked or jammed door and stop unit from operation
- Provides for egress to allow for opening of a grill by manual operation or spring tension (optional egress device)
- Left or right hand mounting(must specify at time of order)
- Baked on dark grey coat finish
- Shipping weight 95 lbs



Commercial/Industrial continuous duty belt drive jackshaft operator with emergency chain hoist, load sensing device and emergency egress capability

When ordering a PRO-EHJ operator, supply Micanan with the following information

- Door height
- Door width
- Type of door
- Horsepower
- Voltage/Phase
- Safety devices
- Door shaft diameter & door shaft key size
- Mounting (LH or RH, Bracket or Wall mount)
- Options

MECHANICAL DIMENSIONS

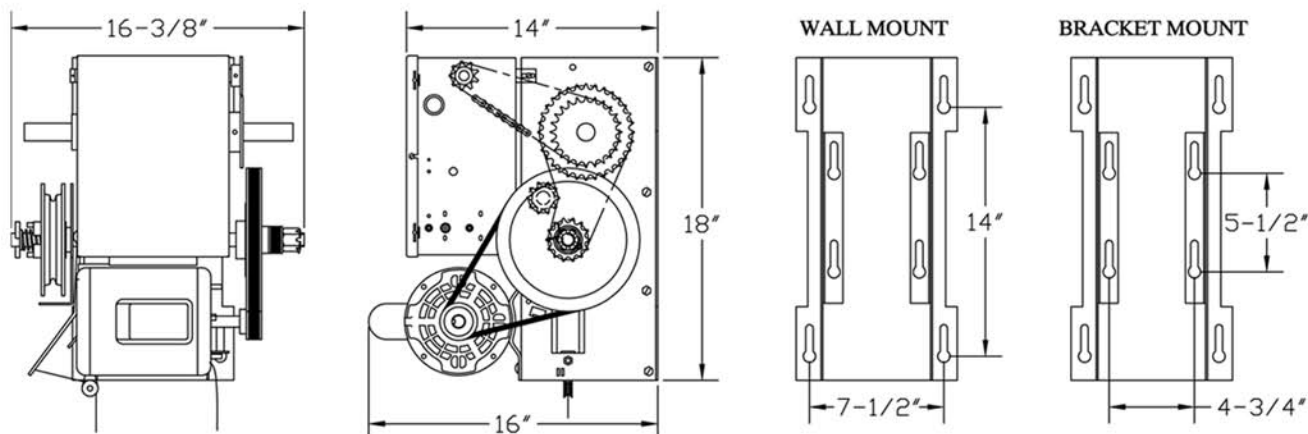

FOR MORE INFORMATION, PLEASE VISIT WWW.MICANAN.COM OR CONTACT US AT

MICANAN HEAD OFFICE: 1380 St-Regis Blvd. Dorval, QC H9P 2T5 Canada | Tel: (514) 822-1116 | Toll-Free: 1-877-888-1116 | Fax: (514) 822-1118 | Toll-Free: 1-877-888-1118

MICANAN PHOENIX: 1236 W. Southern Ave. Suite 104 Tempe, Arizona USA 85282 | Tel: (480) 557-0070 | Toll-Free: 1-888-816-8584 | Fax: (480) 557-8488

MICANAN ATLANTA: 2885 N. Berkeley Lake Rd Suite 7 Duluth, Georgia USA 30096 | Tel: (678) 584-2543 | Toll-Free: 1-800-798-2543 | Fax: (678) 584-2544