

OWNER'S MANUAL

STRONGARM™ TL85 VEHICLE RESTRAINT WITH BLUE GENIUS™ TOUCH CONTROL



WARNING

Do not operate or service this product unless you have read and fully understand the entire contents of this manual. Failure to do so may result in property damage, bodily injury or death.

BLUE GIANT®

TABLE OF CONTENTS

1.0	ABOUT THE STRONGARM™ TL85 WITH BLUE GENIUS™ TOUCH CONTROL	4
1.1	OWNER'S PURCHASE RECORD	4
2.0	INTRODUCTION	5
2.1	WARRANTY INFORMATION	5
2.2	EXCLUSION OF LIABILITY	5
2.3	MANUFACTURER'S NOTE	5
2.4	OWNER'S RESPONSIBILITY	6
3.0	SAFETY MESSAGE COLOR IDENTIFICATION	7
3.1	OPERATIONAL SAFETY WARNINGS	7
4.0	LOCKOUT / TAGOUT PROCEDURE AND RULES	8
5.0	EMERGENCY VEHICLE RESTRAINT LOWERING PROCEDURE	8
6.0	CONTROL PANEL OPERATION	9
6.1	BUTTON FUNCTION	9
7.0	OPERATING INSTRUCTIONS	10
7.1	FUNCTIONAL DESCRIPTION	10
7.2	STOP BUTTON FUNCTION	11
7.3	PRIOR TO USE: EQUIPMENT IN STORED POSITION	11
7.4	TRAILER AT BAY	12
7.5	ENGAGING RESTRAINT	12
7.6	DEPLOYING THE DOCK LEVELER	13
7.7	RELEASING THE RESTRAINT ARM	13
8.0	ENGAGING THE OVERRIDE FEATURE	14
8.1	RELEASING THE OVERRIDE FEATURE	15
9.0	MAINTENANCE	16
9.1	PLANNED MAINTENANCE PROGRAM (PMP)	16
9.2	OPERATOR DAILY INSPECTION	16
9.3	ROUTINE SERVICING AND MAINTENANCE	16
9.4	PLANNED MAINTENANCE PROGRAM INTERVALS	16
9.5	MAINTENANCE SEQUENCE	16
9.6	RECOMMENDED HYDRAULIC FLUIDS	16
9.7	DAILY MAINTENANCE PROCEDURES CHECKLIST - STRONGARM™ TL85 VEHICLE RESTRAINT	17
10.0	POWERPACK CONFIGURATIONS	18
11.0	RECOMMENDED SPARE PARTS	19
11.1	STANDARD OPERATIONAL COMPONENTS	19
11.2	COMPONENT SHIELDS	20
12.0	DECAL IDENTIFICATION AND LOCATION	21
13.0	EQUIPMENT COMPONENT ILLUSTRATIONS	22
13.1	COMPONENTS AS SHIPPED CHECKLIST	22

TABLE OF CONTENTS CONT'D.

13.2	MECHANICAL ASSEMBLY - 53-013732	23
13.3	ARM LOCK AND PRESSURE SWITCH ASSEMBLY - 51-003116	24
13.4	GENERAL DIMENSIONS	25
13.5	POWERPACK PART IDENTIFICATION - REMOTE WALL-MOUNTED	26
13.6	POWERPACK PART IDENTIFICATION - REMOTE PIT-MOUNTED	27
13.7	CONTROLS	28
13.8	JUNCTION BOX WITH REMOTE I/O - REMOTE WALL-MOUNTED POWERPACK	29
13.9	JUNCTION BOX WITH REMOTE I/O - REMOTE PIT-MOUNTED POWERPACK	29
13.10	JUNCTION BOX HARNESS	30
13.11	JUNCTION BOX DIMENSIONS	30
13.12	RESTRAINT INTERLOCK SENSOR	31
13.13	EXTERIOR TRAFFIC LIGHT / MIRROR IMAGE SIGN	31
14.0	ALTERNATIVE POWERPACK OPTIONS	32
14.1	MECHANICAL ASSEMBLY (SELF-CONTAINED POWERPACK) - 51-013731	32
15.0	VEHICLE RESTRAINT TROUBLESHOOTING	33
16.0	BLUE GENIUS™ LCD MESSAGES	35
17.0	WIRING DIAGRAMS	35
17.1	WIRING DIAGRAM—115V SINGLE PHASE	36
17.2	WIRING DIAGRAM—230-575V THREE PHASE	37
17.3	WIRING DIAGRAM—SELF-CONTAINED POWERPACK—115V SINGLE PHASE	38
17.4	WIRING DIAGRAM—SELF-CONTAINED POWERPACK—230-575V THREE PHASE	39

1.0 ABOUT THE STRONGARM™ TL85 WITH BLUE GENIUS™ CONTROL

The Blue Giant StrongArm™ TL85 applies 32,000 lb (14,545 kg) of restraining force to prevent trailer creep, unscheduled departures, and other hazards caused by trailer movement. With a vertical restraining range of 12" (305mm) to 26" (660mm) and horizontal reach of 11 3/4" (298mm), the TL85 will secure virtually any truck or trailer, even those with bent or damaged ICC bars. The TL85 comes equipped with VersaLock™ securing technology, which enables the restraint arm to lock at any angle within a 45° to 90° arc.

The Blue Genius™ Gold Series II Touch Control Panel features include an LCD menu screen, audible function (ENGAGE, RELEASE, STOP) buttons and a flat-surface keypad with unique touch sensors. LED interior traffic lights integrated in the Blue Genius™ Touch Control Panel and LED exterior traffic lights keep truck drivers and warehouse personnel advised of safety conditions during dock operations.

1.1 OWNER'S PURCHASE RECORD

OWNER'S PURCHASE RECORD
Please record information for future inquiries and to validate warranty. (See Section 2.1 for warranty validation)

Dealer:	Date in Service:
	Number of Units:
Serial Number:	Door #:
Serial Number:	Door #:
Serial Number:	Door #:
Serial Number:	Door #:
Serial Number:	Door #:
Serial Number:	Door #:
Serial Number:	Door #:
Serial Number:	Door #:
Serial Number:	Door #:

The manufacturer offers a full line of dock levelers, dock safety equipment, accessories, ergonomic and scissor lift equipment, seals and shelters, and industrial trucks. Concurrent with a continuing product improvement program, specifications are subject to change without notice (see section 2.2 "Exclusion of Liability" for more details). Please contact the manufacturer for latest information. Some features illustrated may be optional in certain market areas.

NOTICE

See section 12.0 "Decal Identification and Location," item #7 for serial number location.

2.0 INTRODUCTION

The following is a quick reference to important procedures that must be followed while using the Vehicle Restraint System. It is not intended to cover, or suggest that it does cover, all procedures necessary to ensure safe operation. All operators should be aware of and abide by all workplace safety regulations applicable to the operation of the Vehicle Restraint System. These laws and regulations include but are not limited to:

- The Occupational Safety and Health Act
- Canada Occupational Health and Safety Regulations
- Occupational Safety and Health Acts for Individual States (USA)

For additional information on these regulations as well as industry standards that may apply to this product, please contact:

American National Standards Institute (ANSI)
 1430 Broadway
 New York, NY 10018
 Telephone: 212.642.4900
www.ansi.org



Also a member of:



Loading Dock Equipment Manufacturers
 A Product Section of Material Handling Industry of America
 A Division of Material Handling Industry
 8720 Red Oak Blvd, Suite 201
 Charlotte, NC, 28217-3992
 Telephone: 704.676.1190
www.mhi.org/lodem

2.1 WARRANTY INFORMATION

Thank you for purchasing Blue Giant products. We appreciate your business, and are confident that our product will serve you for many years to come. In the event that you experience a problem with our product, our Warranty Center is here to support the Blue Giant Product(s) that you have purchased.

To validate warranty on recently purchased equipment, please complete and submit your information with our on-line Warranty Registration at www.BlueGiant.com.

For more information about Blue Giant Warranty Support, please contact your local Blue Giant Equipment dealer, representative or authorized partner near you. You may also visit www.BlueGiant.com or phone 1.905.457.3900.

NOTE: All products must be registered to qualify for warranty.

DEALER INFORMATION

Name: _____

Contact: _____

Telephone: _____

2.2 EXCLUSION OF LIABILITY

The manufacturer assumes no liability for damage or injury to persons or property which occur as a result of defects or faults in or incorrect use of the Vehicle Restraint System. The manufacturer also assumes no liability for lost profits, operating downtimes, or similar indirect losses incurred by the purchaser. Injury to third parties, irrespective of its nature, is not subject to compensation.

The manufacturer reserves the right to make changes at any time to the modules, components, and accessories, concurrent with its continuing product improvements and development program. Specifications, operating instructions, and illustrations included in this manual are subject to change without notice. Please contact manufacturer for the latest information.

2.3 MANUFACTURER'S NOTE

The Vehicle Restraint has been carefully inspected and tested at the manufacturer's plant prior to shipment, but should be checked upon receipt for transport damage. Any observed transport damage is to be listed on the signed copy of the freight document. Notify the freight forwarder of any damage WITHIN 48 HOURS.

2.4 OWNER'S RESPONSIBILITY

1. The owner should recognize the inherent danger of the interface between the dock and the freight carrier. The owner should, therefore, train and instruct operators in the safe use of the dock equipment and accessories in accordance with the manufacturer's recommendations.
2. The owner should thoroughly familiarize themselves with the following procedures and specifications, and request immediate replacement of all manufacturer-supplied documents that are missing, damaged, or otherwise illegible. Below is a list of Best Practices for dock equipment usage and maintenance.
 - Commissioning instructions
 - Operating instructions
 - Daily maintenance procedures checklist
 - Inspections procedures
 - Recommended spare parts lists

Upon receipt of any newly purchased dock equipment, the owner shall verify the presence of owner's manuals, operating placards, and any other documentation necessary for training dock personnel how to use the equipment safely and effectively.
3. All Blue Giant dock equipment should undergo regularly scheduled planned maintenance. Maintenance requirements will vary according to usage frequency and application, so the owner shall consult with their authorized Blue Giant distributor for schedule recommendation. Written records of the performance of these procedures should be kept as per warranty requirements.
4. Dock equipment that is structurally damaged, experiencing performance irregularities, or has been potentially compromised shall be removed from service until a trained and authorized manufacturer's representative can conduct an inspection and perform any necessary repairs.
5. As with any piece of machinery, dock equipment requires routine maintenance, lubrication, and adjustments. Recommended procedures are itemized in the Planned Maintenance Program (PMP) checklist included in installation and technical manuals. It is recommended that for anything other than the basic maintenance procedures outlined in this manual, you contact your local Blue Giant representative.
6. The owner shall ensure that all name plates and safety labels are in place and legible, and that the appropriate manuals are provided to authorized users. Replacement name plates, safety labels, and manuals are available through the Blue Giant Aftermarket Department. See "Decal Identification and Location" section in this manual for more information.
7. The owner or a trained and authorized representative shall verify that all freight carrier brakes have been applied and a vehicle restraint and/or wheel chocks properly engaged before cross-docking procedures begin. For safety reasons trailers must be held securely in place to avoid accidental separation from the loading dock.
8. Unless specifically agreed to in writing by Blue Giant Equipment Corporation at the time of order (and prior to manufacture), all Blue Giant Dock equipment is sold as a complete offering and must not be altered or added to in any manner (which includes configuration and function) without written permission from an authorized manufacturer's representative. These changes shall also satisfy all safety recommendations of the original equipment manufacturer for the particular application of the dock equipment.
9. If, at the request of the owner, Blue Giant does not supply all or some of the dock equipment power unit and/or control panel components, the owner shall assume responsibility for any and all operational and safety issues associated with the resulting configuration.

3.0 SAFETY MESSAGE COLOR IDENTIFICATION

This manual includes color-coded safety messages that clarify instructions and specify areas where potential hazard exists. To prevent the possibility of equipment damage and serious injury or death, please observe strictly the instructions and warnings contained in the messages. If warning decals become damaged or missing, replace them immediately. Avoid accidents by recognizing dangerous procedures or situations before they occur.

⚠ DANGER	NOTICE
Serious injury or death will likely occur if the instructions are not followed.	Procedures marked notice must be followed in order to prevent damage to machinery.
⚠ WARNING	⚠ CAUTION
Serious injury or death may occur if the instructions are not followed.	Instructions marked caution concern safe operating procedure. Failure to comply may result in personal injury.

3.1 OPERATIONAL SAFETY WARNINGS

⚠ DANGER	
<p>Keep hands and feet away from operating space of the restraint apparatus.</p> <p>CRUSH HAZARD</p> 	<ol style="list-style-type: none"> 1. Do not operate the dock equipment while anyone is standing in its path. 2. Lift the dock equipment with suitable hoisting equipment only. Do not stand under the dock equipment or any heavy object while it is being hoisted. 3. BEFORE BEGINNING ANY SERVICE PROCEDURES: Disconnect the power and follow all lockout / tagout procedures outlined in this manual.
⚠ WARNING	
<ol style="list-style-type: none"> 1. Installation must be performed only by trained and authorized personnel. 2. Prior to installation, place adequate barriers to prevent vehicle traffic from entering the work area. 3. During installation, anchors must be properly torqued to achieve the necessary anchoring strength. DO NOT USE IMPACT DRIVERS. 4. Any electrical work must be performed by qualified personnel only. 5. Do not remove the wheel chocks until loading /unloading is finished and the truck is cleared for departure or the vehicle restraint has been released and the lights have changed to RED inside and GREEN outside. 	
NOTICE	
<ol style="list-style-type: none"> 1. Do not ground welding equipment to any electrical components. 2. Do not allow the drill to go too deeply into the control box, as damage may occur to the control systems. 3. Never use air to blow debris from the control box. Use a vacuum to perform any necessary cleaning. 4. Do not connect green ground lead into control box or junction box until all welding has been completed. 5. If an extension plate / box is required, securely mount it on the restraint with hardware provided before shimming and drilling. 6. Improper adjustments and / or lubrication may cause operational problems with equipment. 7. Check hydraulic fluid level. 8. Do not force the valve adjustment screws against the internal stops. 	
⚠ CAUTION	
<ol style="list-style-type: none"> 1. Only trained personnel should operate or service this equipment. 2. Do not operate the dock equipment until the transport vehicle is parked against the dock bumpers. 3. Always park the dock equipment after use (ensure that the lip is safely parked in the lip keepers). 4. Conduct routine inspections and maintenance. Failure to do so could cause equipment damage and or personal injury. 5. Always call your authorized service representative or manufacturer immediately if a malfunction occurs. 6. Always return the restraint arm to the parked position after use. 	

4.0 LOCKOUT / TAGOUT PROCEDURE AND RULES

In accordance with the rules and regulations of the Occupational Safety and Health Administration (OSHA), all affected employees must be notified that the machine or equipment will be shut down and locked out to perform repair or maintenance work. The work area must be checked to ensure that all personnel have been removed or safely repositioned. The machine or equipment power supply shall be locked in the OFF position or disconnected from the energy source. Blue Giant strongly recommends that only OSHA-approved lockout devices and procedures be utilized.

The energy isolating device must bear a prominent warning tag indicating that work is being done on the equipment and the name of the authorized employee responsible for the lockout. It is mandatory that tagout notices not be susceptible to deterioration or illegibility due to weather conditions or exposure to chemicals and moisture.

WARNING

Always lockout and tagout any power source before performing any work on any electrical devices or electrical controls according to OSHA regulations and approved local electrical codes.

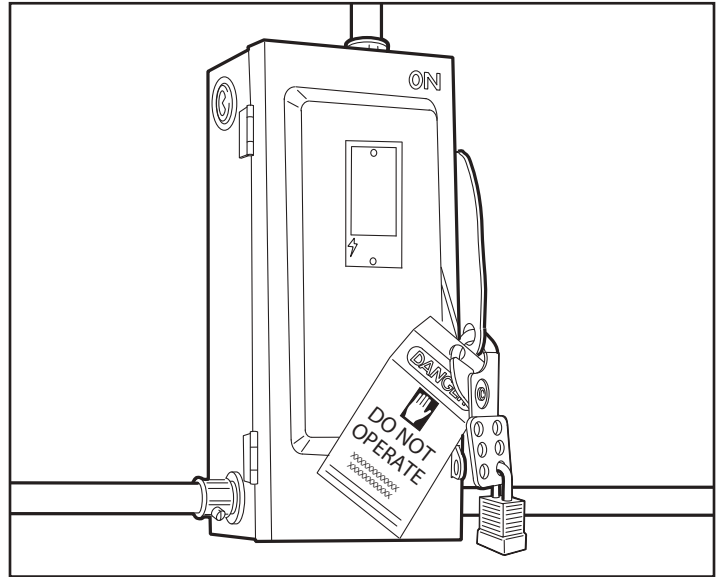

Approved way to lockout / tagout.

5.0 EMERGENCY VEHICLE RESTRAINT LOWERING PROCEDURE

CAUTION

Turn off power switch/disconnect before performing manual emergency release procedure, as power may initiate without warning.
Ensure that traffic lights will not be operating and that the trailer is secure.

Should a power failure or equipment malfunction occur while the restraint arm is in the locked position, the locking mechanism can be released manually. The restraint arm can then be lowered to the stored position.

Remove the cap from the manual release valve and turn the stem counterclockwise to open the valve and release the restraint arm. After the arm is safely stored, turn the stem clockwise until snug and replace the cap on the manual release valve. Normal operation may safely resume once the valve has been properly closed.

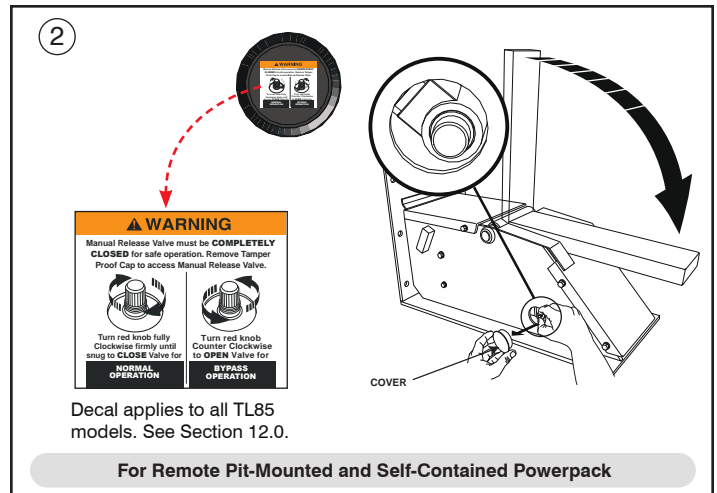
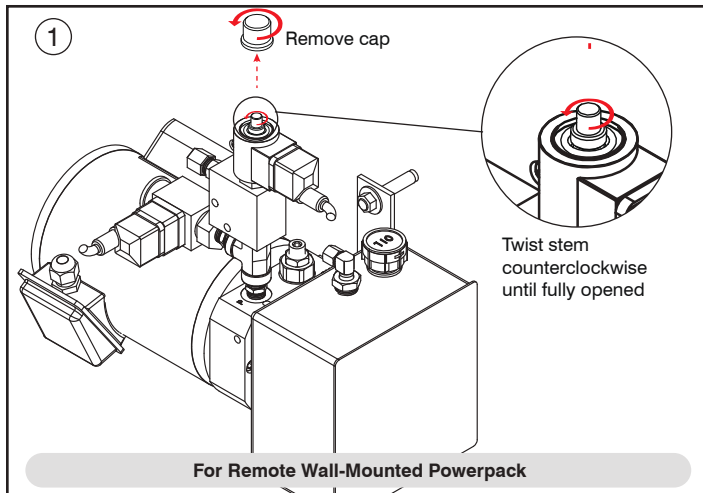

6.0 CONTROL PANEL OPERATION

Controls combinations of all supported dock equipment: one individual vehicle restraint, one individual dock leveler, and controls for a door. Also equipped with touch buttons, inside forklift operator traffic lights, operator menu screen, and keypad for coded features.

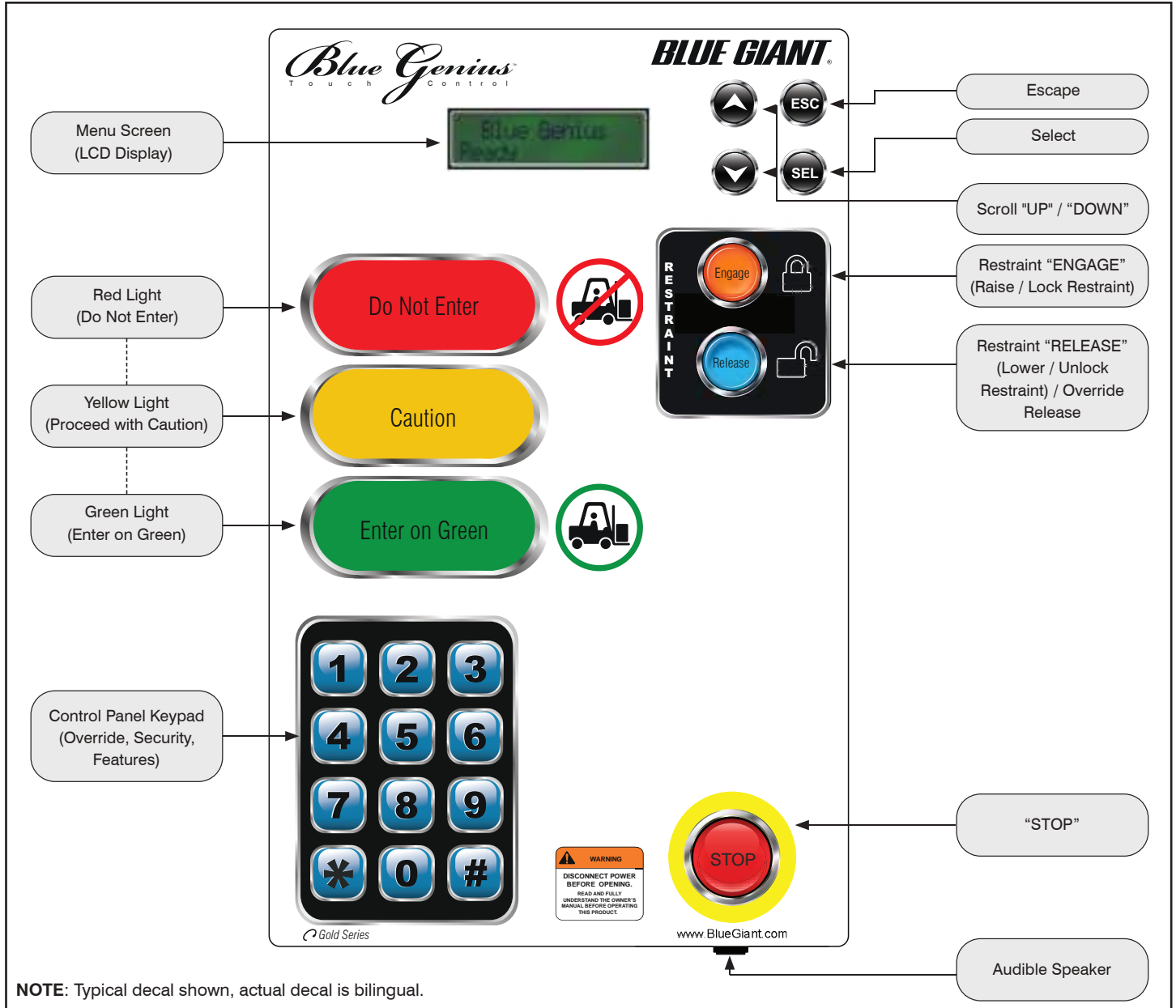

6.1 BUTTON FUNCTION

When touching any of the function buttons or keypad, use the pad of the finger. The control panel's unique touch sensors detect the proximity of the dock operator's finger. Audible touch buttons and keypad on the control panel provide instant sound feedback to user input.

The 'Engage' and 'Release' buttons require only a single touch or tap to activate their respective functions. Do not apply constant pressure.

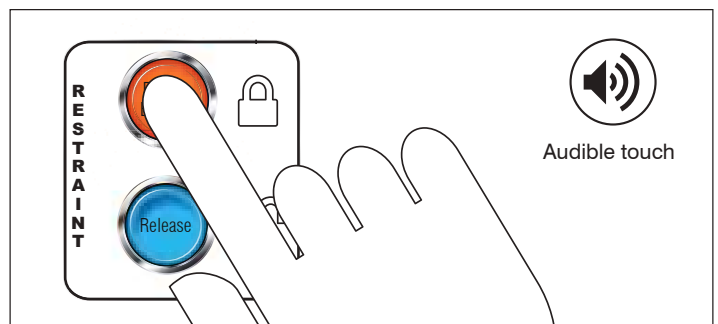

7.0 OPERATING INSTRUCTIONS

WARNING

Do not operate this vehicle restraint unless you have been trained and authorized to do so, and have read and understood all of the safety information and instructions contained in this manual.

Do not operate this restraint until you have checked its condition. Report the need for repairs to your supervisor immediately and do not operate the unit until repairs are made.

Never try to lift or move any part of the vehicle restraint manually. Keep hands and feet clear of vehicle restraint pinch points.

It is the responsibility of the owner / operator of truck / vehicle to (whenever possible) exhaust the air from air-ride suspension systems prior to performing loading or unloading. Because ICC bars differ in strength and construction, review the need to use wheel chocks in conjunction with the vehicle restraint.

This vehicle restraint is designed for rear impact guards (RIG) and rear impact protection (ICC Bar) that follow the Federal Motor Carrier Safety Administration guidelines (FMCSA section 571.223 and 571.224) + NHTSA (National Highway Traffic Safety Administration) guidelines.

OPERATING INSTRUCTIONS
Only for the StrongArm™ TL85 Vehicle Restraint

A ENGAGE RESTRAINT

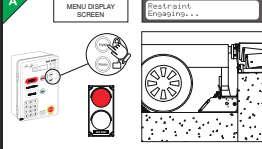

- Open the overhead door and confirm that the vehicle has an ICC bar and that it is aligned and in range of the restraint arm. The control panel light is RED and the traffic light is GREEN.
- Touch the 'Engage' button. The arm will rotate from the home position to secure the ICC bar and the LCD screen will read 'Restraint Engaging'. The traffic light will turn RED and the control panel light will remain RED. When the ICC bar is secured, the LCD screen will read 'Restraint is Engaged', followed by 'Dock Leveler Restored' and 'Ready to Raise Deck'. After the deck is deployed onto the truck bed, the control panel light will turn GREEN.

B DISENGAGE RESTRAINT

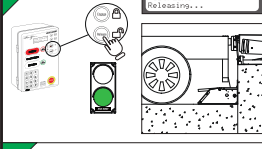

- After the dock leveler is safely parked, touch the 'Release' button to disengage the vehicle restraint. The control panel light will change to RED and the LCD screen will read 'Restraint Releasing'. When the arm reaches the home position, the LCD screen will read 'Blue Genius Ready' and the traffic light will turn GREEN.

NOTE: If the restraint arm was not properly parked, the LCD screen will read 'Arm Blocked'. Consult the Troubleshooting section of the manual.

C VEHICLE RESTRAINT OVERRIDE

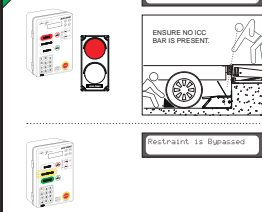

- Touch the 'Engage' button. If a vehicle's ICC bar is absent or cannot be engaged, the LCD screen will read 'ICC Bar Not in Range'. Determine whether the vehicle needs to be realigned or if wheel chocks are necessary. The control panel light and traffic light are both RED.
- Press the * key on the keypad. The LCD screen will read 'Enter Code *...'. Enter the supervisor code (Please call your Blue Giant distributor for further information). The LCD screen will read 'Dock Leveler Restored' and then 'Ready to Deploy Deck', followed by 'Restraint is Bypassed'. Once the deck is deployed and home sensor becomes inactive, the control panel will turn GREEN while flashing YELLOW, indicating to proceed with caution.
- Store the dock leveler. Touch the 'Release' button on the control panel. The control panel light will turn RED. The outside traffic light will turn GREEN, advising the truck driver that it is safe to depart once the wheel chocks are removed.

D STOP PROCEDURE



- Touching the 'STOP' button during operation will cut power to the restraint. If the arm is in mid-travel, it will lower to a hard stop via gravity. To exit the 'STOP' mode touch 'ESC'.

BLUE GIANT www.BlueGiant.com 038-766E Rev 1.1

TL85 operation placard, provided with equipment—part # 038-766E.

7.1 FUNCTIONAL DESCRIPTION

The vehicle restraint is used to restrain a trailer at the loading dock. When engaged, it secures a vehicle's under ride guard (ICC bar), restricting forward movement caused by vehicle creep or unscheduled departure. It is electric-hydraulic operated and monitored via the Blue Genius™ Touch Control Panel, and comes standard with an automatic lights communication package consisting of red / yellow / green control station lights and exterior red / green LED traffic lights.

EXTERIOR TRAFFIC LIGHT

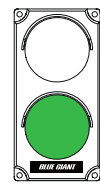

Exterior red / green traffic lights advise the truck driver when it is safe to depart.

INSIDE COMMUNICATION LIGHTS & CONTROL PANEL



Red / yellow / green control panel lights keep forklift operators and warehouse personnel advised of safety conditions at the loading dock.

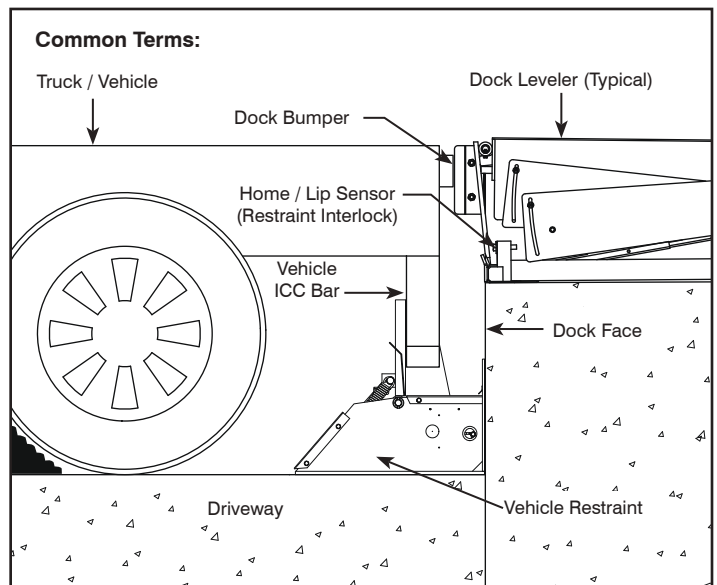

ADVANCED SAFETY FEATURES

7.2 STOP BUTTON FUNCTION

Should an unexpected interference occur or potentially dangerous situation arise, the Blue Genius™ control panel has a temporary 'STOP' button. Touching the 'STOP' button during operation will cause the unit to stop in mid motion and the audible alarm sound. To exit the 'STOP' mode touch 'ESC'.

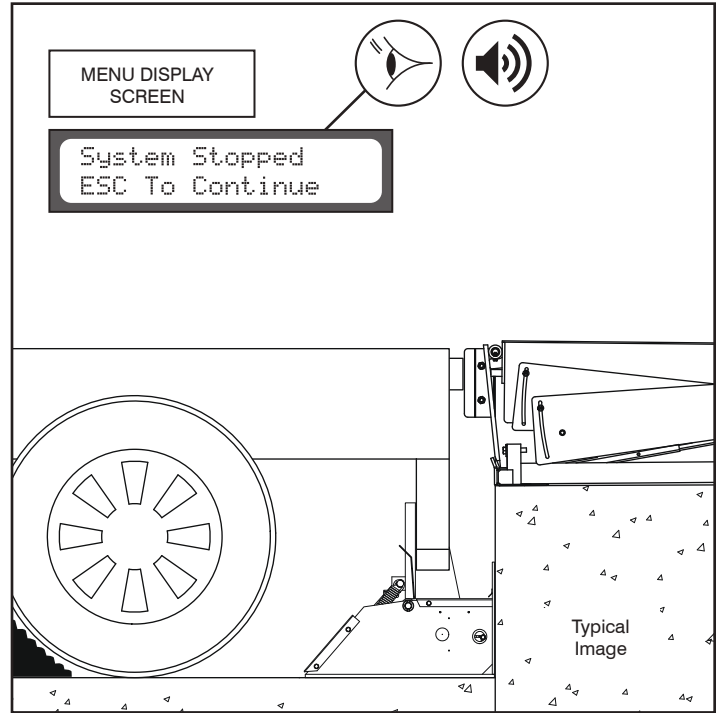
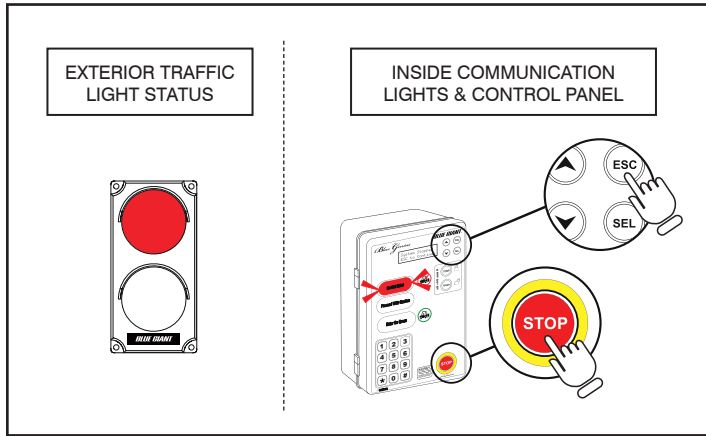

STANDARD OPERATION PROCEDURES

7.3 PRIOR TO USE: EQUIPMENT IN STORED POSITION

The Blue Genius™ control panel is powered on and ready for use. The restraint apparatus is in the home position and the dock leveler lip is parked safely in the lip keepers. The exterior traffic light is GREEN and the control panel light is RED.

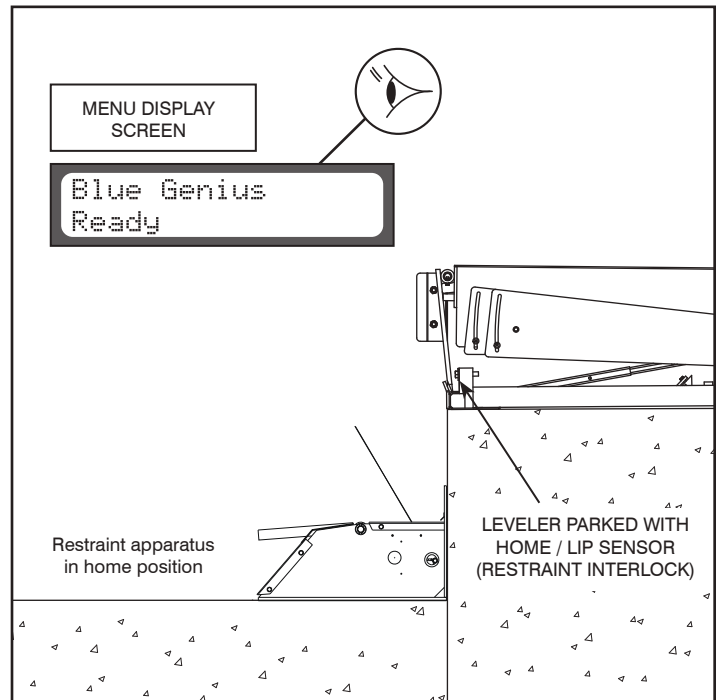
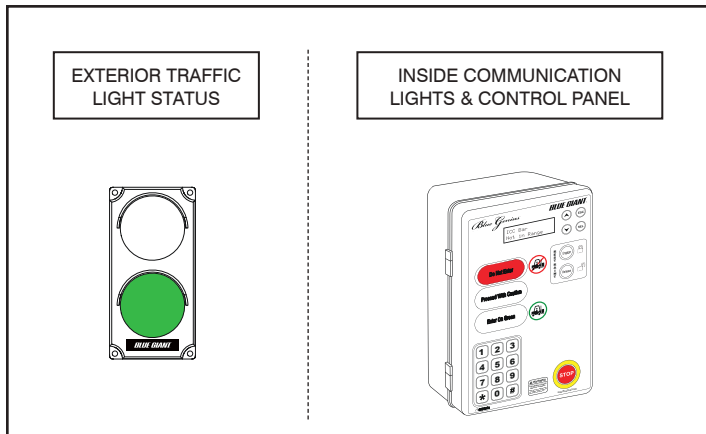

7.4 TRAILER AT BAY

The truck reverses into position against the dock leveler bumpers. The exterior traffic light is GREEN and the control panel light is RED.

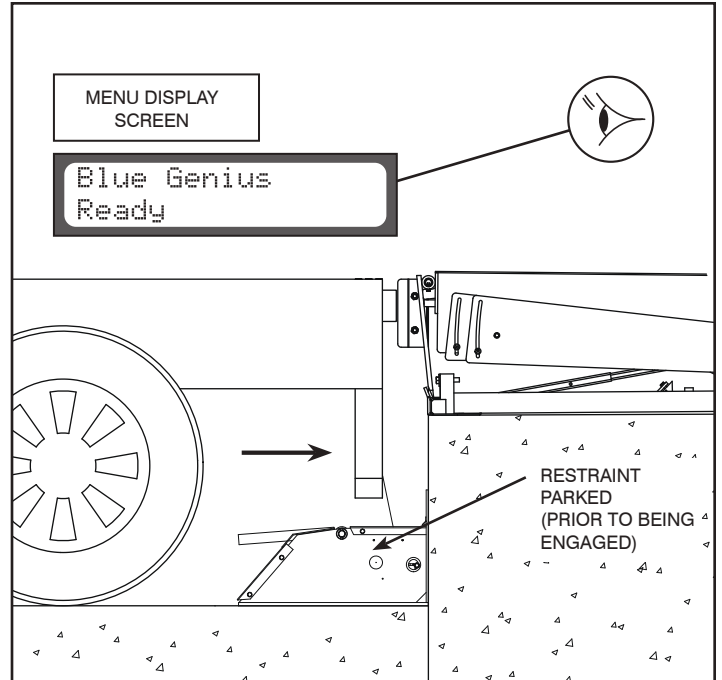
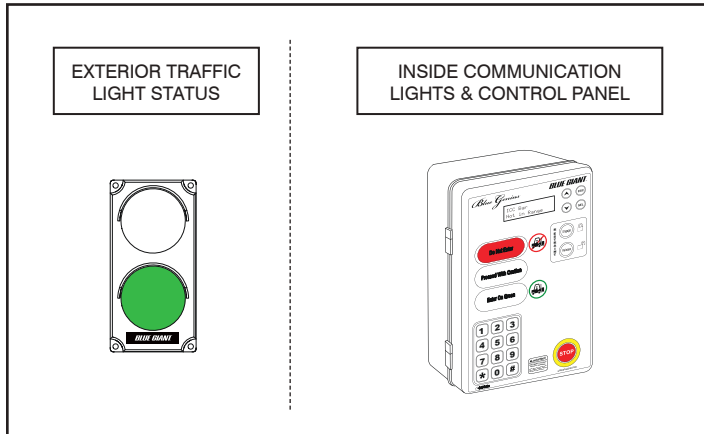

7.5 ENGAGING RESTRAINT

Touch the 'Engage' button on the control panel. The securing apparatus will exit the stored position to secure the truck's ICC bar. The exterior traffic light will turn RED and the control panel light will remain RED. The LCD screen will read 'Engaging' When the ICC bar is secured, the LCD screen will read 'Restraint is Engaged', followed by 'Dock Leveler Restored' and 'Ready to Raise Deck'. The exterior traffic light remains RED, warning the truck driver to stay in place.

NOTE: For vehicles without an ICC bar, or if the restraint apparatus cannot successfully engage, see Section 8.0 "Engaging the Override Feature" for more information.

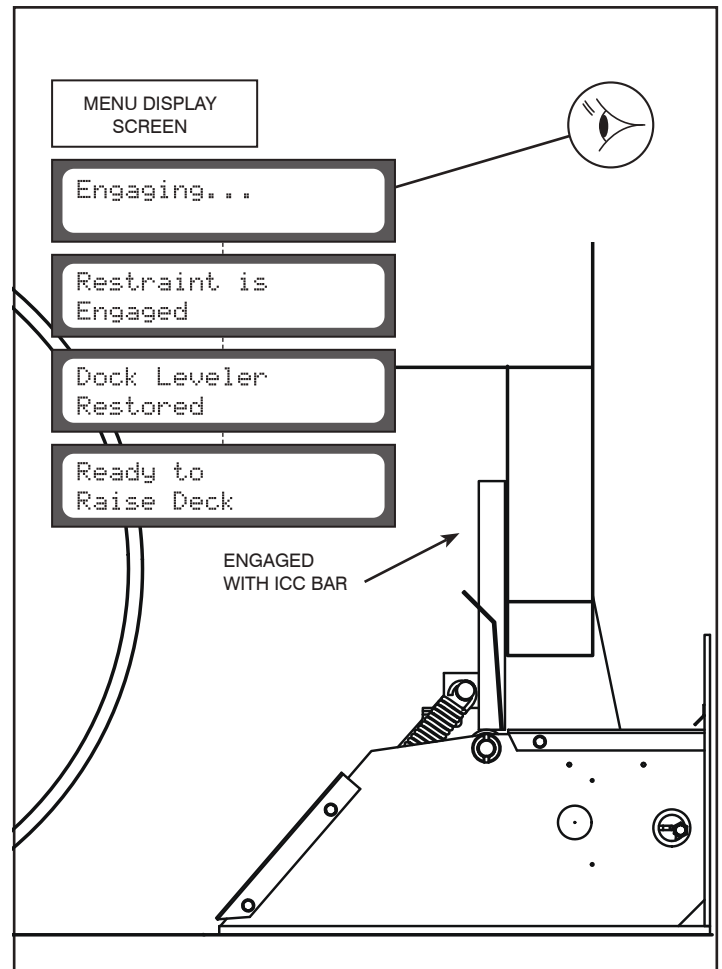
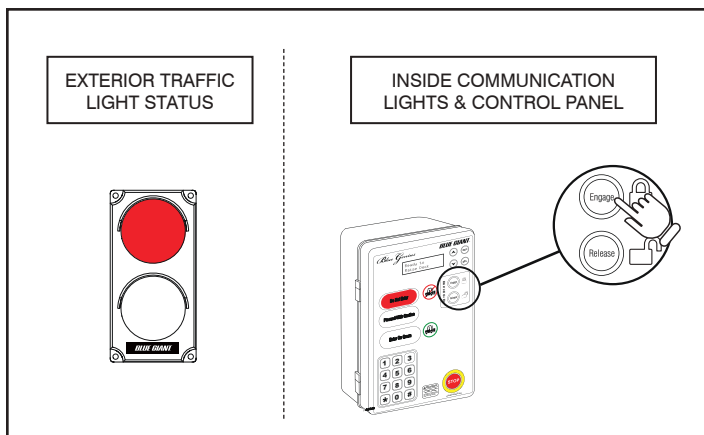

7.6 DEPLOYING THE DOCK LEVELER

Deploy the dock leveler (supplied by others) using controls provided by original manufacturer. Both the exterior traffic light and the control panel light will be RED. When the deck rises, the LCD screen will read 'Deck Moving'. The dock leveler and deployed lip will descend onto the truck bed and the message will now read 'Deck Deployed'. The control panel light will turn GREEN.

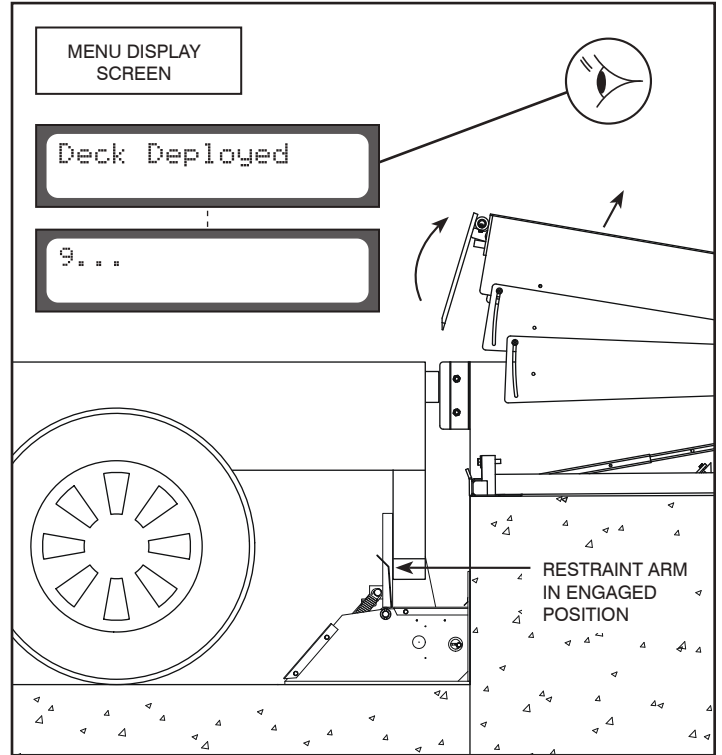
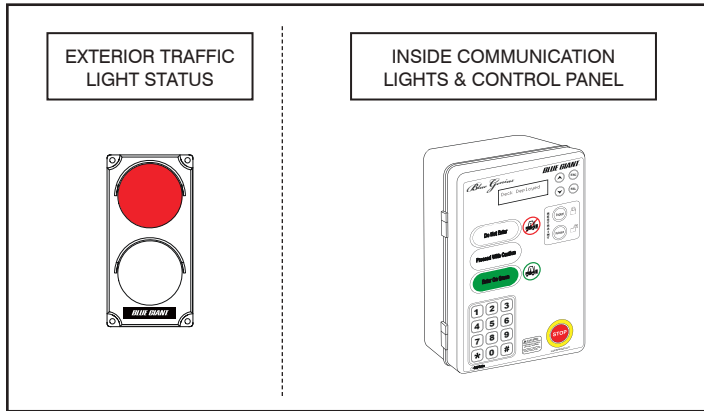

PERFORM LOADING AND UNLOADING

7.7 RELEASING THE RESTRAINT ARM

After the dock leveler is safely parked, the control station light will turn RED while the outside traffic light remains RED. Touch the 'Release' button to disengage the vehicle restraint. The LCD screen will read 'Restraint Releasing.' When the restraint arm reaches the home position, the LCD screen will read 'Blue Genius Ready' and the outside traffic light will turn GREEN.

NOTE: If the securing apparatus was not properly parked, the LCD screen will read 'Arm Blocked'. See Section 15.0 "Vehicle Restraint Troubleshooting" for more information.

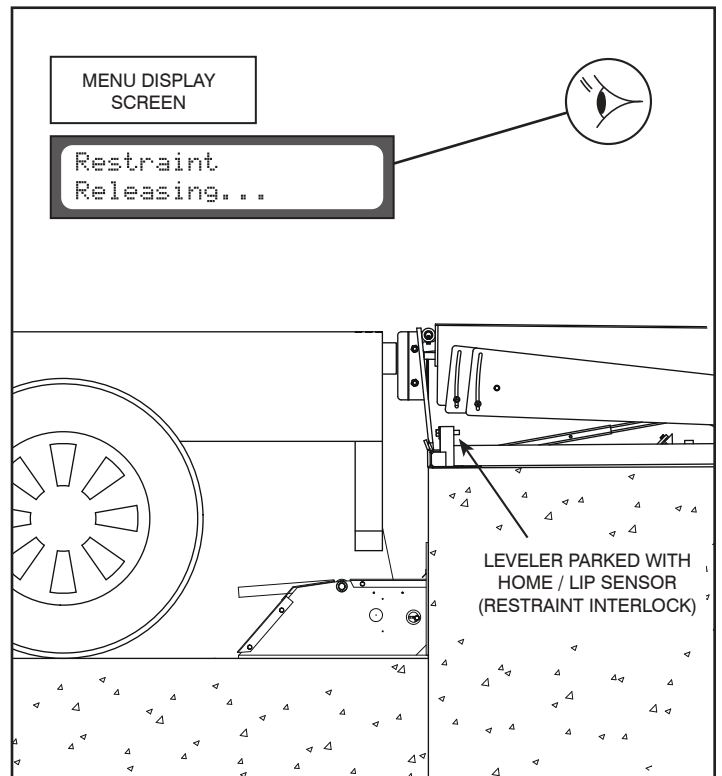
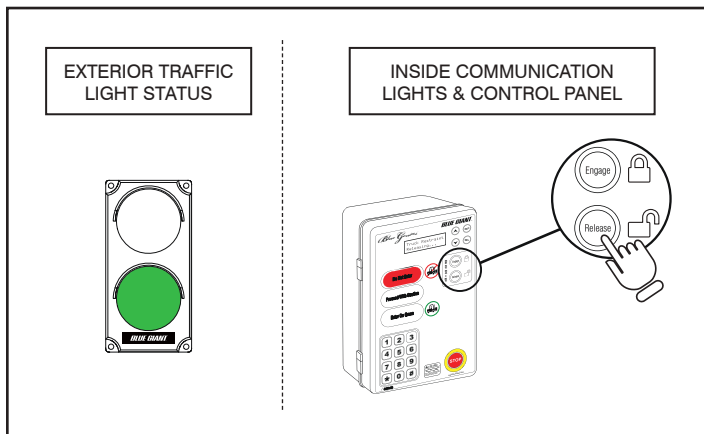

8.0 ENGAGING THE OVERRIDE FEATURE

Should it be necessary to bypass the vehicle restraint function (i.e. the truck has an outdated, damaged, or missing ICC bar), a system-approved override code may be entered via the Blue Genius™ touch keypad. This code can be used whether or not the dock leveler is interlocked with the Blue Genius.™ Ensure that the vehicle is manually chocked before loading and unloading begins.

NOTE: If a visual inspection confirms that the ICC bar is missing or too damaged to be secured then depending on your Blue Genius Software version:

- Up to Version 3.0 (inclusive), bypass Step 1 in the instructions below and go directly to Step 2, which explains how to enter the Override Code.
- From Version 3.1 and higher, step 1 is required sequence and then proceed to step 2, follow the instructions. Alternative sequence processes may be available, please consult your Blue Giant representative.

1. During "Engaging Restraint" (Section 7.5), the LCD screen may read "ICC Bar Not in Range." This message indicates that a vehicle's ICC bar is absent or cannot be engaged.

Determine whether the vehicle needs to be realigned or if wheel chocks are necessary.

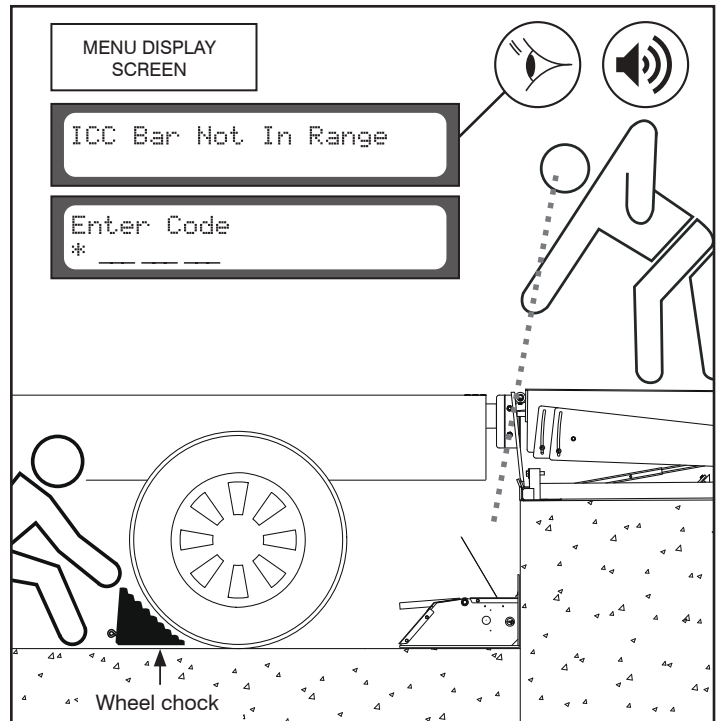

- 2A. Press the * key on the keypad. The LCD screen will read 'Enter Code * _ _ _ _'.

Enter the supervisor code (default factory set code is '247').

NOTE: The default code can be changed. Please call your Blue Giant representative for further information.

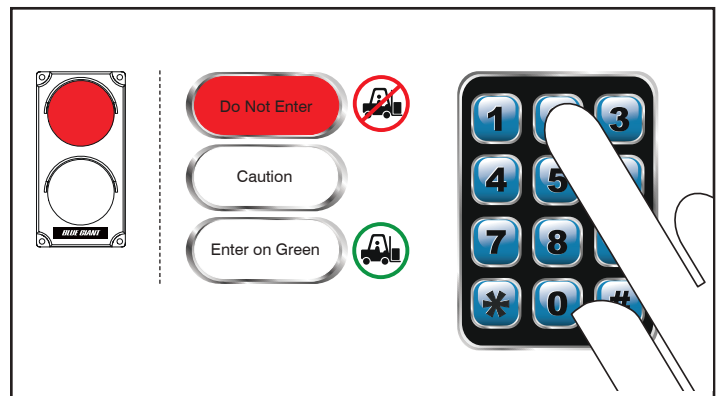

8.0 ENGAGING THE OVERRIDE FEATURE CONT'D.

Continue operation of overhead door, dock leveler, and vehicle restraint as outlined in Section 7.5 "Engaging Restraint". The following indicators will appear:

- 2B. The LCD screen will read 'Dock Leveler Restored' and then "Ready to Deploy Deck," followed by "Restraint is Bypassed."

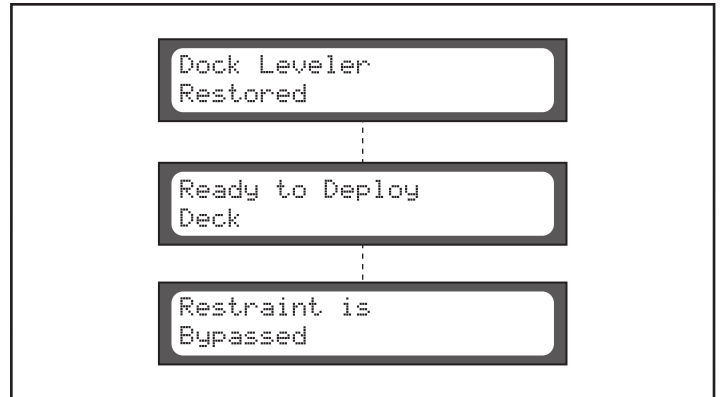

- 2C. Once the deck is deployed and the home/lip sensor becomes inactive, the control panel light will turn GREEN while flashing YELLOW. This indicates that the vehicle restraint is not engaged.

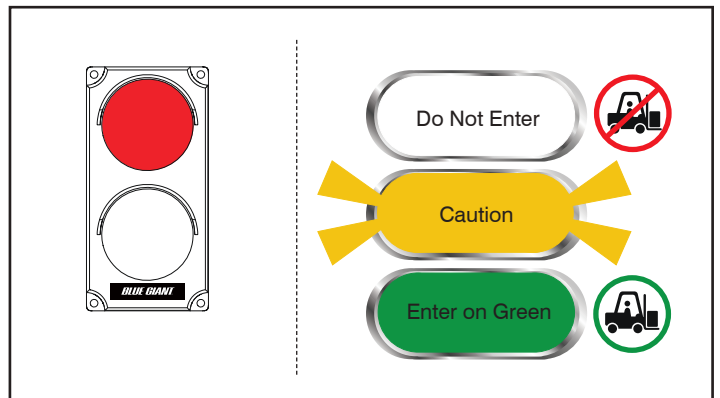

8.1 RELEASING THE OVERRIDE FEATURE

1. Store the dock leveler. (**NOTE:** Override is still active when dock leveler and vehicle restraint are in the parked position). The control panel light will turn RED.

Touch the 'Release' button on the control panel to release the override. The control panel will verify that the vehicle restraint has been lowered to the home position. The LCD screen will read "Blue Genius Ready."

The exterior traffic light will turn GREEN, advising the truck driver that it is safe to depart once the wheel chocks are removed.

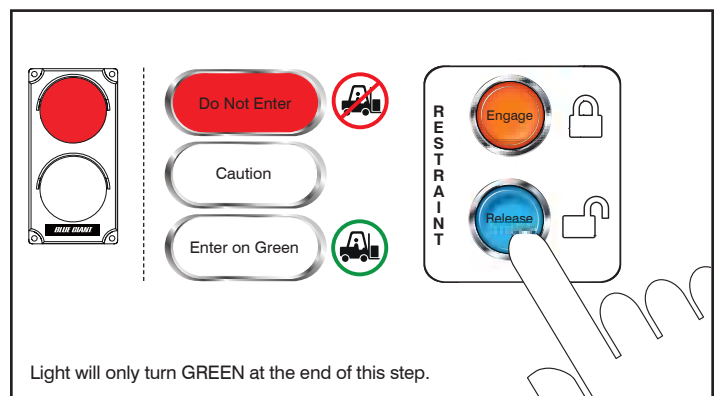

9.0 MAINTENANCE



WARNING

Do not operate and/or service this vehicle restraint until you have read and understood all of the safety information and instructions contained herein and on the vehicle restraint.

Do not work under or around the vehicle restraint without first placing adequate barriers to positively prevent vehicle traffic from entering the work area.

Follow proper lock-out/tag-out procedures.

Keep hands and feet clear of vehicle restraint pinch points and wear appropriate safety attire – glasses, gloves and work boots.

9.1 PLANNED MAINTENANCE PROGRAM (PMP)

In addition to the Daily Maintenance Procedures (DMP), the manufacturer recommends (and local government regulations may require) that a planned maintenance program (PMP) and safety inspection program be performed by a trained and authorized service technician on a regular basis to ensure the equipment is in safe operating condition. The PMP will provide an opportunity to make a thorough inspection of the safety and operating condition of the dock leveler. Necessary adjustments and repairs can be done during the PMP, which will increase the life of components and reduce unscheduled downtime.

Recommended procedures for a periodic planned maintenance program that covers inspections, operational checks, cleaning, lubrication, and minor adjustments are outlined in the Installation and Technical manual for this product.

An authorized dealer or distributor is prepared to assist with a planned maintenance program by offering trained service personnel with expertise in dock leveler maintenance requirements.

9.2 OPERATOR DAILY INSPECTION

The vehicle restraint should always be examined by the operator PRIOR TO ANY USE to verify that it is safe to operate.

The manufacturer recommends making multiple photocopies of the DMP Checklist (See Section 9.7). The operator should fill out this form to keep a daily record of operation and maintenance issues.

9.3 ROUTINE SERVICING AND MAINTENANCE

Regular maintenance and care of the vehicle restraint is very important for cost, operation efficiency, and operator safety. A faulty vehicle restraint is a potential source of danger to the operator, and to other personnel working near it. As with all quality equipment, keep the vehicle restraint in good operating condition by following

the recommended schedule of maintenance.

Failure to properly maintain or operate the dock leveler within its rated capacity can void the manufacturer warranty.

9.4 PLANNED MAINTENANCE PROGRAM INTERVALS

Arrange for a qualified vehicle restraint service technician to perform regularly scheduled planned maintenance on your vehicle restraint every three months for single shift operations or monthly for multi-shift operations. Call your authorized manufacturer or dealer for further details.

9.5 MAINTENANCE SEQUENCE

1. Cleaning, including pit area
2. Visual inspection of all components
3. Lubrication, as required (by a trained service technician only)
4. Test operate all functions
5. Adjustments, if required (by a trained service technician only)
6. Check for missing or damaged dock bumpers
7. Record inspection details and findings for owners' files

9.6 RECOMMENDED HYDRAULIC FLUIDS

The unit is shipped with Petro-Canada Hydrex MV22 hydraulic oil unless otherwise optioned.

Normal, All Season Weather Conditions:

Valvoline All Weather 36 or equivalent.

NOTE: Dextron II Automatic Transmission Fluid may be used if other suitable oils are not available.

Extreme Low Temperature Conditions:

Esso Unis N15 or Gulf Harmony Arctic 15 or suitable equivalent.

Biodegradable: Esso Unis Bio 40 or suitable equivalent.

9.7 DAILY MAINTENANCE PROCEDURES CHECKLIST - STRONGARM™ TL85 VEHICLE RESTRAINT

INSPECTED BY: _____ DATE: _____

SERIAL #: _____ DOOR #: _____

Forward this checklist to the person responsible for dock equipment maintenance. See Section 1.1 "Owner's Purchase Record" for Date in Service.

INSTRUCTIONS FOR USE: Indicate "OK for USE" with a check mark ✓ in the appropriate box of each inspection point.

EVERY DAY (MAY BE PERFORMED BY OWNER OR ATTENDANT):

- Remove any debris that may have accumulated around the dock equipment
- Verify complication-free operation of the dock equipment and the interior and exterior lights system
- Verify that outside signage is present and legible
- Verify complication-free operation of the Blue Genius™ Control Panel
- Verify that dock bumpers are secure
- Check for hydraulic leaks
- Verify pivot-free operation of wand
- Check concrete where unit is mounted for cracks or signs of instability
- Verify that instructional caution and danger labels are present and legible on the product. Replace if necessary

SCAN/PHOTOCOPY THIS CHECKLIST AND FILL OUT REGULARLY FOR YOUR RECORDS.

Explain faults briefly in the space provided below:

DANGER

When repairing or conducting maintenance procedures on electrical components, perform lockout / tagout steps according to OSHA regulations and approved electrical codes.

DANGER

Prior to installation, place adequate barriers to prevent unauthorized personnel and vehicle traffic from entering the work area.

WARNING

All repairs and maintenance work are to be conducted by trained and authorized personnel ONLY.

10.0 POWERPACK CONFIGURATIONS

The TL85 is available in three different powerpack configurations: Remote Wall-Mounted (W), Remote Pit-Mounted (P) and Self-Contained (S).

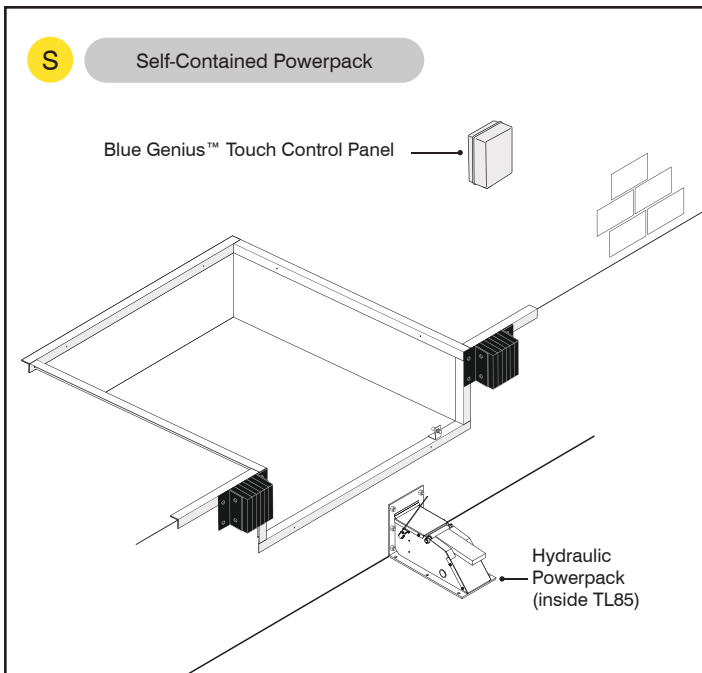
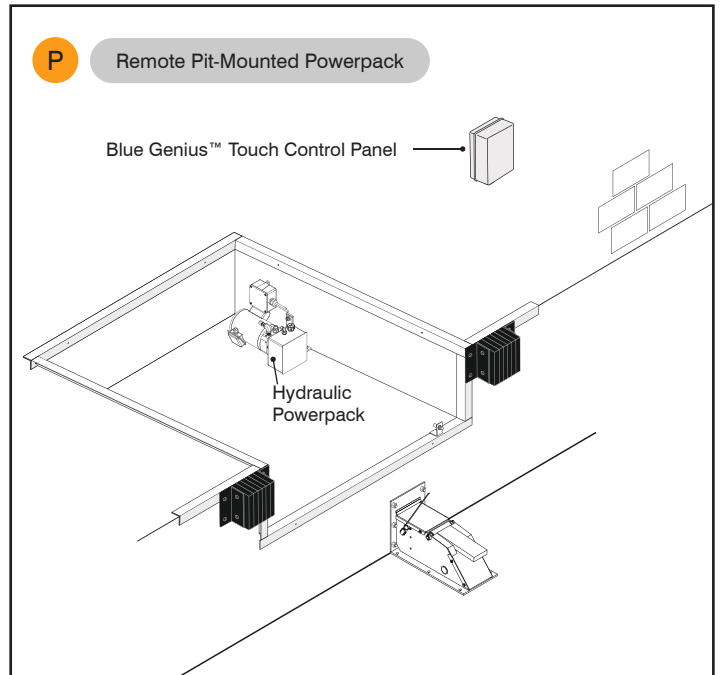
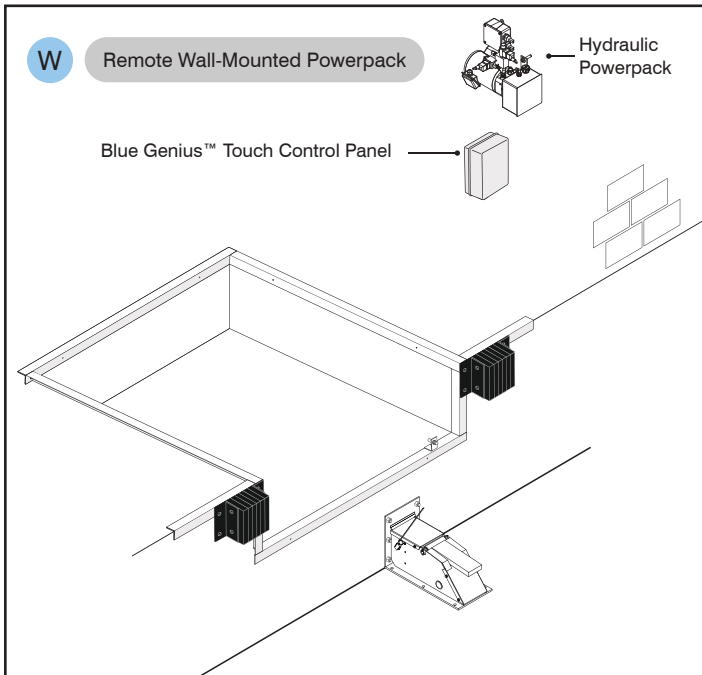

LEGEND	
W	Section or item applies only to Remote Wall-Mounted Powerpack.
P	Section or item applies only to Remote Pit-Mounted Powerpack.
S	Section or item applies only to Self-Contained Powerpack.



11.0 RECOMMENDED SPARE PARTS

11.1 STANDARD OPERATIONAL COMPONENTS

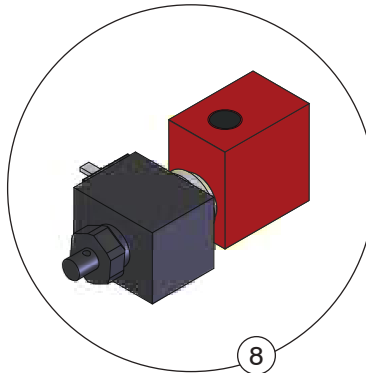
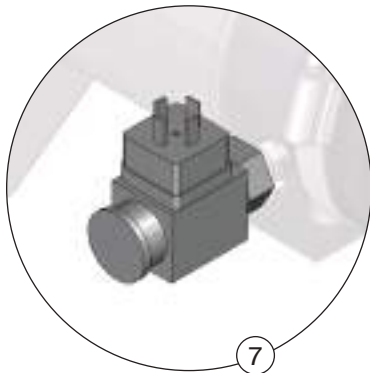
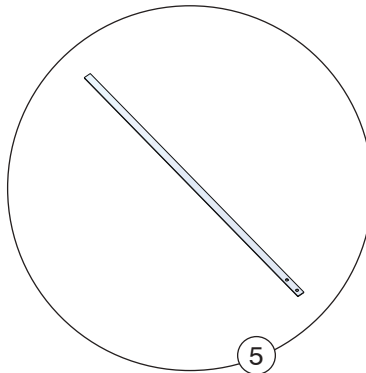
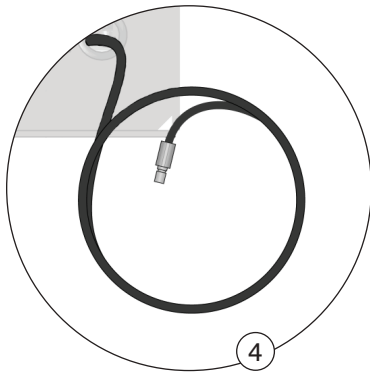
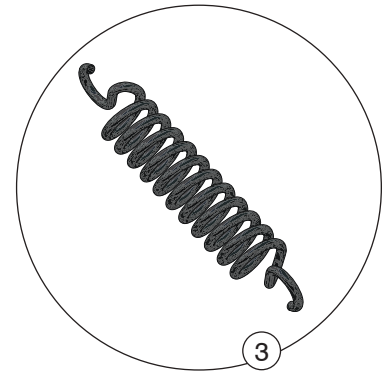
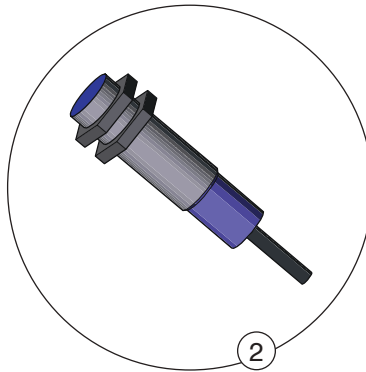
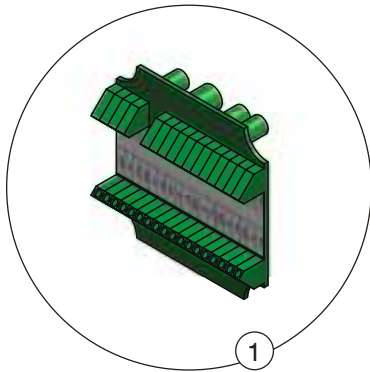

RSP FOR TL85 – STANDARD OPERATIONAL COMPONENTS			
ITEM	PART NO.	DESCRIPTION	QTY REQ'D
1	026-G025M	Remote I/O Board (Resistor)	1
2	028-200	Proximity Sensor, 18 mm	1
3	017-085	Extension Spring, Wand Return	1
4	100-5000-41	Hose Assembly #4 high pressure 22' (6.7m) W	1
	100-5000-40	Hose Assembly #4 high pressure 14' (4.3m) P	
	100-5000-5	Hose Assembly #4 high pressure 20" (.5m) S	

RSP FOR TL85 – STANDARD OPERATIONAL COMPONENTS			
ITEM	PART NO.	DESCRIPTION	QTY REQ'D
5	51-013611	Sensor Wand	1
6	035-662	Cylinder Assembly	1
7	035-293-A	Pressure Switch	1
8	033-508-24-K	Solenoid Valve, Arm Lock Valve with Manual Release	1
9*	026-G074	Solenoid Valve Connector with Cable	1

* Optional



11.2 COMPONENT SHIELDS

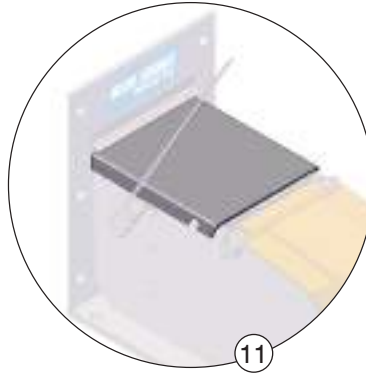

RSP FOR TL85 – COMPONENT SHIELDS

ITEM	PART NO.	DESCRIPTION	QTY REQ'D
10	115-100	Front Cover	1
	115-100-ZP	Front Cover, Zinc Plated	
11	115-103	Top Cover	1
	115-103-ZP	Top Cover, Zinc Plated	



12.0 DECAL IDENTIFICATION AND LOCATION

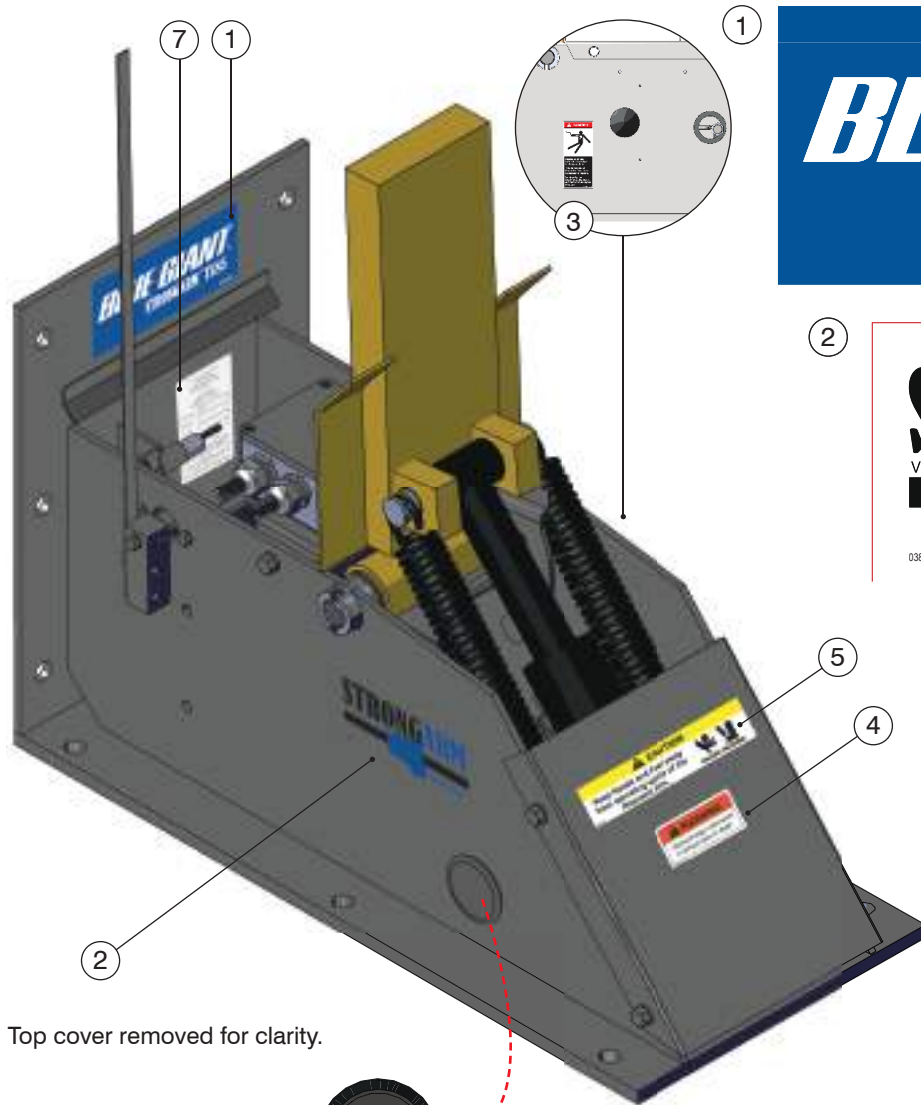

Top cover removed for clarity.



Inside of plug button shown.



ITEM	QTY	PART NO.	DESCRIPTION
1	1	038-863	Decal - BG StrongArm™ TL85
2	2	038-1187E	Decal - StrongArm™ - Vehicle Restraint
3	1	038-084EFS	Warning Decal - Hazardous Voltage
4	1	038-048-2	Warning Decal - Spring Energy
5	1	038-243E	Decal- Crush Hazard
6	1	038-057	Decal - Manual Release Valve
7	1	038-299EF	Decal - Serial Plate - English / French
		038-299ES	Decal - Serial Plate - English / Spanish

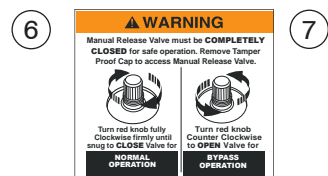

BLUE GIANT EQUIPMENT CORPORATION
85 Heart Lake Road South
Brampton, Ontario, Canada
L6W 3K2

www.BlueGiant.com
MADE IN CANADA
FABRIQUE AU CANADA

MODEL/ NO. DE MODELE: TL85

SERIAL NO./ NO. DE SERIE: _____

ANSI CODE: _____

CONST. MM / YYYY: _____

TEST LOAD/ TEST DE CHARGE: _____ lbs. / _____ kg.

"REFER TO SAFETY AND OPERATING INSTRUCTIONS IN YOUR OWNERS MANUAL" / "VOIR LES CONSIGNES DE SECURITE ET LE MODE D'EMPLOI DANS VOTRE GUIDE D'UTILISATION."

038-299EF



13.0 EQUIPMENT COMPONENT ILLUSTRATIONS

13.1 COMPONENTS AS SHIPPED CHECKLIST

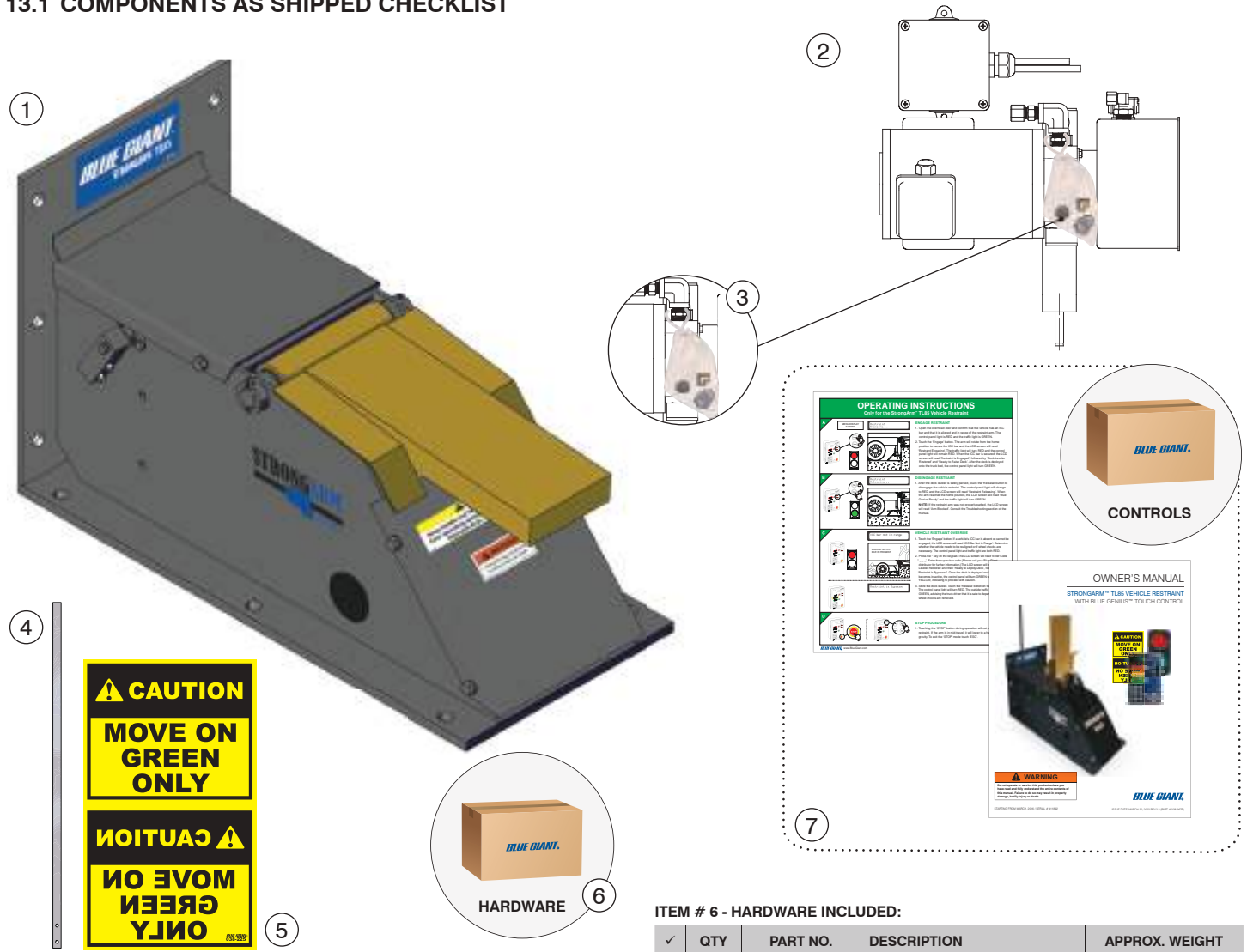

✓	ITEM	QTY	PART NO.	DESCRIPTION	APPROX. WEIGHT		
	1	1	51-013732	TL85 Body	200 lb	91 kg	
			51-013732-ZP	TL85 Body, Zinc Plated			
	2	1	51-012895_	Powerpack (See Section 13.5, 13.6, or 14+.1, for voltages, depending on configuration)	34 lb	15 kg	
			51-009410_				
			033-697				
	3	1	107-873	Bag of Hardware for Powerpack		N/A	N/A
				034-726	Reducer Bushing		
				040-007	90 DEG Breather Tube Fitting		
				021-331	Breather Plug		
	4	1	51-013611	Sensor Wand	.15 lb	.07 kg	
	5	1	038-225	E	Exterior Driver Warning Sign (English / French / Spanish)	.7 lb	.3 kg
				F			
				S			

ITEM # 6 - HARDWARE INCLUDED:

✓	QTY	PART NO.	DESCRIPTION	APPROX. WEIGHT	
	6	010-108	5/8" x 6" (16 x 152 mm) Expansion Anchors	.225 lb	.1 kg

ITEM # 7 - CONTROL AND COMPONENTS INCLUDED:

✓	QTY	PART NO.	DESCRIPTION	APPROX. WEIGHT	
	1	BGG0T_F See Sec. 13.7	Complete Control Assembly English / French	6.2 lb	2.8 kg
		BGG0T_S See Sec. 13.7	Complete Control Assembly English / Spanish		
	1	032-806	Exterior Traffic Light	1.3 lb	0.6 kg
	1	038-766E	Operation Placard	—	—
	1	038-967E	TL85 Owner's Manual	—	—
	1	038-707EI	TL85 Installation Manual	—	—
	1	038-967EPL	TL85 Parts List	—	—
Restraint Interlock:					
	1	028-206	Lip Sensor	.4 lb	.19 kg
	1	21-002154	Mounting Bracket		

W

13.2 MECHANICAL ASSEMBLY - 51-013732 AND 51-013732-ZP

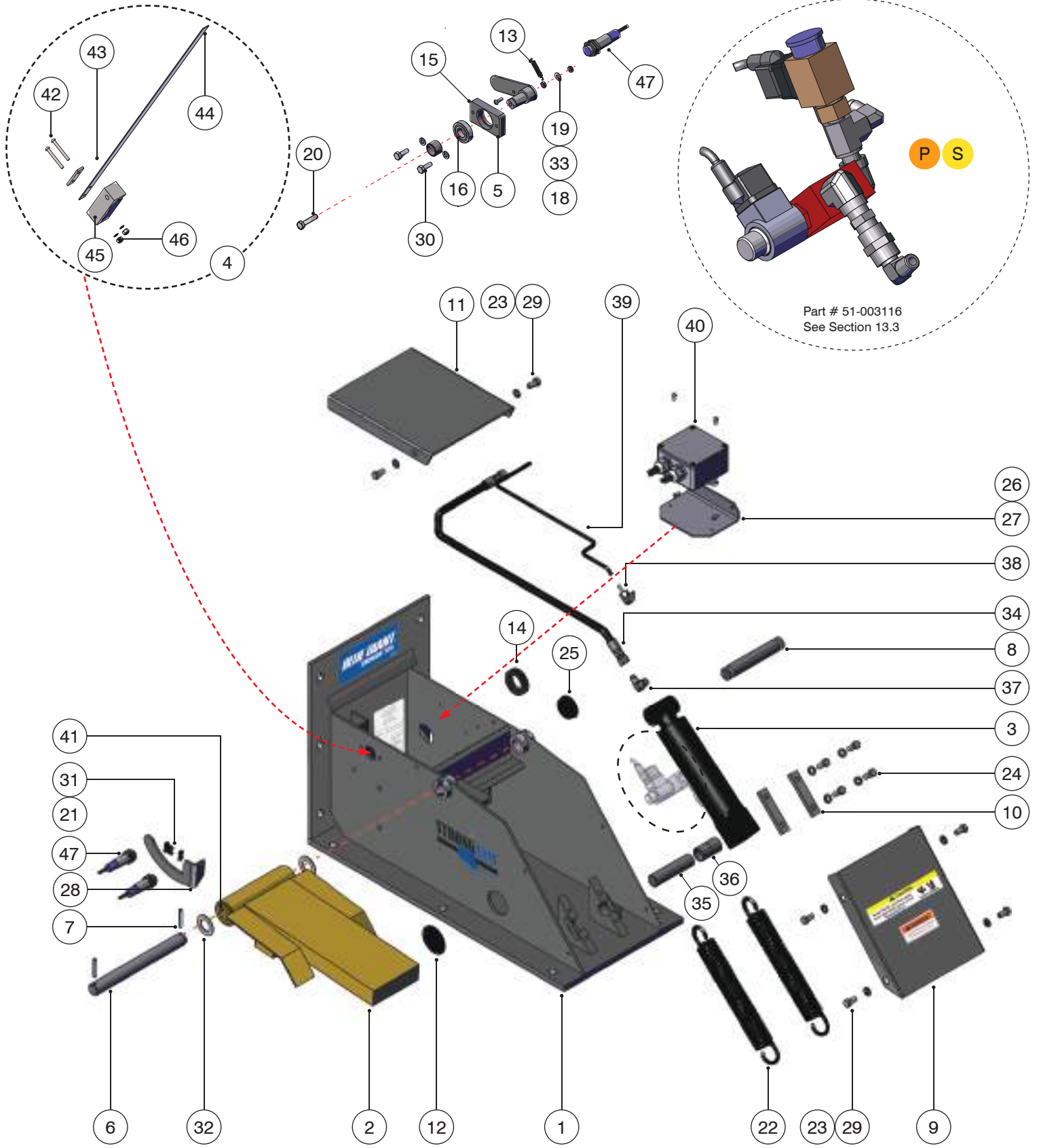

W

13.2 MECHANICAL ASSEMBLY - 51-013732 AND 51-013732-ZP CONT'D.

ITEM	QTY	PART NO.	DESCRIPTION
1	1	51-001977	Body Weldment
		51-001977-ZP	Body Weldment, Zinc Plated
2	1	51-012864	Arm Assembly 26" (660 mm) with Bushings Note: shipped loosely. Install as required.
3	1	035-662	Cylinder Assembly 2" dia. (51 mm)
4	1	51-012862	Sensor Wand Assembly
5	1	51-002052	Wand Axle Weldment
6	1	115-099	Hinge Pin
7	2	013-011-1	Spring Pin- SS
8	1	115-094	Spring Holder Pin
9	1	115-100	Front Cover
		115-100-ZP	Front Cover, Zinc Plated
10	2	113-096	Pivot Block Top Plate
11	1	115-103	Top Cover
		115-103-ZP	Top Cover, Zinc Plated
12	1	R3-93002	Plug Button 2" dia. x 1/8" (51 x 3 mm)
13	1	017-085	Extension Spring 1/2" OD x .34" THK x 1 1/4 LNG (13 x 9 x 32 mm)
14	1	037-079	Grommet 1 1/2" x 2 1/8" (38 x 54 mm)
15	1	51-002213	Bearing Square Block
16	1	018-640	Bearing- R10-2RS - ID: 5/8" OD :1 3/8" 11/32" (63 x 40 x 9 mm)
17	1	51-002306	Metallic Spacer
18	1	011-005	Screw Machine R/H slot # 8 - 32 x 1/2" (13 mm)
19	2	011-515	Hex Machine Screw Nut # 8 - 32
20	1	010-154	Hex Bolt 1/4 - 20 UNC X 1 1/4 LNG
21	5	012-202	Regular Lock Washer 0.25
22	2	017-034	Spring Wire OD: 1 5/8" x 1/4" Thick (26 x 6 mm)
23	10	012-201	Regular LW 0.375

ITEM	QTY	PART NO.	DESCRIPTION
24	4	010-039	Hex Bolt 3/8 - 16 UNC X 1 LNG
25	1	037-081	Hole Plug 1 3/4" dia. (44 mm)
26	1	51-002204	Junction Box Bracket
27	4	011-010	SL-RHMS # 10 - 24 x 0.4375
28	1	51-001945	Angular Position Cam
29	6	010-012	Hex Bolt 3/8 - 16 UNC x 3/4 LNG
30	2	010-000	Hex Bolt 0.25 - 20 UNC x 0.75 LNG
31	2	010-215	Machined Screw 1/4 - 20 x 5/8 LG
32	2	106-389	Spacer Washer
33	1	012-206	Flat Washer # 10 OD .5" (13 mm)
34	1	100-5000-41	Hose Assembly # 4 high pressure 22' (6.7 m)*
	1	100-5000-40	Hose Assembly # 4 high pressure 14' (4.3 m)†
35	1	115-307	Cylinder Pin
36	2	018-017	Bushing
37	1	034-511	Fitting, 90 DEG, Elbow *
38	1	040-007	Male Elbow 90 DEG 1/4 tube
39	1	090-909-2400	Tube Polyethylene 20' LG (6.1 m)
40	1	026-H22	TL85 - J-Box Harness* See Sec. 13.10
	1	026-H23	TL85 - J-Box Harness† See Sec. 13.10
41	2	018-013	Bushing, Bronze Oilite Flanged
42	2	011-007	Screw Machine R/H Slot
43	1	116-863	Mounting Block Top Plate
44	1	51-013611	Sensor Wand
45	1	51-002317	Wand Mounting Block
46	2	011-623	Lock Nut 8/32" Nylon Insert
47	3	028-200	Proximity Sensor

* W † P

P S

13.3 ARM LOCK AND PRESSURE SWITCH ASSEMBLY - 51-003116

ITEM	QTY	PART NO.	DESCRIPTION
1	1	033-508-24-K	Arm Lowering Valve
2	1	034-567	Fitting, 90 DEG, 3/8 NPT Female, 1/4 NPT Male
3	1	034-698	Fitting, Tee, 1/4 NPT Male, Female, Male
4	1	035-293-A	Pressure Switch
5	1	034-511	Adapter, 90 DEG, 1/4 NPT Male #5 JIC 37 DEG
6	1	034-566	Fitting, Elbow, 1/4 NPT Male, 1/4 NPT Female
7	1	034-507	Fitting, 3/8 NPT Male Straight
8	1	034-522	Female Coupling 3/8 NPT
9	1	034-599	Adapter, Elbow, 1/4 NPT Male, 3/8 NPT Male

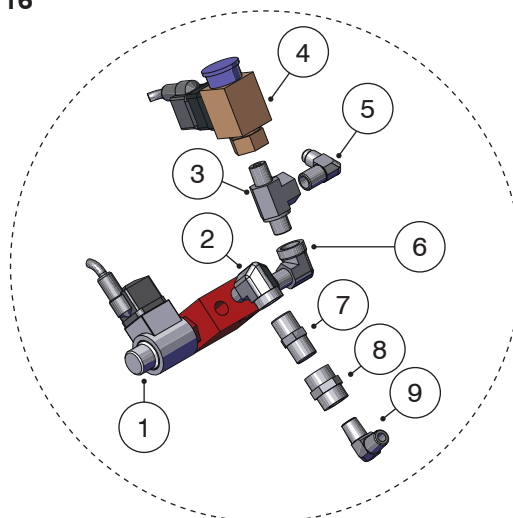



13.4 GENERAL DIMENSIONS

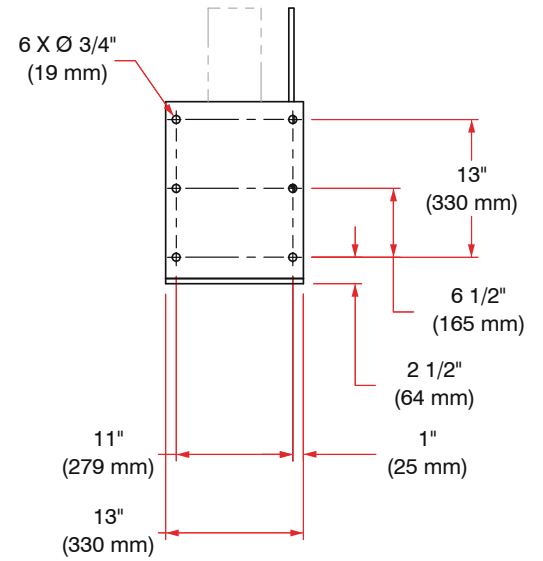
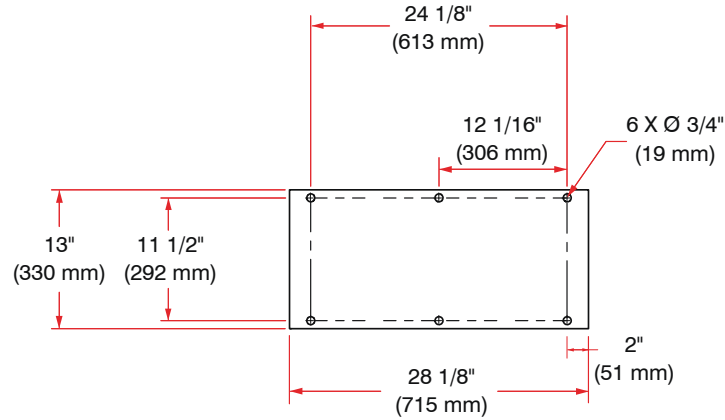
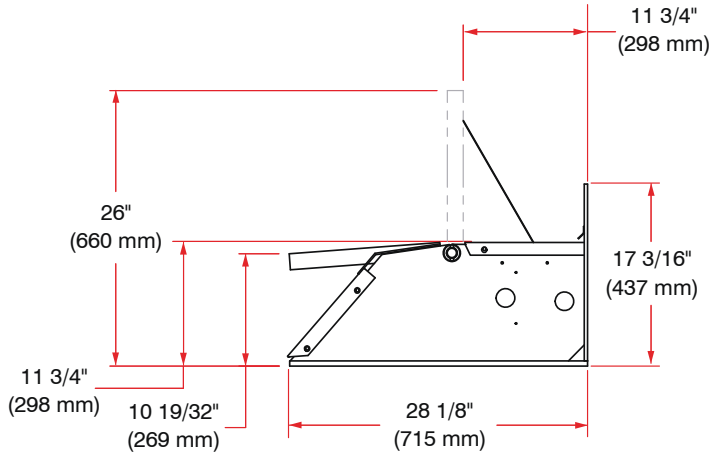

13.5 POWERPACK PART IDENTIFICATION - REMOTE WALL-MOUNTED

1 Full Powerpack Assembly

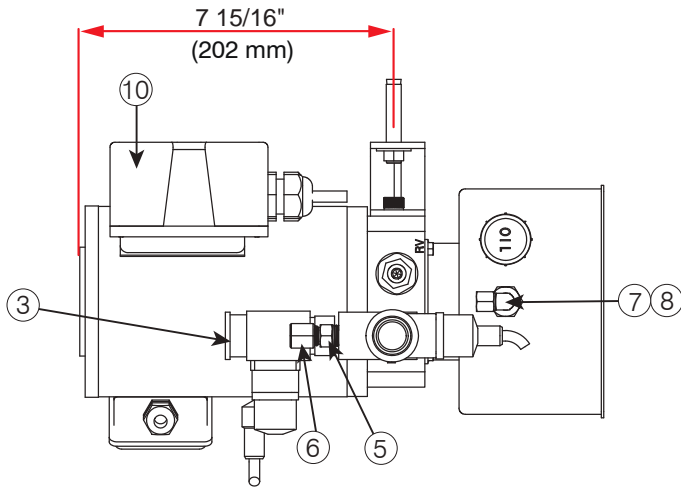

Top View - Wall Mount

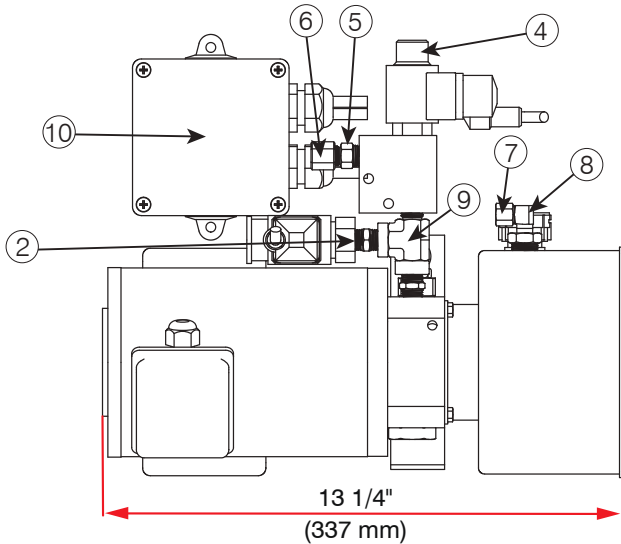

Front View - Wall Mount

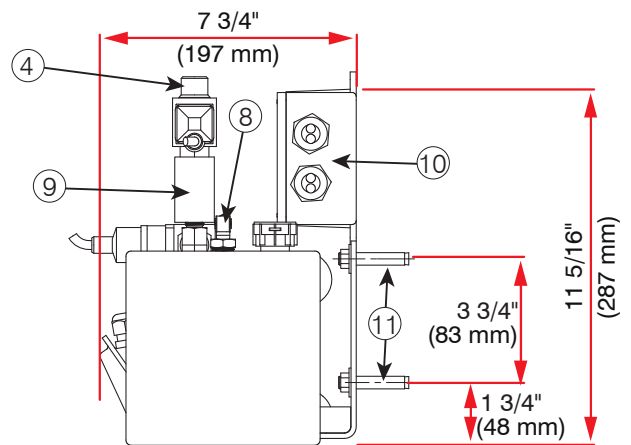

Side View (Tank End) - Wall Mount

TL85 POWERPACK - WALL BRACKET ASSEMBLY # 51-009410					
ITEM	QTY	PART NO.	DESCRIPTION	ITEM #1	
1	1	033-897K	TL85 PPACK - Wall	1PH-115-230V-50-60HZ	51-009410-1K
		033-899K		3PH-230-460V-50-60HZ	51-009410-2K
		033-900K		3PH-575V-60HZ	51-009410-3K
		033-897K		1PH-240V-50HZ	51-009410-4K
2	1	033-897-K	Adapter		
3	1	035-293-A	Pressure Switch		
4	1	033-508-24-K	Solenoid Valve, 24V DC Connector		

ITEM	QTY	PART NO.	DESCRIPTION
5	1	034-517	Straight steel adapter
6	1	035-249	Cap nut
7	1	034-726	Reducer bushing
8	1	040-007	Elbow, male, 90 deg for 1/4" dia rigid type tube
9	1	034-574	Fitting-tee
10	1	026-H21	Junction box assembly (see section 13.8)
11	2	010-114	Sleeve anchor (provided by installer)

13.6 POWERPACK PART IDENTIFICATION - REMOTE PIT-MOUNTED

① Full Powerpack Assembly

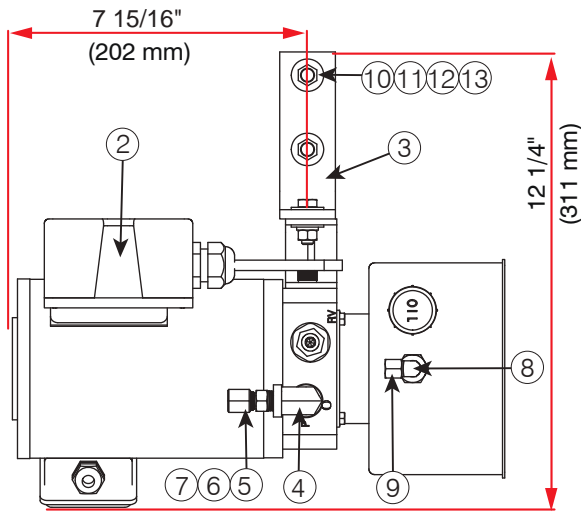

Top View – Pit Mount

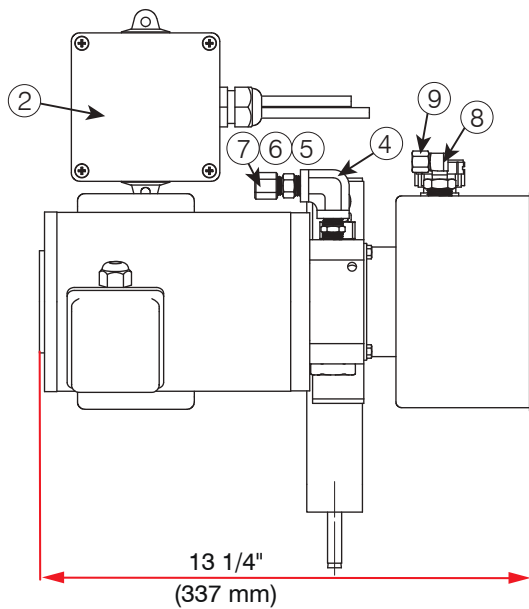

Front View – Pit Mount

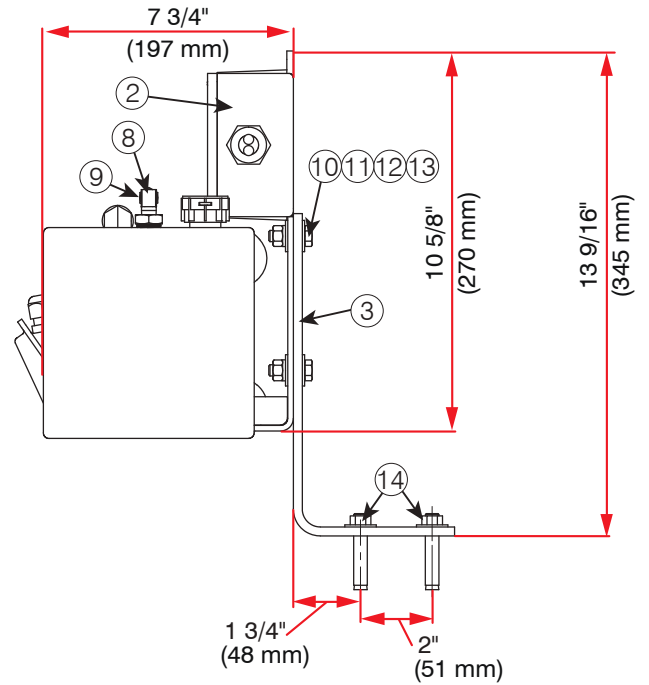

Side View (Tank End) – Pit Mount

TL85 POWERPACK - WALL BRACKET ASSEMBLY # 51-012894					
ITEM	QTY	PART NO.	DESCRIPTION	ITEM #1	
1	1	033-897K	TL85 POWERPACK - Pit	1PH-115-230V-50-60HZ	51-012895-1K
		033-899K		3PH-230-460V-50-60HZ	51-012895-2K
		033-900K		3PH-575V-60HZ	51-012895-3K
		033-897K		1PH-240V-50HZ	51-012895-4K
2	1	026-H25	Junction Box Assembly (See Section 13.9) Shipped loose. Install as required		
3	1	51-012818	L Bracket		
4	1	034-518	Fitting 90 Deg. Elbow		
5	1	034-560	Adaptor		

ITEM	QTY	PART NO.	DESCRIPTION
6	1	034-517	Straight Steel Adapter
7	1	035-249	Cap Nut
8	1	040-007	Elbow, Male, 90 DEG for 1/4" dia. Rigid Type Tube
9	1	034-726	Reducer Bushing
10	4	012-211	Washer, Flat, Zn Pld, 5/16
11	2	011-502	Nut, Hex, 5/16-18
12	2	012-200	Washer, Lock, Spg, Regular, 5/16
13	2	010-006	Screw, Cap, Hex Hd, 5/16-18x1x1, Gr5
14	2	010-114	Sleeve Anchor (provided by installer)



13.7 CONTROLS

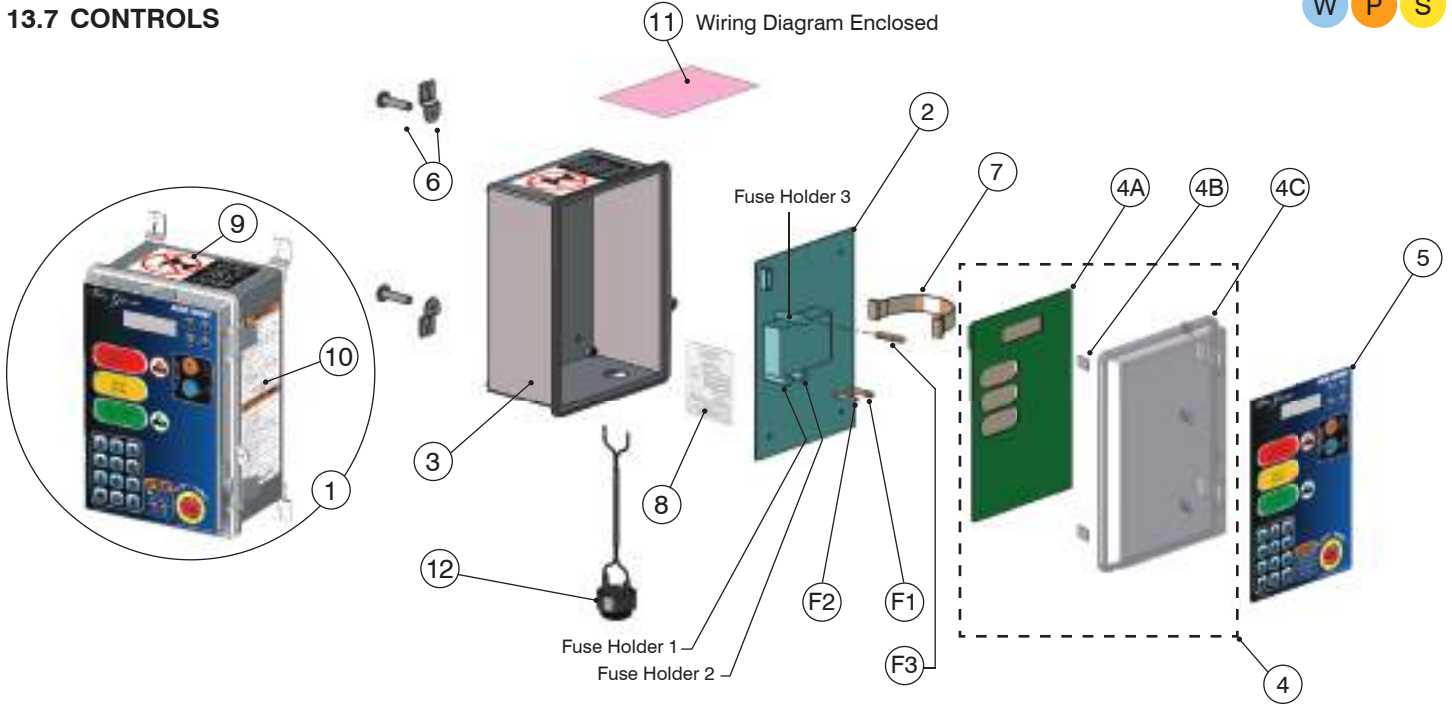

COMPLETE CONTROL STATION ASSEMBLY - ITEM 1 (Example BGG0T1115F)								
ITEM	SINGLE PHASE							
	◇	FUSE	QTY	PART NO.	DESCRIPTION	ASSY PART #	*	
2	F1	B	1	026-PB1115-R	Power Board Sub-Assembly † (1PH 115V 50-60HZ)	BGG0T1115	F	
	F2	E	1				S	
	F1	C	1	026-PB1230	Power Board Sub-Assembly † (1PH 230V 50-60HZ)	BGG0T1230	F	
	F2		1				S	
	THREE PHASE							
	2	◇	FUSE	QTY	PART NO.	DESCRIPTION	ASSY PART #	*
		F1	C	1	026-PB3230	Power Board Sub-Assembly † (3PH 230V 50-60HZ)	BGG0T3230	F
		F2		1				S
		F1	F	1	026-PB3400	Power Board Sub-Assembly † (3PH 400V 50-60HZ)	BGG0T3400	F
		F2		1				S
		F1	G	1	026-PB3460	Power Board Sub-Assembly † (3PH 460V 50-60HZ)	BGG0T3460	F
		F2		1				S
F1		H	1	026-PB3575	Power Board Sub-Assembly † (3PH 575V 60HZ)	BGG0T3575	F	
F2			1				S	
3				1	025-G010-M	Control Box Enclosure (Includes 4C)		
4			1	025-G014-V3-M	Transparent Cover Door (4C) and Touch Control Board (4A) (Serial # Required)			
4A			1	026-G021-M	Touch Control Board (Serial # Required)			
4B			5	025-062	Cable Tie Mount			
4C			1	025-G014	Transparent Cover Door			
5			1	038-245E	Face Decal	BGG0T245E	F	
							S	

* Language on decal: F = English / French S = English / Spanish

◇ Location on Power Board † Includes Fuses ‡ 115 Volt Control Box Shown

ITEM	QTY	PART NO.	DESCRIPTION
6	1	025-G010-1	Mounting Tabs with Hardware (1 pkg of 4)
7	1	026-G030	Ribbon Cable
8	1	038-284E	Decal, Serial Plate
			S
9	1	038-283EFS	Decal, Do Not Drill
10	1	038-853E	Warning Decal
			S
11	1	026-615-1	Anti-Static Poly Bag (Wiring Diagram Enclosed) (Serial # required for diagram)
12	1	026-G402-B	Audible Speaker
F3	1	026-037-1	Fuse, 2.5A, 700V, Fast-Blow 1/4" Glass

AS PER VOLTAGE - SEE ITEM 1

ITEM	QTY	PART NO.	DESCRIPTION
A	1	026-G100	Fuse, 15A, 250V, Time Delay for 1PH, 110-130V
B	1	026-G101	Fuse, 8A, 250V, Time Delay for 1PH, 208-240V
C	1	026-G102	Fuse, 0.5A, 250V, Time Delay for 1 and 3PH, 208-240V
D	1	026-G103	Fuse, 0.25A, 250V, Time Delay for 1PH, 208-240V
E	1	026-G104	Fuse, 0.75A, 250V, Time Delay for 1PH, 110-130V
F	1	026-G105	Fuse, 500mA, 700V, Fast Acting for 3PH, 380-415V
G	1	026-G106	Fuse, 400mA, 700V, Fast Acting for 3PH, 440-480V
H	1	026-G107	Fuse, 315mA, 700V, Fast Acting for 3PH, 575-600V

13.8 JUNCTION BOX WITH REMOTE I/O - REMOTE WALL-MOUNTED POWERPACK

W

TL85 REMOTE I/O HARNESS ASSEMBLY # 026-H21			
ITEM	QTY	PART NO.	DESCRIPTION
1	1	025-G020-1M	Junction Box 4" x 4" (2 Holes)
2	2	025-174	PG16 Cable Gland
3	2	025-177	PG16 Metal Locknut
4	2	025-179	PG16 Multi-Hole Seal (2 Holes)
5	1	026-G025M	Remote I/O Board (Resistor)
6	1	038-279	Circuit Board Decal
7	2	026-G074	Solenoid Valve Connector - 5' (1.52 m)
8	1	026-H16-1	Communication Cable to Blue Genius™ - 30' (9.14 m)
9	1	026-G034-2400	Unshielded Cable #20 AWG - 7 Wire - 20' (6.09 m)

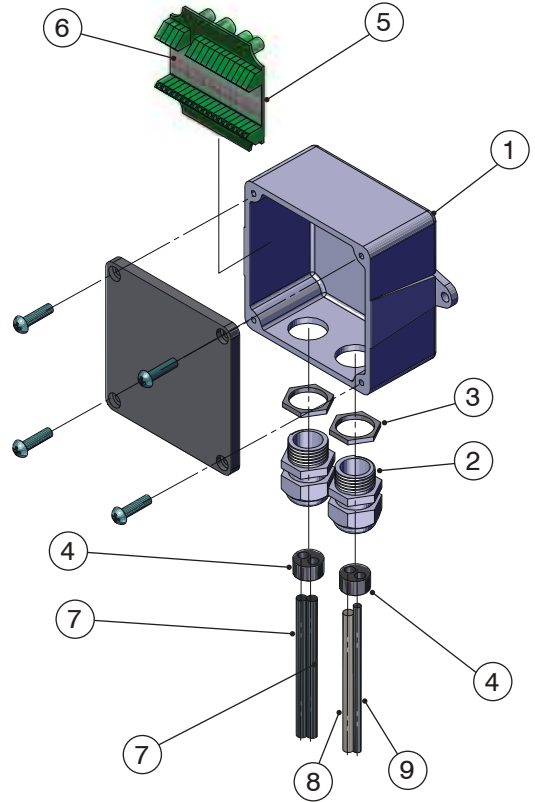

13.9 JUNCTION BOX WITH REMOTE I/O - REMOTE PIT-MOUNTED POWERPACK

P

TL85 REMOTE I/O HARNESS ASSEMBLY # 026-H25			
ITEM	QTY	PART NO.	DESCRIPTION
1	1	025-G020-1N	Junction Box 4" x 4" (3 Holes)
2	2	025-174	PG16 Cable Gland
3	2	025-177	PG16 Metal Locknut
4	2	025-175	PG16 Multi-Hole Seal (3 Holes)
5	1	025-176	PG9 Metal Locknut
6	1	025-173	Cable Gland 2-8mm Range
7	1	026-G025M	Remote I/O Board (Resistor)
8	1	038-279	Circuit Board Decal
9	1	028-199	Proximity Sensor (30mm Unshielded)
10	2	026-G074	Solenoid Valve Connector - 5' (1.52 m)
11	1	026-H16-1	Communication Cable to Blue Genius™ - 30' (9.14 m)
12	3	028-200	Proximity Sensor (18mm Shielded) 10-30V

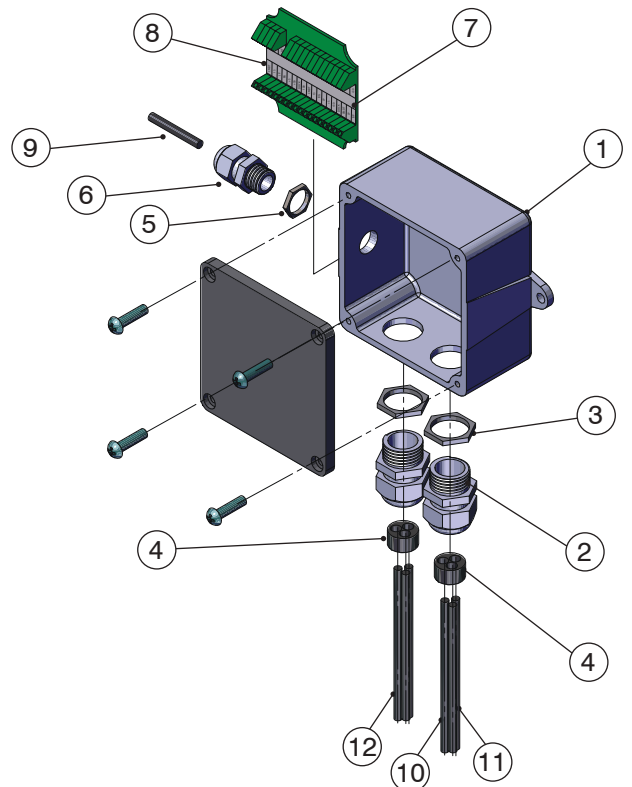



13.10 JUNCTION BOX HARNESS

TL85 JUNCTION BOX ASSEMBLY - WALL (IN UNIT) # 026-H22			
ITEM	QTY	PART NO.	DESCRIPTION
1	1	025-G020-1M	Junction Box 4" x 4" (2 Holes)
2	2	025-174	PG16 Cable Gland
3	2	025-177	PG16 Metal Locknut
4	1	025-179	PG16 Multi-Hole Seal (2 Holes)
5	1	025-175	PG16 Multi-Hole Seal (3 Holes)
6	1	025-172	Terminal Strip - 12 Poles
7	1	028-199	Proximity Sensor (30mm Unshielded)
8	3	028-200	Proximity Sensor (18mm Shielded) 10-30V
9	1	026-G034-2400	Unshielded Cable #20 AWG - 7 Wire - 20' (6.09 m)

TL85 JUNCTION BOX ASSEMBLY - PIT (IN UNIT) # 026-H23			
4	-1	025-179	PG16 Multi-Hole Seal (2 Holes)
5	+1	025-172	PG16 Multi-Hole Seal (3 Holes)
9	-1	026-G034-2400	Unshielded Cable #20 AWG - 7 Wire - 20' (6.09 m)
10	+2	026-G074	Solenoid Valve Connector - 5' (1.52 m)

13.11 JUNCTION BOX DIMENSIONS

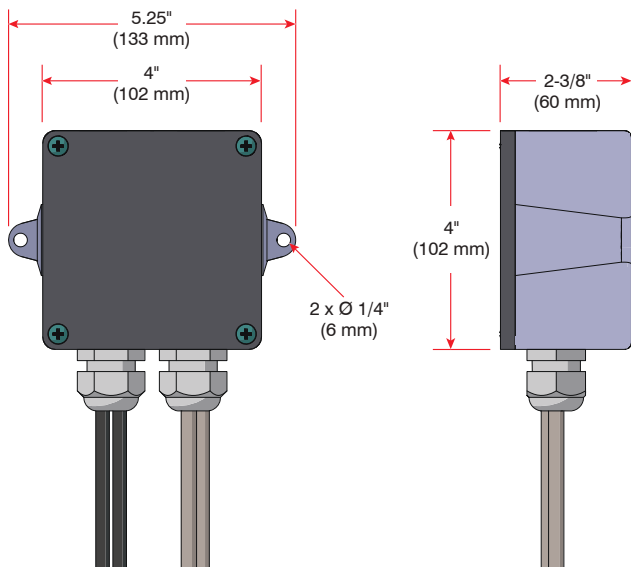

Junction Box - Front View

Junction Box - Side View

TL85 JUNCTION BOX ASSEMBLY - WALL (IN UNIT)

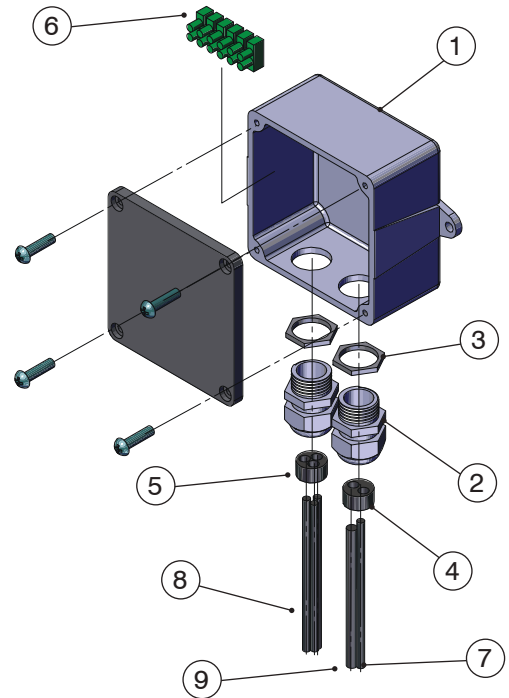

TL85 JUNCTION BOX ASSEMBLY - PIT (IN UNIT)

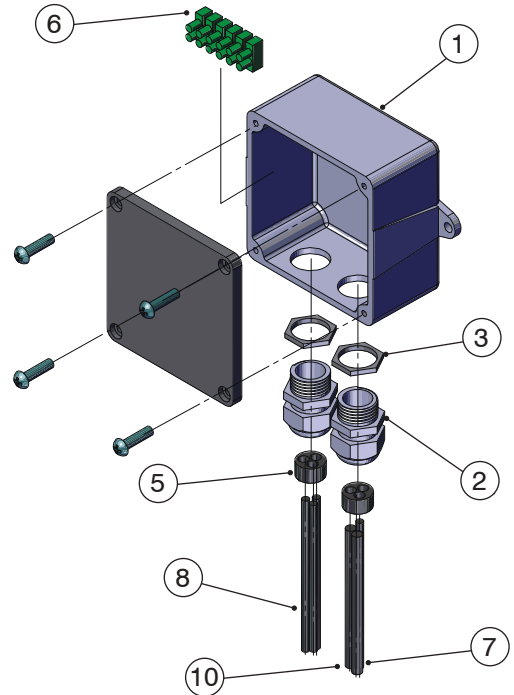

NOTE: 026-H23 contains the same parts and quantity of parts as 026-H22, except where noted by a + or -.



13.12 RESTRAINT INTERLOCK SENSOR

- Ties sequence of dock leveler to vehicle restraint operation
- Loading dock safety is improved with accurate operation sequence
- Interior traffic light and restraint release operation relies on interlock capability
- Mounted at parked position of any leveler

Alternatively, if dock leveler is not equipped, this function can be tied to overhead door operation sequence. In lieu of the interlock sensor, mount a photo eye at the door closed position.

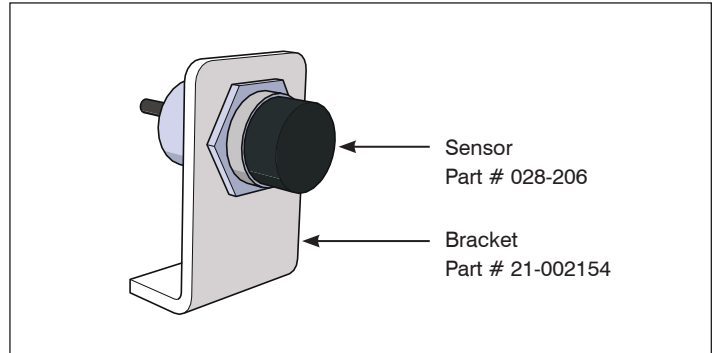

13.13 EXTERIOR TRAFFIC LIGHT / MIRROR IMAGE SIGN



The LED traffic lights and mirror image drive warning sign improve loading dock safety.

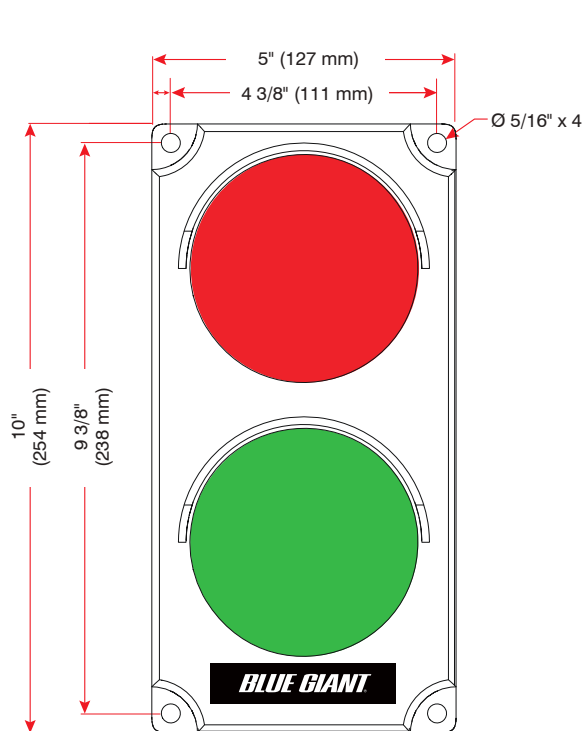

Exterior driver traffic light, part # 032-806.

NOTE: Mount to a flat surface. DO NOT deform light housing with irregular wall surface.

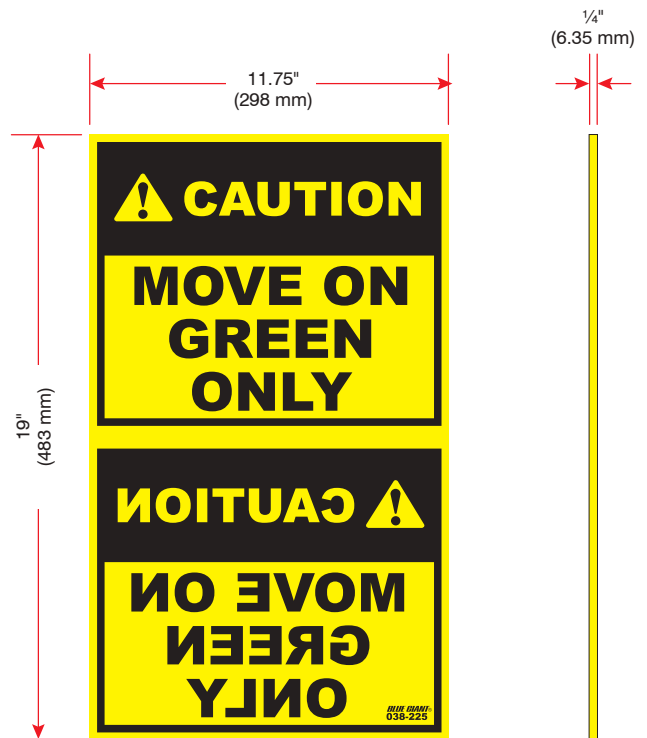

Exterior driver warning sign, part # 038-225.
(French 038-225F / Spanish 038-225S / Portuguese 038-225P)



14.0 ALTERNATIVE POWERPACK OPTIONS

The TL85 is also available with a self-contained powerpack to suit site conditions.

14.1 MECHANICAL ASSEMBLY (SELF-CONTAINED POWERPACK)- 51-013731

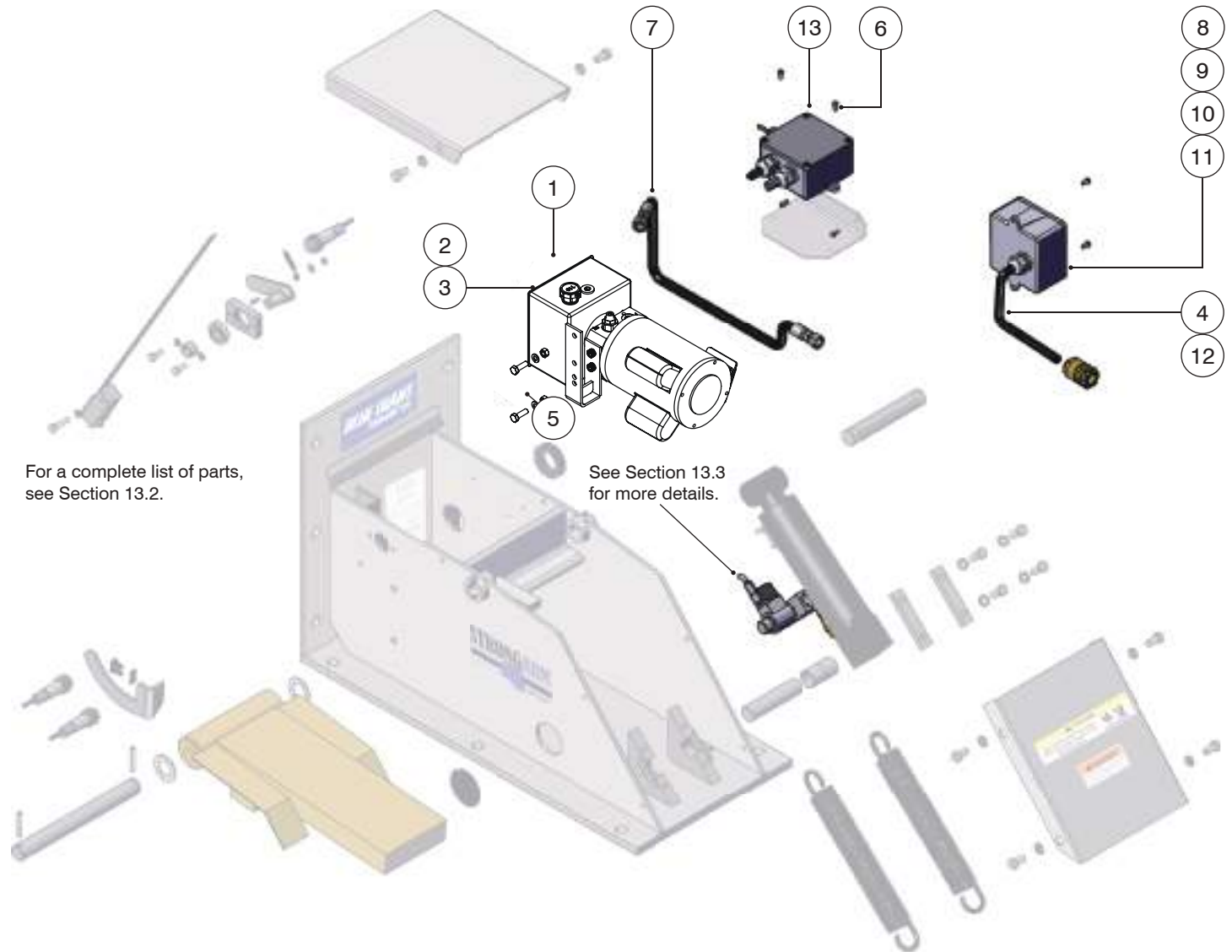

For a complete list of parts, see Section 13.2.

See Section 13.3 for more details.

The following items and quantities are unique to the TL85 with self-contained powerpack.

ITEM	QTY	PART NO.	DESCRIPTION
1	1	033-897K	Powerpack, 1PH-115-230V-50-60HZ
		033-899K	Powerpack, 3PH-230-460V-50-60HZ
		033-900K	Powerpack, 3PH-575V-60HZ
2	1	035-436	Tank and Bolts (Included in Item 1)
3		012-200	Washer,Lock,SpG,Regular,5/16,
4	1	026-H07-1	Harness with Cable, 1PH
		026-H08	Harness with Cable, 3PH
5	6	010-006N	Screw,Cap,Hex Hd,5/16-18x1x1,Gr5

ITEM	QTY	PART NO.	DESCRIPTION
6	6	011-010	SL-RHMS #10 - 24 x 0.4375
7	1	100-5000-5	Hose Assembly #4 High Pressure 20" (.5m)
8	1	025-G020-C	Junction Box 4" x 4" (102 x 102 mm)
9	1	025-174	PG16 Cable Gland
10	1	025-177	PG16 Metal Locknut
11	1	025-172	Terminal Strip
12	1	025-016	Fitting SR-50-625 3/4" (19 mm)
13	1	026-H25	J-Box (See Sec. 13.9)



15.0 VEHICLE RESTRAINT TROUBLESHOOTING



WARNING

Do not attempt to install, make repairs or adjustments. Only a trained and authorized service technician should perform the installation process. Contact your local dealer or distributor for assistance.

PROBLEM	PROBLEM CAUSE
<p>The restraint arm will not rise when the ENGAGE button is touched. The motor runs, and the LED lights on the control panel and exterior traffic light are both red.</p>	<ol style="list-style-type: none"> 1. Faulty wiring or connection. Refer to electrical wiring diagram. 2. Hydraulic oil level is low or depleted. Check level and refill as needed. 3. Leaking or disconnected hydraulic hose. 4. Faulty powerpack pump. Replace if necessary. 5. The powerpack pressure adjustment is out of range. 6. If the motor is three-phase, check its rotation. 7. Damaged lift cylinder. 8. Energized solenoid valve. 9. The manual release valve is slightly open or debris has collected on the seat of the seal.
<p>The restraint arm will not rise when the ENGAGE button is touched and the motor does not run. The LED lights on the control panel and exterior traffic light are both red.</p>	<ol style="list-style-type: none"> 1. Faulty wiring or connections. Refer to electrical wiring diagram. 2. Faulty motor contactor. 3. Faulty powerpack pump. Replace if necessary. 4. The system lock has been activated. Enter the release code. 5. Motor connected to M2, program is M1.
<p>The restraint arm rises but does not lock in between 45° - 90° position.</p>	<ol style="list-style-type: none"> 1. Faulty wiring or loose connections. 2. Faulty locking solenoid. Replace if necessary. 3. Faulty 45° sensor. 4. The manual release valve is slightly open or debris has collected on the seat of the seal.
<p>The restraint arm does not lower when the operator touches the RELEASE button.</p>	<ol style="list-style-type: none"> 1. Faulty wiring or connections. Refer to electrical wiring diagram. 2. Power loss. Refer to the Emergency Lowering Procedure for manual release of the locking mechanism. 3. The restraint interlock sensor (home/lip) is inactive. 4. Faulty touch sensor. 5. The arm release option may be password-protected. 6. Overhead door not closed (optional feature- may not apply). 7. Fault codes, check code number.
<p>The restraint functions properly and the LCD screen works but the control panel lights do not come on.</p>	<ol style="list-style-type: none"> 1. The power source for the control panel lights is damaged. Replace the control board(s).
<p>The restraint is engaged but the control panel light remains RED.</p>	<ol style="list-style-type: none"> 1. The restraint interlock sensor (home/lip) is inactive or wired incorrectly. 2. The deck has not been deployed. 3. The restraint interlock sensor (home/lip) is not installed. 4. STOP button has been touched.



15.0 VEHICLE RESTRAINT TROUBLESHOOTING CONT'D.



WARNING

Do not attempt to install, make repairs or adjustments. Only a trained and authorized service technician should perform the installation process. Contact your local dealer or distributor for assistance.

PROBLEM	PROBLEM CAUSE
<p>Exterior traffic lights are dim, displaying incorrectly (wrong color) or malfunctioning (only one light works).</p>	<ol style="list-style-type: none"> 1. Check wiring to lights. Ensure that the +24 red exterior light is connected to terminal # 12 on the control terminal strip label 1 to 14 and that the +24 green light is connected to terminal #13 and the common of the lights are connected to terminal #14. 2. Lights common wire is terminated in wrong terminal (other than #14).
<p>The restraint is in the parked position and the inside light is green with yellow light flashing.</p>	<ol style="list-style-type: none"> 1. The restraint is put in the bypass mode with the restraint interlock sensor inactive.
<p>LCD screen displays the message 'Restraint is Bypassed'. The control panel lights are green and flashing yellow while the exterior traffic light is red.</p>	<ol style="list-style-type: none"> 1. The dock leveler is either not parked or the home sensor does not detect it as being in the parked position. 2. Dock is in bypass mode and home sensor is inactive.
<p>The restraint arm raises when the ENGAGE button is touched, but the wand has not been pushed back by the ICC bar.</p>	<ol style="list-style-type: none"> 1. The wand sensor is incorrectly wired or not connected. 2. The wand sensor is out of the range of the target mechanism.
<p>The motor continues to run after restraint arm has fully raised or stops at ICC bar in range.</p>	<ol style="list-style-type: none"> 1. The pressure switch is set too high.
<p>The restraint arm doesn't rise immediately when the ENGAGE button is touched.</p>	<ol style="list-style-type: none"> 1. Air is trapped in the lift cylinder or hoses.
<p>The blue light inside the Blue Genius™ does not light up and the LCD screen is blank.</p>	<ol style="list-style-type: none"> 1. Check all three fuses labeled F1, F2 and F3. 2. Check incoming power for proper voltage.



16.0 BLUE GENIUS™ LCD MESSAGES



WARNING

Do not attempt to install, make repairs or adjustments. Only a trained and authorized service technician should perform the installation process. Contact your local dealer or distributor for assistance.

MESSAGE	EXPLANATION
'Blue Genius Warning'	<ol style="list-style-type: none"> 1. Follow the onscreen instructions to troubleshoot the problem. If the message repeats after following instructions, then the fault is still present.
During self test mode the following message appears: 'Remote I/O Bad' or 'Rem I/O com 10'	<ol style="list-style-type: none"> 1. Faulty wiring, communication cable not connected or damaged. 2. Communication chip(s) faulty. 3. Electrical noise interference may be present.
'Please restore Dock Leveler'	<ol style="list-style-type: none"> 1. Restraint interlock sensor (home/lip) is in-active, out of range, or not connected. 2. Faulty wiring. 3. Dock not in stored/home position.
'ICC Bar not in Range'	<ol style="list-style-type: none"> 1. The wand has not been deployed or is broken. 2. The wand sensor's input wire is shorted to (+24). 3. Input to I3 has false signal.
'Fault 43'	<ol style="list-style-type: none"> 1. Pressure switch is active before the restraint arm has reached 45°.
'Fault 44'	<ol style="list-style-type: none"> 1. Home sensor active, 45° sensor becomes inactive.
'Fault 45'	<ol style="list-style-type: none"> 1. Pressure switch becomes active when engage button pressed with home and 45° sensors still active.
'Restraint Arm Blocked' Followed by: 'Restore Restraint, press 'SEL' to continue, Blue Genius™ Warning' (repeats)	<ol style="list-style-type: none"> 1. Restraint arm failed to lower completely. Check for debris. 2. The lower sensor is out of range or faulty. 3. The pressure down valve is not active on time-out.
'Restraint is Engaged' Followed by: 'Dock Leveler Restored', 'Ready to Deploy Deck'. (repeats)	<ol style="list-style-type: none"> 1. The Engaged button has been touched and vehicle restraint is in locked position.
During self test mode the following message appears: 'Remote I/O Bad'	<ol style="list-style-type: none"> 1. Faulty wiring, check communication cable wires for loose connections. 2. Remote I/O is faulty, replace. 3. Blue Genius™ power board is faulty, replace. <p>NOTE: Both boards may be faulty at the same time.</p>



17.0 WIRING DIAGRAMS

NOTICE

The following wiring diagrams are sample configurations only. Wiring diagrams specific to your needs will be provided inside the control panel and/or as part of your submittal package.

17.1 WIRING DIAGRAM—115V SINGLE PHASE

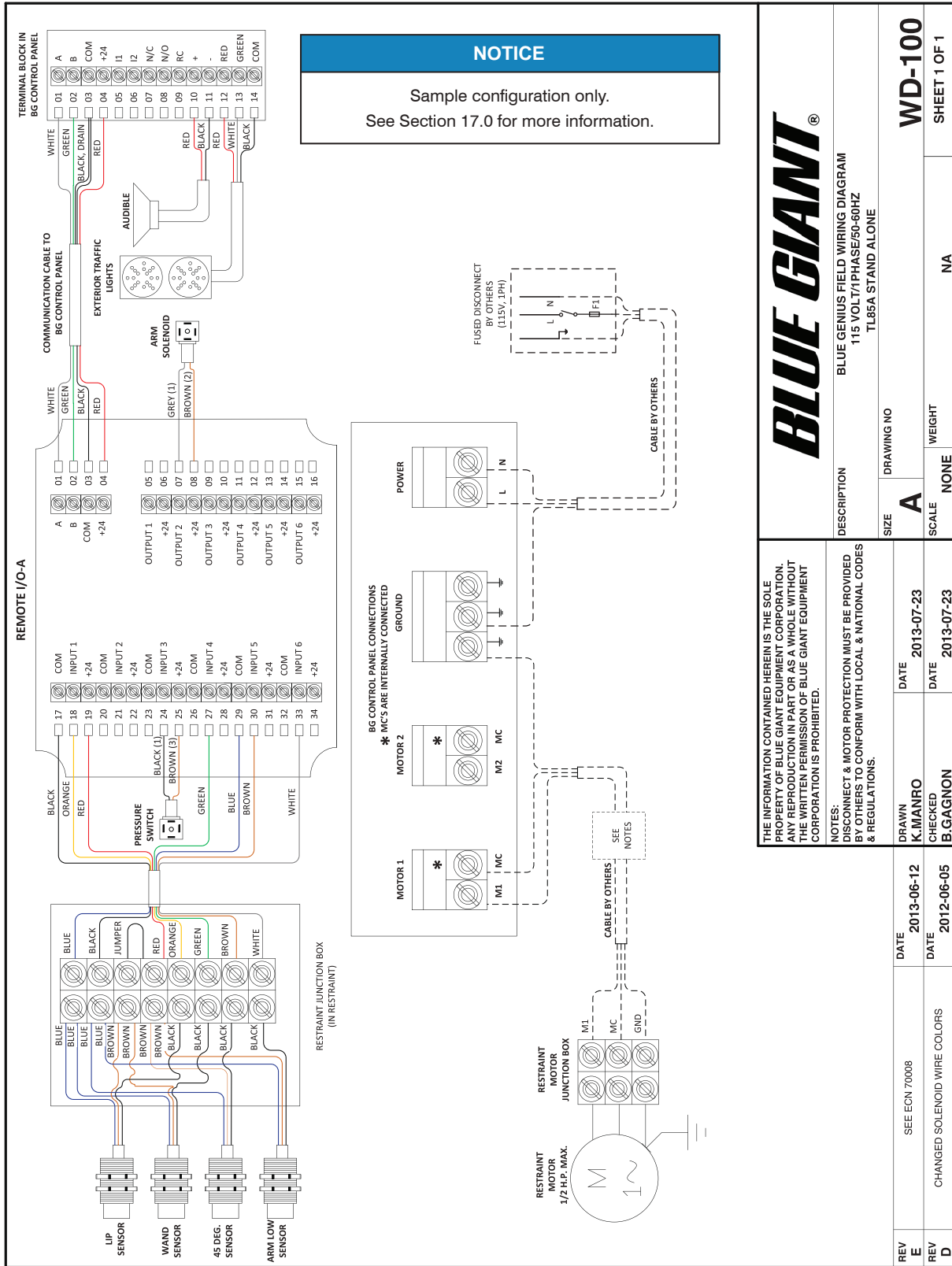

*Wiring diagram may be used for Remote Pit-Mounted Powerpacks. Though some components differ in layout, wiring and function remain the same. See Section 17.0 for more information.

17.2 WIRING DIAGRAM—230-575V THREE PHASE

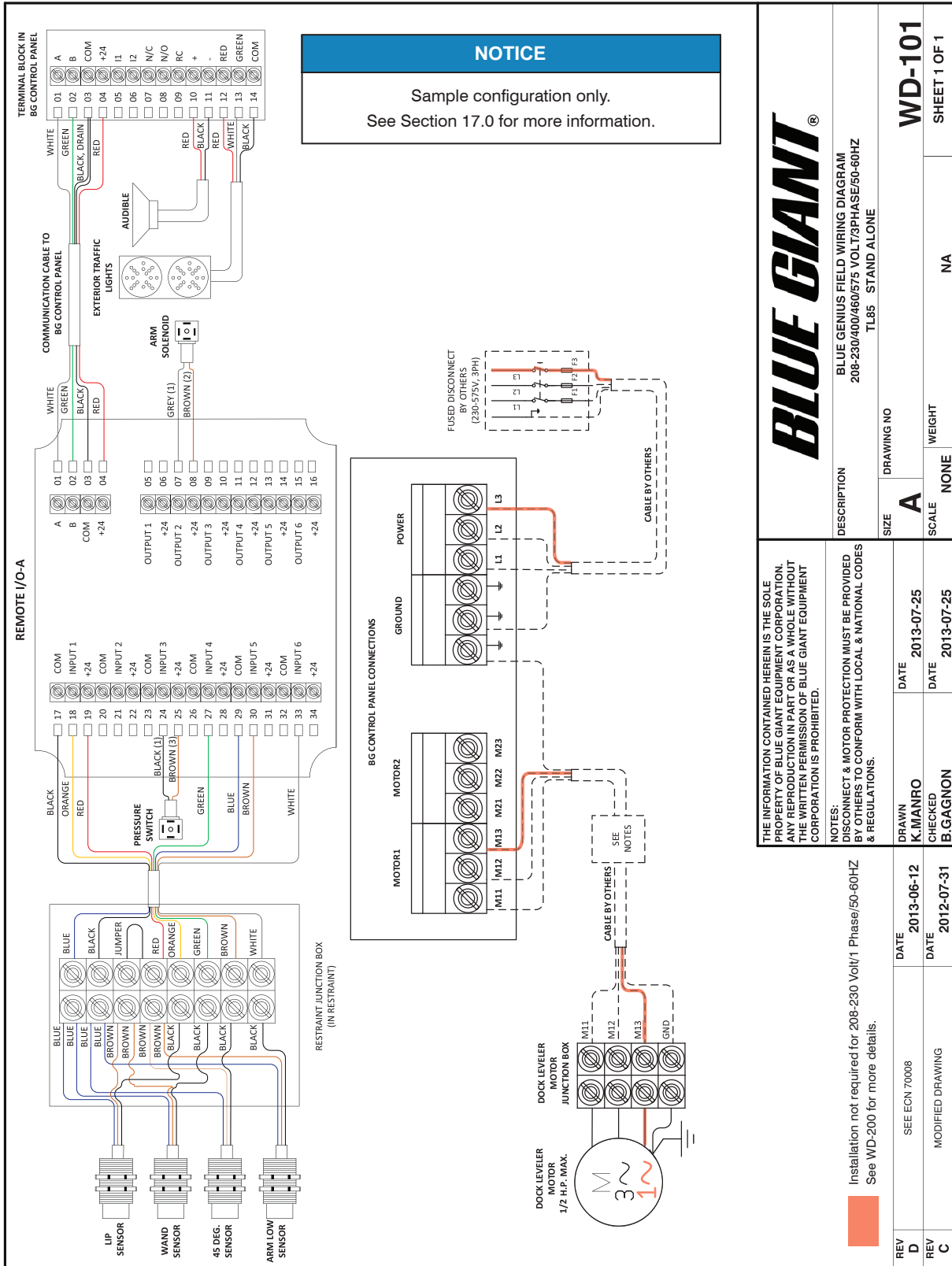

*Wiring diagram may be used for Remote Pit-Mounted Powerpacks. Though some components differ in layout, wiring and function remain the same. See Section 17.0 for more information.

17.3 WIRING DIAGRAM—SELF-CONTAINED POWERPACK—115V SINGLE PHASE

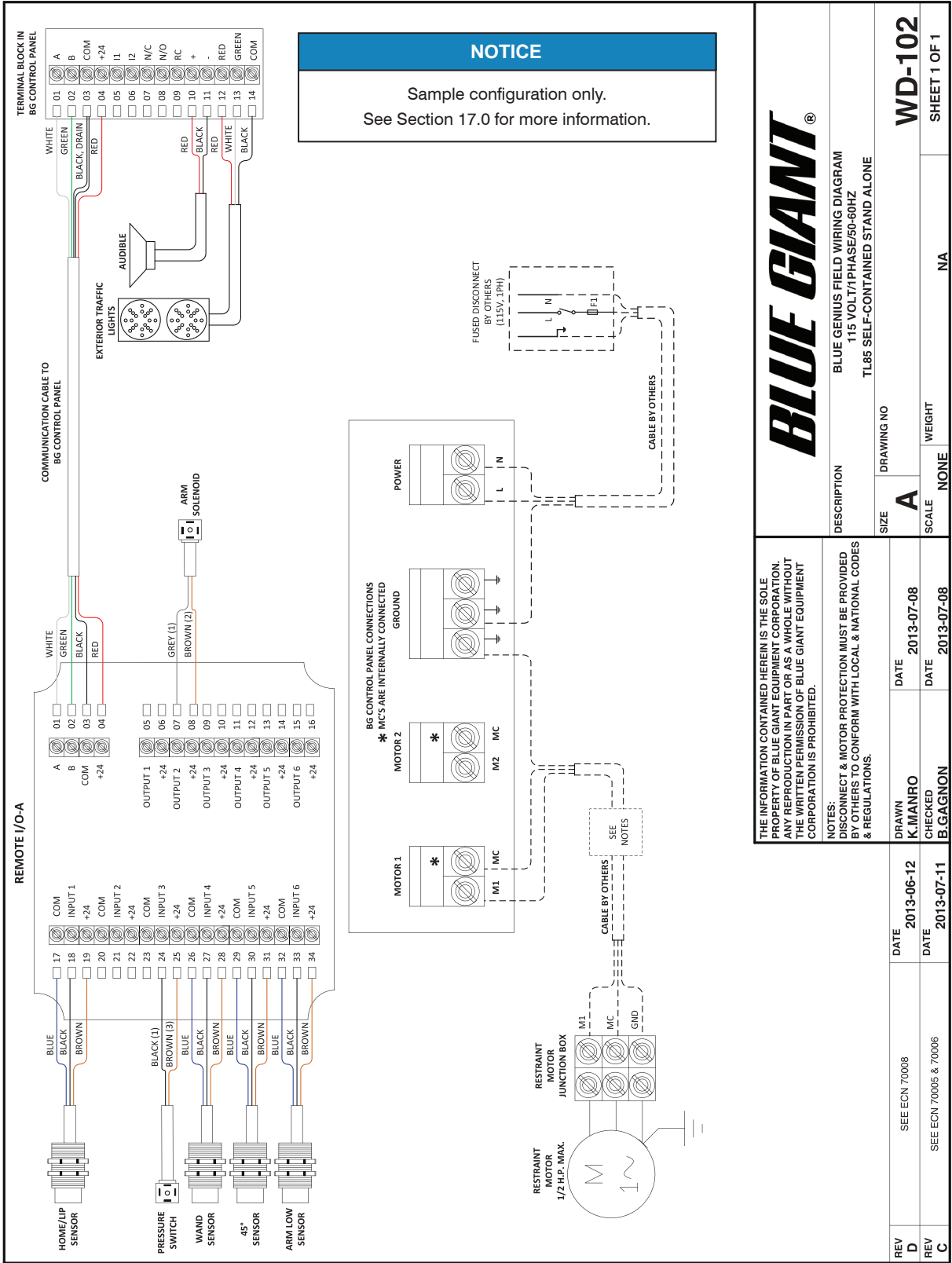

<p>BLUE GIANT®</p> <p>DESCRIPTION: BLUE GENIUS FIELD WIRING DIAGRAM 115 VOLT/1PHASE/50-60HZ TL85 SELF-CONTAINED STAND ALONE</p>		DRAWING NO		WD-102	
		SCALE		SHEET 1 OF 1	
<p>THE INFORMATION CONTAINED HEREIN IS THE SOLE PROPERTY OF BLUE GIANT EQUIPMENT CORPORATION. ANY REPRODUCTION IN PART OR AS A WHOLE WITHOUT THE WRITTEN PERMISSION OF BLUE GIANT EQUIPMENT CORPORATION IS PROHIBITED.</p> <p>NOTES: DISCONNECT & MOTOR PROTECTION MUST BE PROVIDED BY OTHERS TO CONFORM WITH LOCAL & NATIONAL CODES & REGULATIONS.</p>		SIZE	WEIGHT	NA	
REV D	DATE 2013-06-12	DRAWN K. MANRO	DATE 2013-07-08	SCALE NONE	
REV C	DATE 2013-07-11	CHECKED B. GAGNON	DATE 2013-07-08		

17.4 WIRING DIAGRAM—SELF-CONTAINED POWERPACK—230-570V THREE PHASE

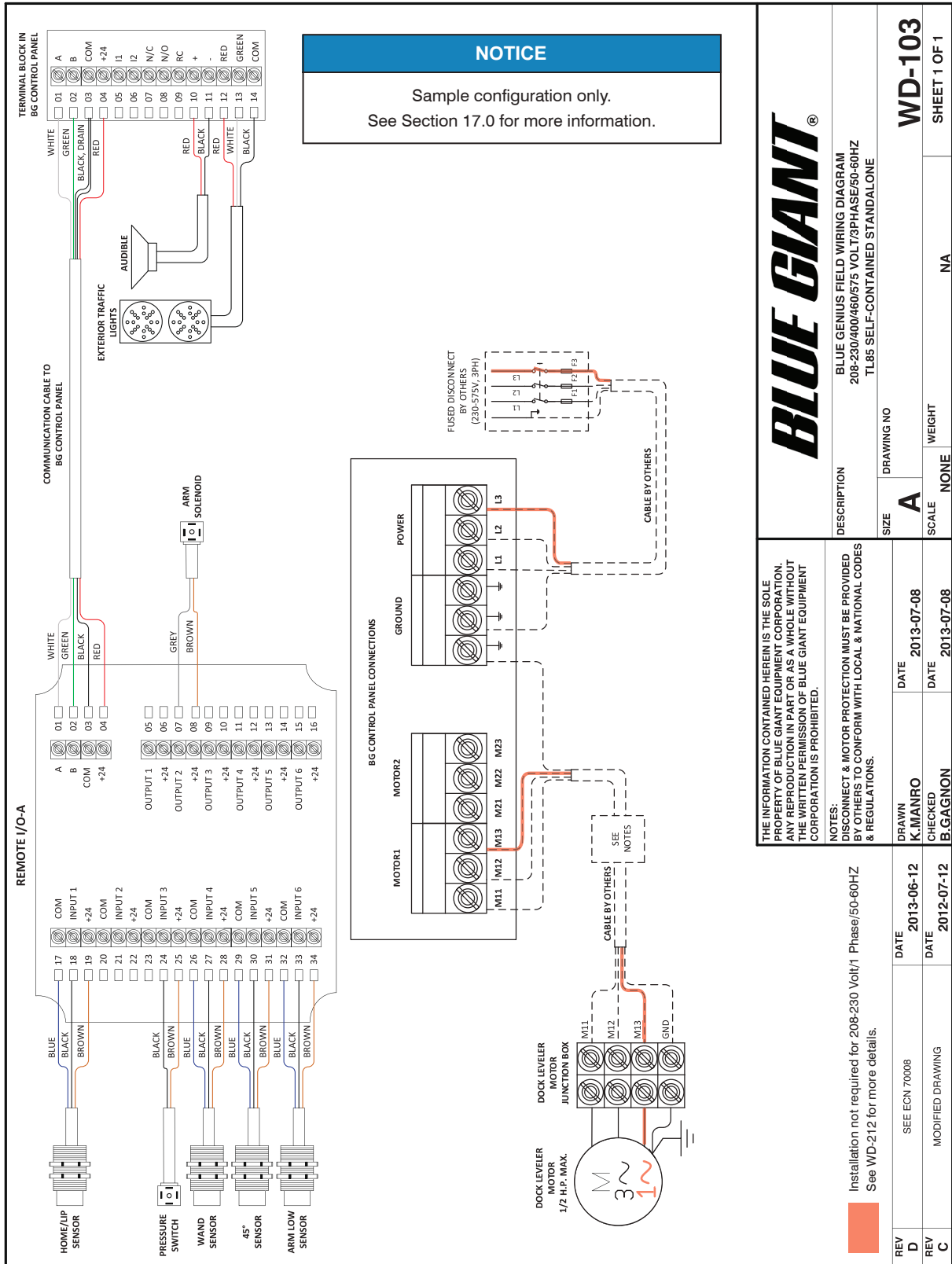

<p>BLUE GIANT®</p> <p>DESCRIPTION: BLUE GENIUS FIELD WIRING DIAGRAM 208-230/400/460/575 VOLT/3PHASE/50-60HZ TL85 SELF-CONTAINED STANDALONE</p>		SIZE: A	DRAWING NO: WD-103
		SCALE: NONE	WEIGHT: NA
<p>THE INFORMATION CONTAINED HEREIN IS THE SOLE PROPERTY OF BLUE GIANT EQUIPMENT CORPORATION. ANY REPRODUCTION IN PART OR AS A WHOLE WITHOUT THE WRITTEN PERMISSION OF BLUE GIANT EQUIPMENT CORPORATION IS PROHIBITED.</p> <p>NOTES: DISCONNECT & MOTOR PROTECTION MUST BE PROVIDED BY OTHERS TO CONFORM WITH LOCAL & NATIONAL CODES & REGULATIONS.</p>		DATE: 2013-07-08	DATE: 2013-07-08
<p>Installation not required for 208-230 Volt/1 Phase/50-60HZ See WD-212 for more details.</p>	<p>DATE: 2013-06-12</p> <p>DATE: 2012-07-12</p>	<p>DRAWN: K. MANIRO</p> <p>CHECKED: B. GAGNON</p>	<p>SCALE: NONE</p> <p>WEIGHT: NA</p>

BLUE GIANT[®]
BLUE GIANT EQUIPMENT CORPORATION

Corporate 410 Admiral Blvd
Mississauga, ON, Canada L5T 2N6
t 905.457.3900 f 905.457.2313

USA 6350 Burnt Poplar Road
Greensboro, NC 27409
www.bluegiant.com