

OWNER'S MANUAL

BLUE GIANT INTERLOCK CHOCK™



ACTUAL PRODUCT MAY NOT APPEAR EXACTLY AS SHOWN

WARNING

Do not operate or service this product unless you have read and fully understand the entire contents of this manual. Failure to do so may result in bodily injury or death.

BLUE GIANT®

STARTING FROM AUGUST 14, 2020 / SERIAL # 467201

ISSUE DATE: SEPTEMBER 28, 2023 REV. 2.1 (PART # 038-1125E)

Table of Contents

1.0	ABOUT THE INTERLOCK CHOCK	5
1.1	OWNER'S PURCHASE RECORD	5
2.0	INTRODUCTION	6
2.1	WARRANTY INFORMATION	6
2.2	EXCLUSION OF LIABILITY	6
2.3	MANUFACTURER'S NOTE	7
2.4	OWNER'S RESPONSIBILITY	7
3.0	SAFETY MESSAGE COLOR IDENTIFICATION	9
3.1	OPERATIONAL SAFETY WARNINGS	9
4.0	LOCKOUT / TAGOUT PROCEDURE AND RULES	11
4.1	ELECTROSTATIC SENSITIVE DEVICE PROTECTION POLICY	12
5.0	INDEPENDENT TYPE CONTROL STATION	13
5.1	PUSH BUTTON CONTROLS	13
5.2	BUTTON FUNCTION	14
6.0	OPERATING INSTRUCTIONS	15
6.1	PLACE WHEEL CHOCK	15
6.2	REMOVE WHEEL CHOCK	15
7.0	MAINTENANCE	17
7.1	PLANNED MAINTENANCE PROGRAM (PMP)	17
7.2	OPERATOR DAILY INSPECTION	17
7.3	ROUTINE SERVICING AND MAINTENANCE	17
7.4	PLANNED MAINTENANCE PROGRAM INTERVALS	17
7.5	MAINTENANCE SEQUENCE	17
7.6	DAILY MAINTENANCE PROCEDURES (DMP) CHECKLIST	18
8.0	RECOMMENDED SPARE PARTS	19
9.0	DECAL IDENTIFICATION AND LOCATION	21
9.1	OPERATION PLACARDS	21
10.0	EQUIPMENT COMPONENT ILLUSTRATIONS	24
10.1	COMPONENTS AS SHIPPED CHECKLIST	24
10.2	GENERAL DIMENSIONS	25
10.3	CONTROLS	26
10.4	JUNCTION BOX W/REMOTE I/O	27
10.5	JUNCTION BOX ASSEMBLY	28
10.6	DOCK INTERLOCK SENSOR	29
11.0	EXTERIOR DRIVER TRAFFIC LIGHT	30
11.1	EXTERIOR DRIVER WARNING SIGN	31
11.2	EXTERIOR OPERATING INSTRUCTION PLACARD	32
11.3	INTERIOR OPERATING INSTRUCTION PLACARD	33
12.0	TROUBLESHOOTING	34
13.0	WIRING DIAGRAMS	35
13.1	BLUE GENIUS GOLD	35

1.0 ABOUT THE INTERLOCK CHOCK

The Blue Giant Interlock Chock Wheel Equipment is a high performance system. The Interlock Chock provides wheel chocking options when a facility must handle a variety of trailer or vehicle needs.

An interior and exterior lights communication system keeps truck drivers and warehouse personnel advised of safety conditions during dock operations.

1.1 OWNER'S PURCHASE RECORD

Please record information for future inquiries and to validate warranty. See "2.1 WARRANTY INFORMATION" on page 6.

Dealer:	Date in Service:
	Number of Units:
Serial Number:	Door #:
Serial Number:	Door #:
Serial Number:	Door #:
Serial Number:	Door #:
Serial Number:	Door #:
Serial Number:	Door #:
Serial Number:	Door #:
Serial Number:	Door #:
Serial Number:	Door #:
Serial Number:	Door #:

The manufacturer offers a full line of chocks, dock levelers, dock safety equipment, accessories, ergonomic equipment, scissor lift equipment, seals and shelters, and industrial trucks. Concurrent with a continuing product improvement program, specifications are subject to change without notice (See "2.1 WARRANTY INFORMATION" on page 6). Please contact the your Blue Giant Dealer for latest information. Some features illustrated may be optional in certain market areas.

2.0 INTRODUCTION

The following is a quick reference to important procedures that must be followed while using the Interlock Chock. It is not intended to cover, or suggest that it does cover, all procedures necessary to ensure safe operation. All operators should be aware of and abide by all workplace safety regulations applicable to the operation of the Interlock Chock. These laws and regulations include but are not limited to:

- The Occupational Safety and Health Act
- Canada Occupational Health and Safety Regulations
- Occupational Safety and Health Acts for Individual States (USA), Provinces, or Territories

For additional information on these regulations as well as industry standards that may apply to this product, please contact:

American National Standards Institute (ANSI)
1430 Broadway
New York, NY 10018
Telephone: 212.642.4900
www.ansi.org



Loading Dock Equipment Manufacturers
A Product Section of Material Handling Industry of America
A Division of Material Handling Industry
8720 Red Oak Blvd, Suite 201
Charlotte, NC, 28217-3992
Telephone: 704.676.1190
www.mhi.org/lodem



2.1 WARRANTY INFORMATION

Thank you for purchasing Blue Giant products. We appreciate your business, and are confident that our product will serve you for many years to come. In the event that you experience a problem with our product, our Customer Support Team is here to support the Blue Giant Product(s) that you have purchased.

To validate warranty on recently purchased equipment, please complete and submit your information with our on-line Warranty Registration at www.BlueGiant.com.

For more information about Blue Giant Warranty Support, please contact your Blue Giant Dealer. You may also visit www.BlueGiant.com or phone 1.905.457.3900.

NOTE: All products must be registered to qualify for warranty.

DEALER INFORMATION

Name:

Contact:

Telephone:

2.2 EXCLUSION OF LIABILITY

The manufacturer assumes no liability for damage or injury to persons or property which occur as a result of defects or faults in or incorrect use of the Interlock Chock. The manufacturer assumes no liability for lost profits, operating downtimes, or similar indirect losses incurred by the purchaser. Injury to third parties, irrespective of its nature, is not subject to compensation.

The manufacturer reserves the right to make changes at any time to the modules, components, and accessories, concurrent with its continuing product improvements and development program. Specifications, operating instructions, and illustrations included in this manual are subject to change without notice. Please contact manufacturer for the latest information. Please see “2.4 OWNER'S RESPONSIBILITY” on page 7.

2.3 MANUFACTURER'S NOTE

The Interlock Chock has been carefully inspected and tested at the manufacturer's plant prior to shipment, but it **MUST be checked** upon receipt for transport damage. Any observed transport damage is to be listed on the signed copy of the freight document. There are many configurations or custom designs whose specifications may not be fully reflected in this manual. Contact your Blue Giant Dealer to obtain the General Arrangement drawing for application specific designs.

Notify the freight forwarder, Blue Giant, and the dealer of any damage WITHIN 24 HOURS.

2.4 OWNER'S RESPONSIBILITY

The Interlock Chock needs to be maintained and inspected by the owner to verify its safe condition for operation.

1. The owner should recognize the inherent danger of the interface between the Interlock Chock and the freight carrier. The owner should, therefore, train and instruct operators in the safe use of the Interlock Chock and accessories in accordance with the manufacturer's recommendations.
2. The owner should thoroughly familiarize themselves with the following procedures and specifications as referenced in this manual, and request immediate replacement of all manufacturer-supplied documents that are missing, damaged, or otherwise illegible.
Owners shall apply sound principles of safety, training, inspection, maintenance, and expected operating environment toward their Interlock Chock usage and maintenance requirements.
 - Commissioning instructions
 - Operating instructions
 - Daily maintenance procedures checklist
 - Inspections procedures
 - Recommended spare parts listsUpon receipt of any newly purchased Interlock Chock, the owner shall verify the presence of owner's manuals, operating placards, and any other documentation necessary for training dock personnel how to use the equipment safely and effectively.
3. All Blue Giant Interlock Chock shall undergo regularly scheduled planned maintenance. Maintenance requirements will vary according to usage frequency and application, so the owner shall contact with their authorized Blue Giant distributor for schedule recommendation. Written records of the performance of these procedures shall be kept as per warranty requirements and per local state or provincial requirements. Please see “7.0 MAINTENANCE” on page 17.
4. Interlock Chock that is structurally damaged, experiencing performance irregularities, or has been potentially compromised shall be removed from service until a trained and authorized manufacturer's representative can conduct an inspection and perform any necessary repairs.
5. As with any piece of machinery, Interlock Chock requires routine maintenance, lubrication, and adjustments. Recommended procedures are itemized in the Planned Maintenance Program (PMP) checklist included in installation and technical manuals. It is recommended that for anything other than the basic maintenance procedures outlined in this manual, please contact your Blue Giant Dealer.
6. The owner shall ensure that all nameplates and safety labels are in place and legible, and that the appropriate manuals are provided to authorized users. Replacement nameplates, safety labels, and manuals are available through the Blue Giant Aftermarket Department.
7. The owner or a trained and authorized representative shall verify that all freight carrier brakes have been applied and a vehicle restraint and/or wheel chocks properly engaged before cross-docking procedures begin. For safety reasons, trailers must be held securely in place to avoid accidental separation from the Interlock Chock.
8. Unless specifically agreed to in writing by Blue Giant Equipment Corporation at the time of order (and prior to manufacture), all Blue Giant Interlock Chock is sold as a complete offering and must not be altered or added to in any manner (which includes configuration and function) without written permission from an authorized manufacturer's representative. These changes shall also satisfy all safety recommendations of the original equipment manufacturer for the particular application of the Interlock Chock.

9. If, at the request of the owner, Blue Giant does not supply all or some of the Interlock Chock power unit and/or control panel components, the owner shall assume responsibility for any and all operational and safety issues associated with the resulting configuration.
10. The owner must adhere to the load classification information provided on the product nameplate. Failure to do so will void product warranty and can result in serious injury, including death.
11. Operational placards must be visible from equipment location and permanently attached to a wall or structure.
12. The owner shall ensure that inspections are performed to the lifting device as prescribed by law or regulation.

3.0 SAFETY MESSAGE COLOR IDENTIFICATION

This manual includes color-coded safety messages that clarify instructions and specify areas where potential hazard exists. To reduce the possibility of equipment damage and serious injury or death, please follow the instructions and understand the warnings contained in the messages. If warning decals become damaged or missing, replace them immediately. Avoid accidents by recognizing dangerous procedures or situations before they occur.

DANGER

Serious injury or death will likely occur if the instructions are not followed.

WARNING

Serious injury or death may occur if the instructions are not followed.

CAUTION

Instructions marked caution concern safe operating procedure. Failure to comply may result in personal injury.

NOTICE

Procedures marked notice must be followed in order to reduce damage to machinery.

3.1 OPERATIONAL SAFETY WARNINGS

These are safety warnings that may be part of a procedure or hardware warning decal.

DANGER

- BEFORE BEGINNING ANY SERVICE PROCEDURES:
 - Disconnect the power and follow all lockout / tagout procedures, as per OSHA requirements. Refer to wiring diagrams.
- Installation must be performed only by trained and authorized personnel.
- Prior to installation, place adequate barriers to prevent vehicle traffic from entering the work area.
- During installation, anchors must be properly torqued to achieve the necessary anchoring strength. **DO NOT USE IMPACT DRIVERS.**
- Any electrical work must be performed by qualified personnel only.
- Do not remove the wheel chocks until loading /unloading is finished and the truck is cleared for departure and the lights have changed to RED inside and GREEN outside.

WARNING

- Do not ground welding equipment to any electrical components.
- Do not allow the drill to go too deeply into the control box, as damage may occur to the control systems.
- Never use air to blow debris from the control box. Use a vacuum to perform any necessary cleaning.
- Do not connect green ground lead into control box or junction box until all welding has been completed.
- Improper adjustments may cause operational problems with equipment.

CAUTION

- Only trained personnel should operate or service this equipment.
- Do not operate the Interlock Chock until the transport vehicle is parked against the dock bumpers.
- Always park the Interlock Chock after use.
- Conduct routine inspections and maintenance. Failure to do so could cause equipment damage and or personal injury.
- Always call your authorized service representative or manufacturer immediately if a malfunction occurs.

NOTICE

- Do not ground welding equipment to any electrical components.
- Do not allow the drill to go too deeply when drilling holes in the control box. Damage to the control systems may occur.
- Never use air to blow debris from control box. Use a vacuum to remove debris from control box.
- Do not connect green ground lead into control box until all welding has been completed.
- Always keep the work area clean and free of litter.
- Always clean all side openings of dirt and debris.
- Always clean up dry and liquid spills immediately after they occur.
- Always maintain proper lighting in the work area.
- If a procedure is not clearly defined in this manual, contact your Blue Giant Dealer.

4.0 LOCKOUT / TAGOUT PROCEDURE AND RULES

In accordance with the rules and regulations of the Occupational Safety and Health Administration (OSHA) and/or local jurisdiction, all affected employees must be notified that the machine or equipment will be shut down and locked out to perform repair or maintenance work.

The work area must be checked to verify that all personnel have been removed or safely repositioned.

The machine or equipment power supply shall be locked in the **OFF** position or disconnected from the energy source.

Blue Giant strongly recommends that only OSHA-approved and/or local jurisdiction lockout devices and procedures be utilized.

The energy isolating device must bear a prominent warning tag indicating that work is being done on the equipment and the name of the authorized employee responsible for the lockout.

It is mandatory that tagout notices shall **NOT** be susceptible to deterioration or illegibility due to weather conditions, exposure to chemicals and/or moisture.

WARNING

Always lockout and tagout any power source before performing any work on any electrical devices or electrical controls according to OSHA regulations and approved local electrical codes. Refer to wiring diagrams.

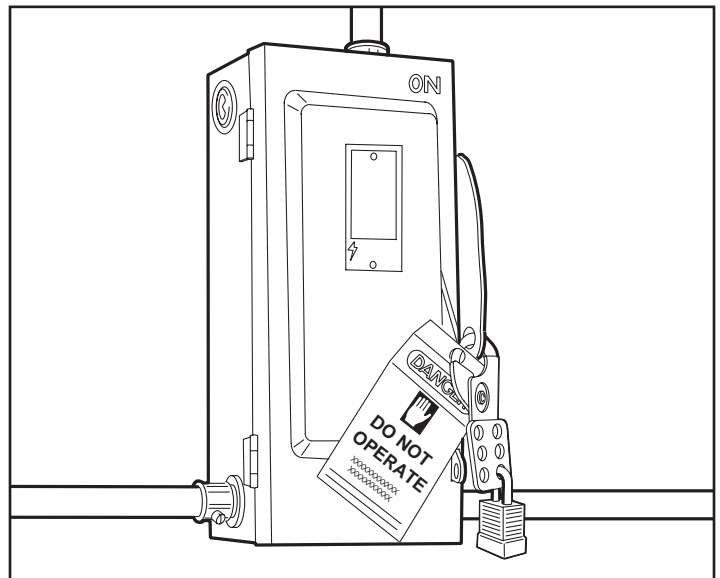

An example of lockout / tagout. Verify and comply with local codes/ regulatory requirements.

4.1 ELECTROSTATIC SENSITIVE DEVICE PROTECTION POLICY

This policy applies to static sensitive electronic products primarily printed circuit boards (PCBs) and sensors. Switches, relay, lamps and wire are not sensitive and do not apply.

If welding near ESD components, correctly protect and ground all necessary equipment.



1. Prior to handling PCBs, wear a static grounding wrist strap and clip it to an electrical ground. The metal plate on the inside of the wristband must be in contact with the wearers skin.
2. PCBs should never be handed to other personnel or set down anywhere.
3. Place PCBs in black ESD shielding bags for return or storage. Only one PCB or sensor should be placed in a static bag. Attach paperwork and other items to the outside with adhesive pouches or elastic bands.
4. The control boxes protect the PCBs inside from static, and should not be used to store manuals or other accessories.

5.0 INDEPENDENT TYPE CONTROL STATION

Depending on the specific installation, the control station may be mounted on an adjacent wall. See "6.0 OPERATING INSTRUCTIONS" on page 15 for more information.

5.1 PUSH BUTTON CONTROLS

Controls one individual vehicle Interlock Chock only, equipped with touch buttons, inside forklift operator traffic lights, operator menu screen, and keypad for coded features.

Controls one individual vehicle wheel chock only, equipped with touch buttons, inside forklift operator traffic lights, operator menu screen, and keypad for coded features.

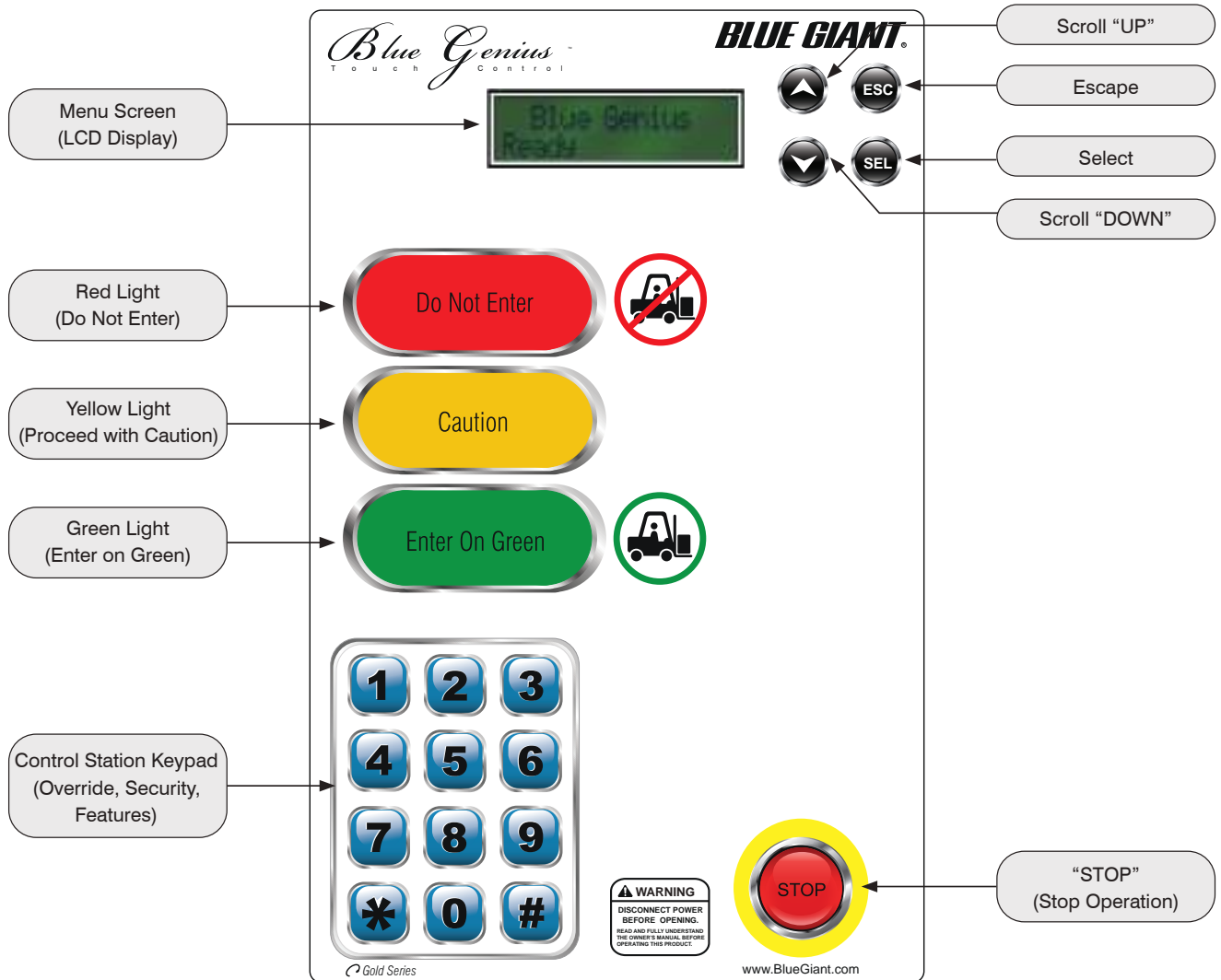

NOTE: Typical decal shown, actual decal is bilingual.

5.2 BUTTON FUNCTION

When touching any of the function buttons or keypad, use the ball of the finger.

Pressure not required to operate buttons. The control station's unique touch sensors detect the proximity of the dock operator's finger.

Restraint control buttons are momentary contact: a single touch will activate the engage or release features.

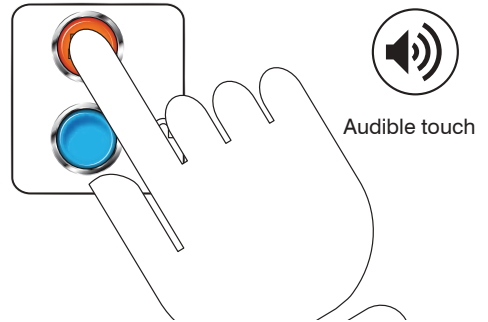

6.0 OPERATING INSTRUCTIONS

Follow the safe operating instructions to ensure personnel, load, and equipment safety.

WARNING

- Do not operate the Interlock Chock unless you have been trained and authorized to do so, and have read and understood all of the safety information and instructions contained in this manual.
- Do not operate this wheel chock until you have checked its condition. Report the need for repairs to your supervisor immediately and do not operate the unit until repairs are made.
- It is the responsibility of the owner / operator of truck / vehicle to (whenever possible) exhaust the air from air-ride suspension systems prior to performing loading or unloading.

6.1 PLACE WHEEL CHOCK

Standard and end loading follow the same procedure.

1. Once the vehicle driver has placed the Interlock Chock, the Blue Genius Control Panel flashes AMBER.

Fully open the dock door.

While the door is opening, Blue Genius Control Panel will illuminate solid RED.
When the door is fully open, the Blue Genius Control Panel remains solid RED.

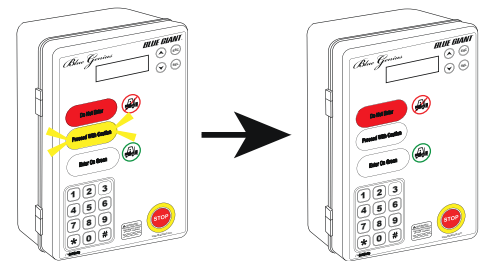

2. Deploy dock.

While dock deploying, Blue Genius Control Panel illuminates solid RED.

When dock fully deployed, Blue Genius Control Panel illuminates solid Green.

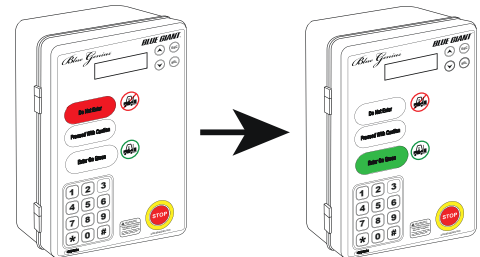
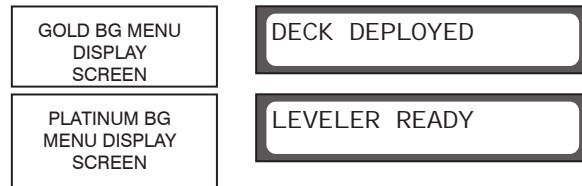

3. Proceed with loading or unloading.

6.2 REMOVE WHEEL CHOCK

Loading or unloading is complete. The driver is getting ready to depart.

1. When loading or unloading is completed, restore dock to fully parked position.
When the dock leaves the deployed position and is parked, Blue Genius Control Panel illuminates solid RED.

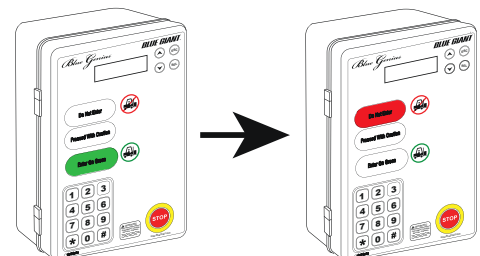
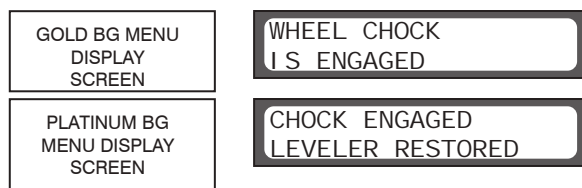

- Close door completely.
Blue Genius Control Panel illuminates solid RED.

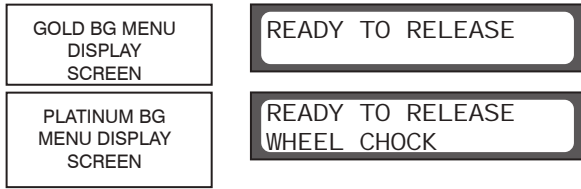

- As driver restores chock, Blue Genius Control Panel illuminates solid RED.

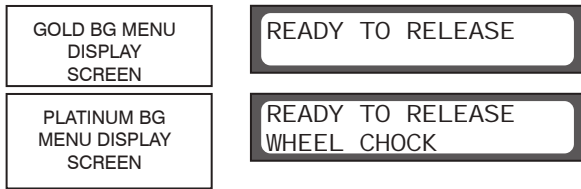

- Chock is back in cradle.
Blue Genius Control Panel remains solid RED.



7.0 MAINTENANCE

Develop a planned or scheduled maintenance plan to keep the Interlock Chock in good operating order.

WARNING

- Do not attempt to install, make repairs, or adjustments. Only a trained and authorized service technician should perform the installation process, make repairs, or make adjustments. Contact your Blue Giant Dealer for assistance.
- Do not service this equipment until you have read and understood all of the safety information and instructions contained herein. Failure to adhere to recommended safety practices in this manual and on the Interlock Chock warning labels could result in death or serious injury.
- Do not conduct maintenance or repairs until adequate barriers have been placed to keep warehouse and vehicle traffic away from the work area.
- Before doing any electrical work, verify that the power is disconnected and properly tagged or locked out.

7.1 PLANNED MAINTENANCE PROGRAM (PMP)

In addition to the Daily Maintenance Procedures (DMP), the manufacturer recommends (and local government regulations may require) that a Planned Maintenance Program (PMP) and safety inspection program be performed by a trained and authorized service technician on a regular basis to ensure the equipment is in safe operating condition. The PMP will provide an opportunity to make a thorough inspection of the safety and operating condition of the Interlock Chock. Necessary adjustments and repairs can be done during the PMP, which will increase the life of components and reduce unscheduled downtime.

Recommended procedures for a periodic planned maintenance program that covers inspections, operational checks, cleaning, and minor adjustments are outlined in the Owner's Manual for this product. Contact your Blue Giant Dealer regarding for assistance with a planned maintenance program by offering trained service personnel with expertise in Interlock Chock maintenance requirements.

7.2 OPERATOR DAILY INSPECTION

The Interlock Chock shall always be examined by the operator **PRIOR TO ANY USE** to verify that it is safe to operate.

The manufacturer recommends scanning to storage or making multiple photocopies of the DMP Checklist. The operator should fill out this form to keep a daily record of operation and maintenance issues. See "7.6 DAILY MAINTENANCE PROCEDURES (DMP) CHECKLIST" on page 18.

7.3 ROUTINE SERVICING AND MAINTENANCE

Regular maintenance and care of the Interlock Chock is very important for operator safety, operation efficiency, and cost. A faulty Interlock Chock is a potential source of danger to the operator, and to other personnel working near it. As with all quality equipment, keep the Interlock Chock in good operating condition by following the recommended schedule of maintenance. Failure to properly maintain or operate the Interlock Chock can void the manufacturer warranty.

7.4 PLANNED MAINTENANCE PROGRAM INTERVALS

Arrange for a qualified Interlock Chock repair technician to perform regularly scheduled planned maintenance on your Interlock Chock every three months for single shift operations or monthly for multi-shift operations. Please contact your Blue Giant Dealer for further details.

7.5 MAINTENANCE SEQUENCE

Follow this procedure for maintenance of the Interlock Chock .

1. Cleaning, including in pit area.
2. Visual inspection of all components.
3. Test operate all functions.
4. Adjustments, if required (by a trained service technician only).
5. If installed, check for missing or damaged dock bumpers.
6. Record inspection details and findings for owners' files.

7.6 DAILY MAINTENANCE PROCEDURES (DMP) CHECKLIST

Use checklist to aid the daily maintenance inspection. Photocopy or scan to storage then print from stored copy as needed.

⚠️ DANGER

- When repairing or conducting maintenance procedures on electrical components, perform lockout / tagout steps according to OSHA regulations and approved electrical codes.
- Prior to inspection, place adequate barriers to reduce unauthorized personnel and vehicle traffic from entering the work area.

⚠️ CAUTION

- All repairs and maintenance work are to be conducted by trained and authorized personnel ONLY.

INSPECTED BY: _____ DATE: _____

SERIAL #: _____ DOOR #: _____

Forward this checklist to the person responsible for Interlock Chock maintenance. See "Owner's Purchase Record" for Date in Service.

INSTRUCTIONS: Indicate "OK for USE" with a check mark ✓ in the appropriate box of each inspection point. Indicate "NOT OK for USE" with an x in the appropriate box of each inspection point.

EVERY DAY (MAY BE PERFORMED BY OWNER OR ATTENDANT):

- Remove any debris that may have accumulated around the Interlock Chock .
- Verify complication-free operation of the Interlock Chock , and the interior / exterior lights system (if installed).
- Verify that outside and inside signage is present and legible (if equipped).
- Remove any potential trip hazards from around the dock area.
- Verify that dock bumpers/risers/extensions are in working condition (if equipped).
- Check curb angles for irregularities (e.g. concrete cracks).
- Verify that the overhead door is functioning correctly (if equipped).
- Verify that instructional caution and danger labels are present and legible on the product. Replace if necessary.
- Verify that a second standard vehicle wheel chock is present and in working condition (if equipped).
- Verify complication free operation of the equipment through a complete cycle (refer to Operation Placard).
- _____
- _____

SCAN TO STORAGE OR PHOTOCOPY THIS CHECKLIST AND FILL OUT REGULARLY FOR YOUR RECORDS.

Explain faults briefly in the space provided below:

8.0 RECOMMENDED SPARE PARTS

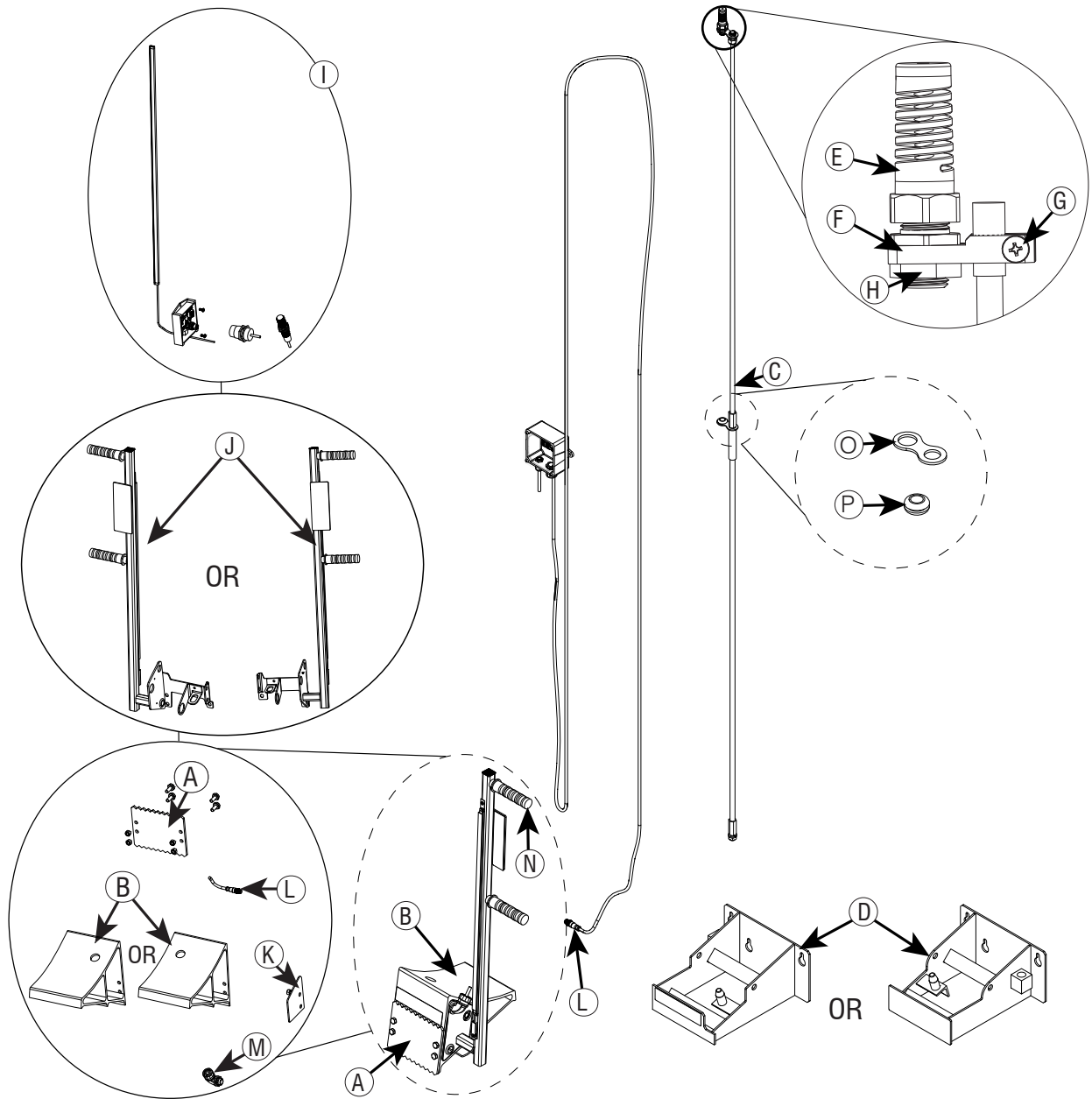

STANDARD OPERATIONAL COMPONENTS

ITEM	PART #	DESCRIPTION	QTY REQ'D
A	2009848	Toothed Flange	1
B	2012832	Chock - Machined (Left Hand Drive)	1
	2012832-1	Chock - Machined (Right Hand Drive)	
C	012-703	Whip	1
D	2014943	Cradle (Left Hand Drive)	1
	2014943-1	Cradle (Right Hand Drive)	
E	012-702	Flex Strain Relief Connector	1
F	2016909	Cable Clamp	1
G	011-205	Headscrew #10-24, 7/8in. long	1

STANDARD OPERATIONAL COMPONENTS			
ITEM	PART #	DESCRIPTION	QTY REQ'D
H	025-200	3/8 (-18) NPT Metal Locknut	2
I	BGRM001-ITC485	I/O Board, LED board, and Sensors (Left Hand Drive)	1
	BGRM001-ITC485-1	I/O Board, LED board, and Sensors (Right Hand Drive)	
J	2015410	I/O Module with Handle Weldment (Left Hand Drive)	1
	2015410-2	I/O Module with Handle Weldment (Right Hand Drive)	
K	2015246	Side Cover	1
L	026-M12-M6HD	Cable, M12-4, 6M, Male leads	1
M	025-005	CONNECTOR 1/2" CORD GRIP - 90 DEGREE	1
N	012-700	VINYL PLASTIC ROUND GRIPS	2
O	2016853	CABLE HOLDER	1
P	012-406	GROMMET RUBBER	1

9.0 DECAL IDENTIFICATION AND LOCATION

These labels inform operators and personnel about hazardous areas on and around the Interlock Chock. Left hand drive version shown. Locations applicable for either left or right hand drive.



(A)



(D)



(B)



(E)



(C)



(F)

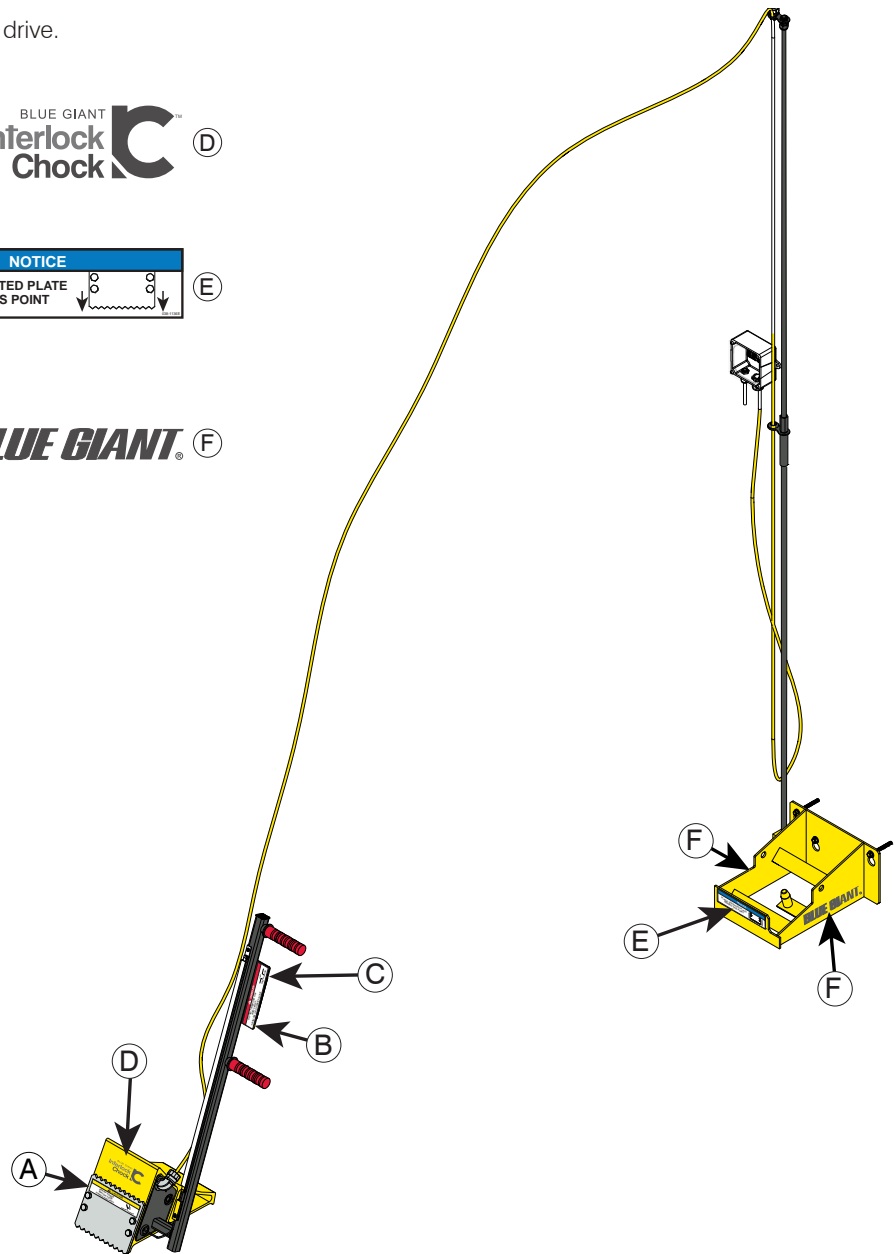

ITEM	QTY	PART #	DESCRIPTION
A	1	038-1135E	Caution Sharp Hazard Decal
B	1	038-1137E	Danger Chock Decal
C	2	038-1134EF	Serial Plate Decal
D	1	038-1140E	Interlock Chock logo
E	1	038-1136E	Notice Cradle Placement Decal
F	2	038-1141E	Blue Giant Logo

9.1 OPERATION PLACARDS

The Operating Instruction Placard (Part. No. 038-1124E) is to be wall mounted near the dock lift controls.

The Exterior Operating Instruction Placard (Part. No. 038-1139E/F) is to be wall mounted near the External Traffic Lights.

Duplicates of 038-1139E and 038-1124E provided on the following pages. (Not to scale).

OPERATING INSTRUCTIONS

Only for the Blue Giant Interlock Chock™

A

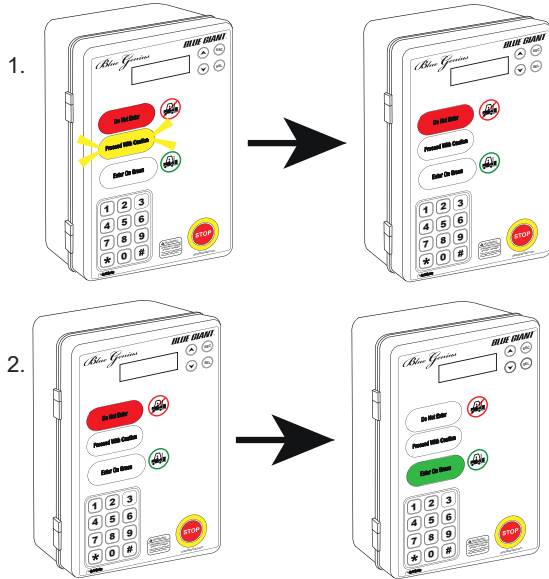

PLACE WHEEL CHOCK

Standard and end loading follow the same procedure. Once the vehicle driver has placed the Interlock Chock, the Blue Genius Control Panel flashes AMBER.

1. Fully open the dock door.
While the door is opening, Blue Genius Control Panel will illuminate solid RED.
When the door is fully open, the Blue Genius Control Panel remains solid RED.

GOLD OR PLATINUM BG MENU DISPLAY SCREEN

READY TO RAISE DECK

2. Deploy dock.
While dock deploying, Blue Genius Control Panel illuminates solid RED.
When dock fully deployed, Blue Genius Control Panel illuminates solid Green.

GOLD BG MENU DISPLAY SCREEN

DECK DEPLOYED

PLATINUM BG MENU DISPLAY SCREEN

LEVELER READY

3. Proceed with loading or unloading.

B

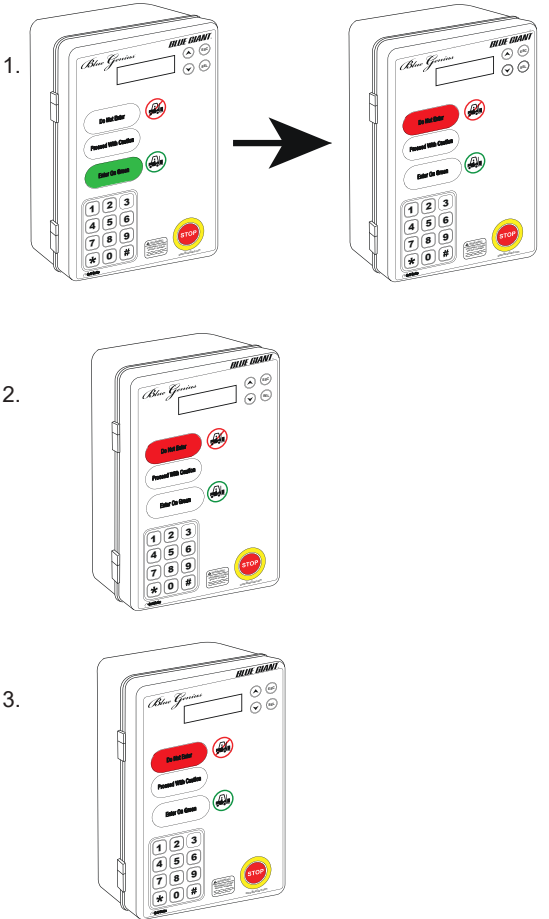

REMOVE WHEEL CHOCK

1. When loading or unloading is completed, restore dock to fully parked position.
When the dock leaves the deployed position and is parked, Blue Genius Control Panel illuminates solid RED.

GOLD BG MENU DISPLAY SCREEN

WHEEL CHOCK IS ENGAGED

PLATINUM BG MENU DISPLAY SCREEN

CHOCK ENGAGED LEVELER RESTORED

2. Close door completely.
Blue Genius Control Panel illuminates solid RED.

GOLD BG MENU DISPLAY SCREEN

READY TO RELEASE

PLATINUM BG MENU DISPLAY SCREEN

READY TO RELEASE WHEEL CHOCK

3. As driver restores chock, Blue Genius Control Panel illuminates solid RED.

GOLD BG MENU DISPLAY SCREEN

RESTORE WHEEL CHOCK

PLATINUM BG MENU DISPLAY SCREEN

READY TO RELEASE WHEEL CHOCK

4. Chock is back in cradle.
Blue Genius Control Panel remains solid RED.

GOLD OR PLATINUM BG MENU DISPLAY SCREEN

BLUE GENI US READY

MANDATORY

**WHEELS
MUST BE
CHOCKED**



WARNING

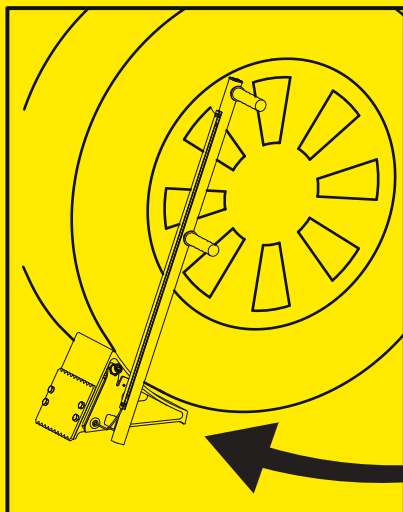

**IF ALARM
SOUNDS AND
WHEEL CHOCK
FLASHES RED
ENSURE CHOCK
IS ENGAGED**

BLUE GIANT. 038-1139E

10.0 EQUIPMENT COMPONENT ILLUSTRATIONS

This section displays the various hardware components.

10.1 COMPONENTS AS SHIPPED CHECKLIST

This section displays the shipped hardware components.

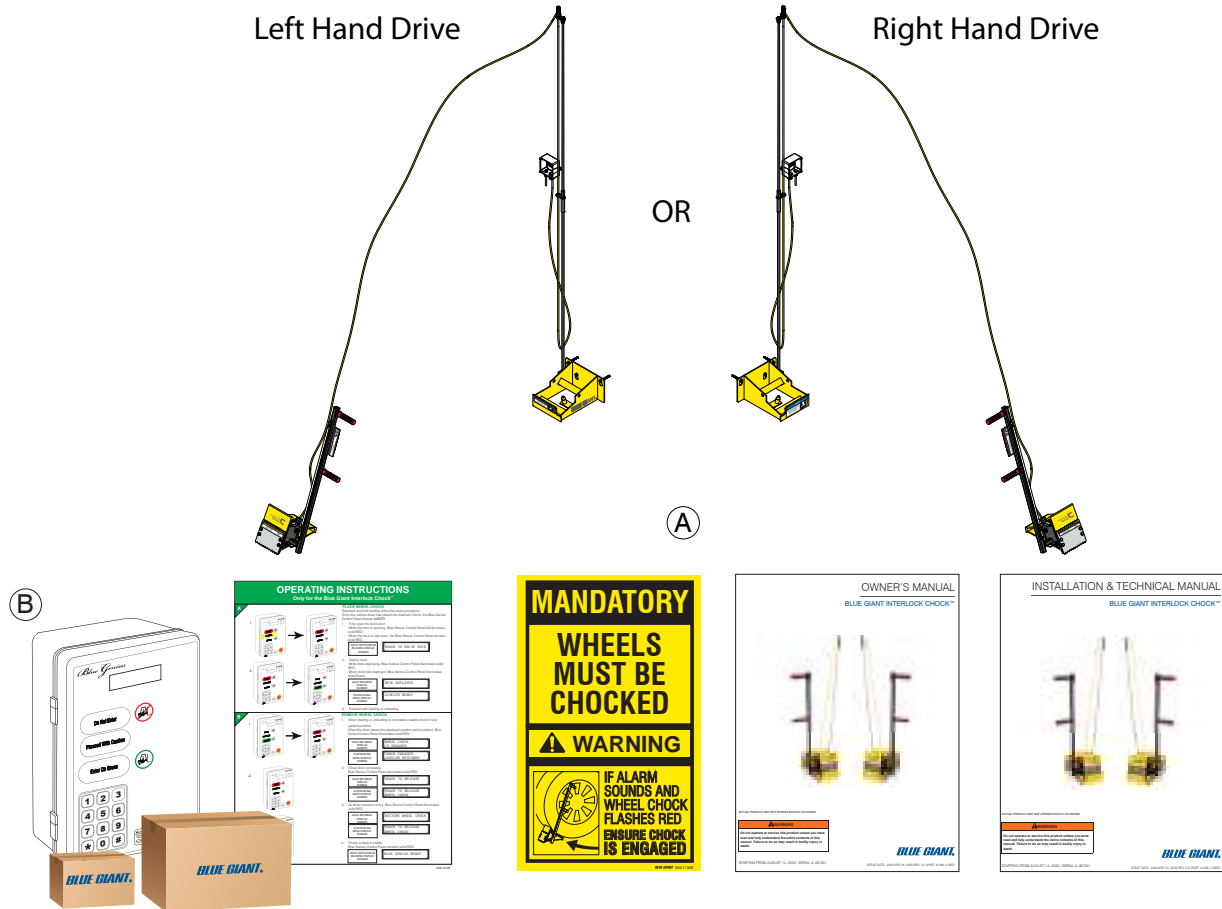

✓	ITEM	QTY.	PART NO.	DESCRIPTION	APPROX. WEIGHT
	A	1		Interlock Chock (Left or Right Hand Drive version)	—

Item B - CONTROL AND COMPONENTS INCLUDED:

✓	QTY.	PART NO.	DESCRIPTION	APPROX. WEIGHT
	1	—	Complete Control Assembly	6.2 lb 2.81 kg
	2	028-201	Door Sensors	— —
	1	25008304	Lip Sensor	— —
	1	038-1124E	Interlock Chock Interior Operating Instructions Placard	— —
	1	038-1139	E Interlock Chock Exterior Operating Instructions Placard F	— —
	1	038-1125EI	Installation Manual	— —
	1	038-1125E	Owner's Manual	— —
	1	038-1125EPL	Interlock Chock Parts List	— —
	1	032-806	Exterior Traffic Light	1.3 lb 0.6 kg
	1	038-225	E Exterior Driver Warning Sign F S	0.7 lb 0.32 kg

10.2 GENERAL DIMENSIONS

This section describes the length and height of the Interlock Chock components. Left hand drive shown. Measurement are the same for either hand drive.

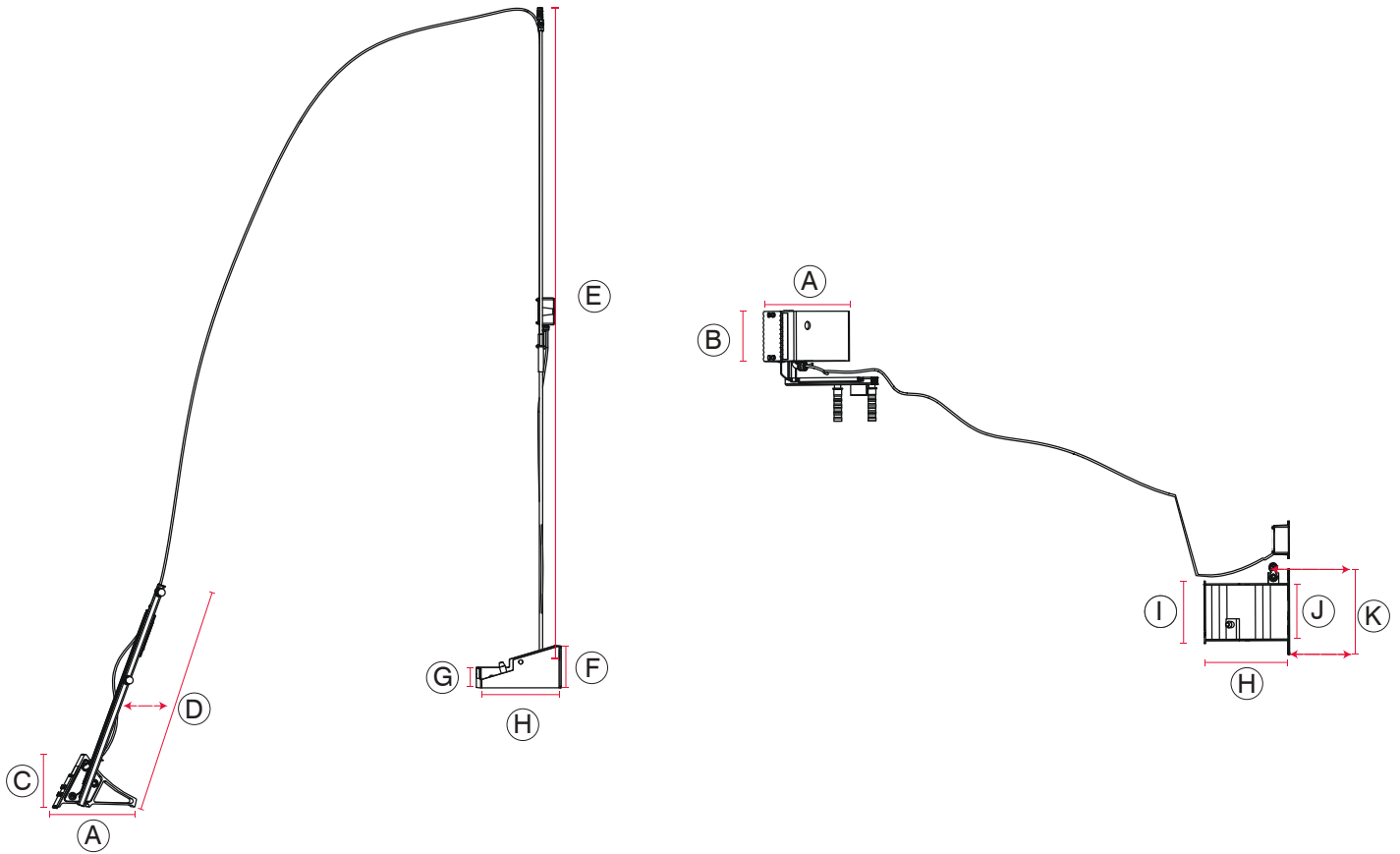

ITEM	DESCRIPTION
A	11 3/4in. (298 mm)
B	7in. (178 mm)
C	7 7/8in. (200 mm)
D	33 9/32in (845 mm)
E	100 3/4in. (2559 mm)
F	6 1/4in. (159 mm)
G	1 13/16in. (46 mm)
H	12in. (305 mm)
I	8 3/4in. (222 mm)
J	7 13/16in. (198 mm)
K	12in. (305 mm)

Contact your Blue Giant Dealer, if you have questions.

10.3 CONTROLS

This section depicts the Blue Genius Control Panel.

NOTE: Actual product may not appear exactly as shown.

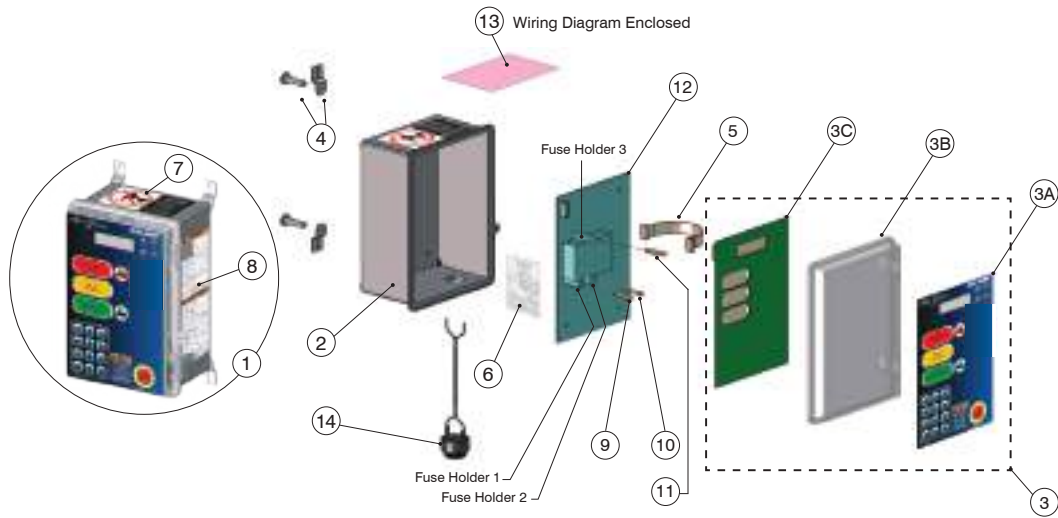

CONTROL ASSEMBLY			
ITEM	QTY	PART #	DESCRIPTION
1	1	BGG0H1115F	Complete Control Assembly, English / French
		BGG0H1115S	Complete Control Assembly, English / Spanish
2	1	025-G010-M	Control Box Enclosure (Includes 3B)
3	1	Consult Factory	Control Box Lid (3B) with Decal (3A) & Control / Board (3C) (Serial # Required)
3A	1	038-245EF	Button Decal, English / French
		038-245ES	Button Decal, English / Spanish
3B	1	025-G014-M	Cover Only
3C	1	026-G020-99	Blue Genius™ Control / Touch Board
4	4	025-G010-1	Mounting Tabs
5	1	026-G030	Ribbon Cable
6	1	038-284EF	Decal, Serial Plate English / French
		038-284ES	Decal, Serial Plate English / Spanish
7	1	038-283ESF	Decal, Do Not Drill
8	1	038-853EF	Warning Decal, English / French
		038-853ES	Warning Decal, English / Spanish
9	1	026-G104	Fuse, 250V, 0.75 Amp (Fast acting 1/4in. x 1-1/4in.)
10	1	026-G123	Fuse, 250V, 5 Amp (Time delay 1/4in. x 1-1/4in.)
11	1	026-237-1	Fuse, 250V, 2-1/2 Amp (Fast acting 1/4in. x 1-1/4in.)
12	1	Varies on Model	Blue Genius™ Power Board
13	1	026-615-1	Anti-Static Poly Bag (Wiring diagram enclosed - serial # required)
14	1	026-G402-B	Audible Speaker

10.4 JUNCTION BOX W/REMOTE I/O

This section depicts the junction box connecting the Blue Genius Control Panel to the wiring external to the building.

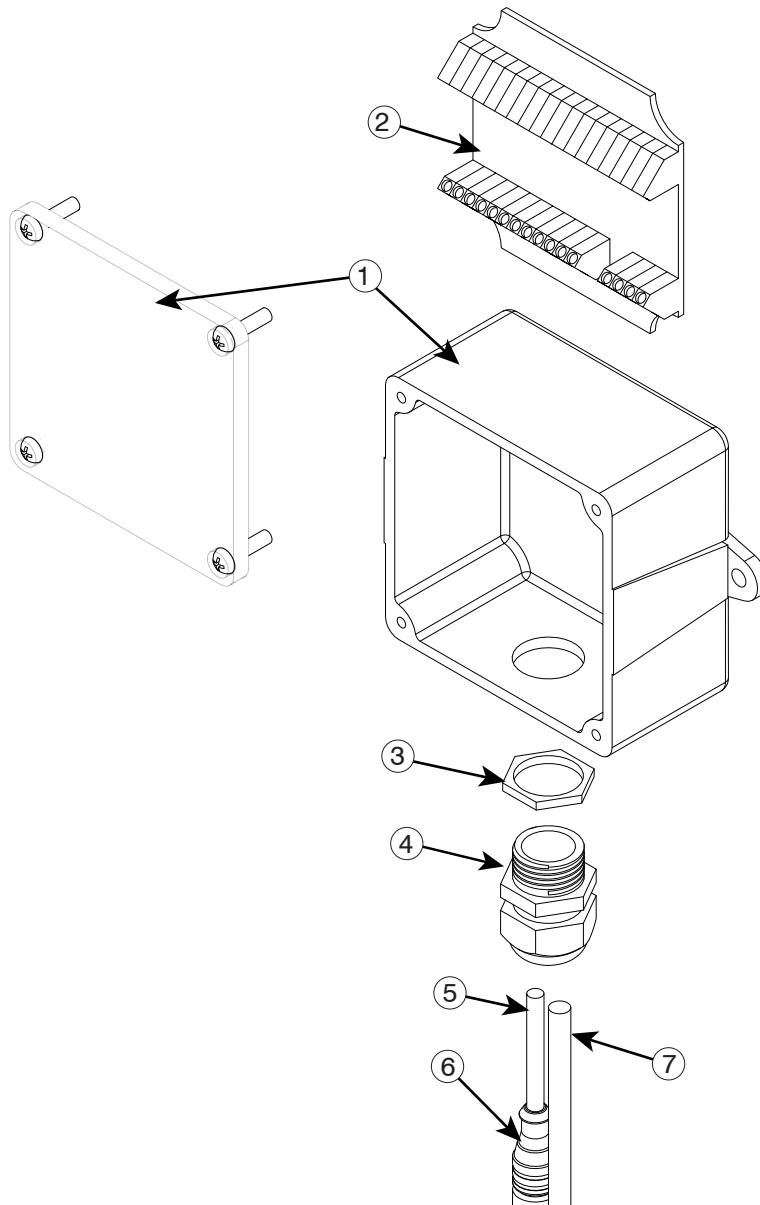

JUNCTION BOX ASSEMBLY			
ITEM	QTY	PART #	DESCRIPTION
1	1	025-G020-1R	Junction Box 4 x 4
2	1	026-G025BM	Remote I/O Board (Resistor)
3	1	025-177	PG16 Metal Locknut
4	1	025-174	PG16 Cable Gland
5	1	025-177	PG16 Multi-Hole Seal
6	1	026-H16-1	Com. Cable Shielded - 30 ft
7	1	026-M12-F5	7-Wire Cable (From Junction Box Assembly)

10.5 JUNCTION BOX ASSEMBLY

This section depicts the exterior junction box that connects the Interlock Chock and Exterior Traffic Lights to the wiring from the Blue Genius Control Panel

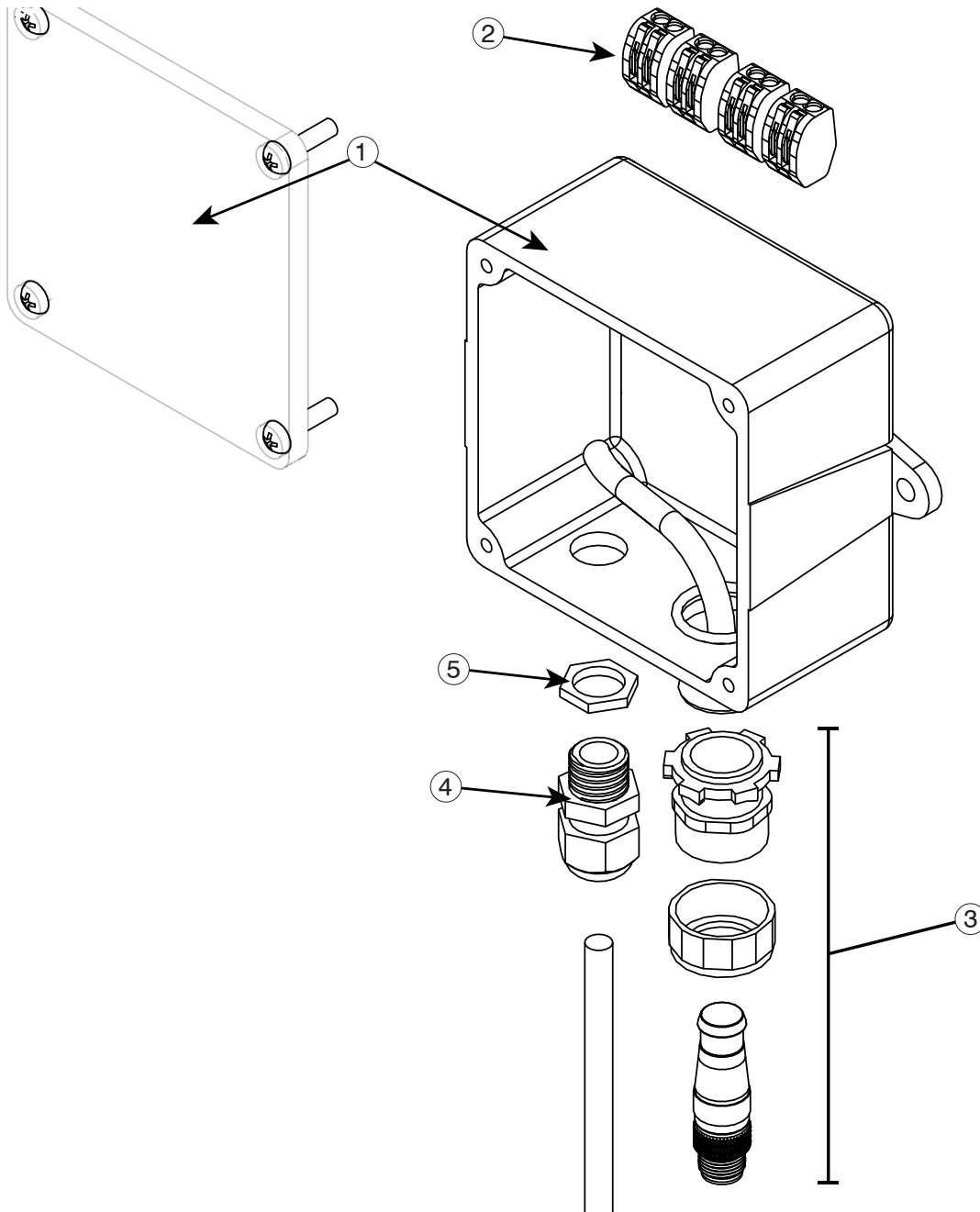

JUNCTION BOX ASSEMBLY			
ITEM #	QTY	PART #	DESCRIPTION
1	1	025-G020-1P	Junction Box 4 x 4
2	1	030-900-2	Terminal Blocks
3	1	025-016	Fitting SR-50-625 3/4in.
4	1	025-173	PG9 Cable Gland
5	1	025-176	PG9 Metal Locknut

10.6 DOCK INTERLOCK SENSOR

This section depicts the door interlock sensor and the mounting bracket.

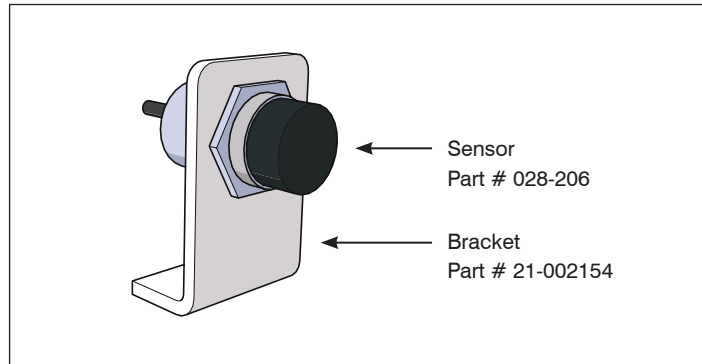

Dock interlock sensor (home/lip sensor).

The sensor ties the sequence of wheel chock to the dock leveler operation. Loading dock safety is improved with accurate operation sequence. Interior traffic light and wheel chock release operation relies on the interlock capability. It is mounted at parked position of any leveler.

11.0 EXTERIOR DRIVER TRAFFIC LIGHT

The exterior traffic lights improve loading dock safety.

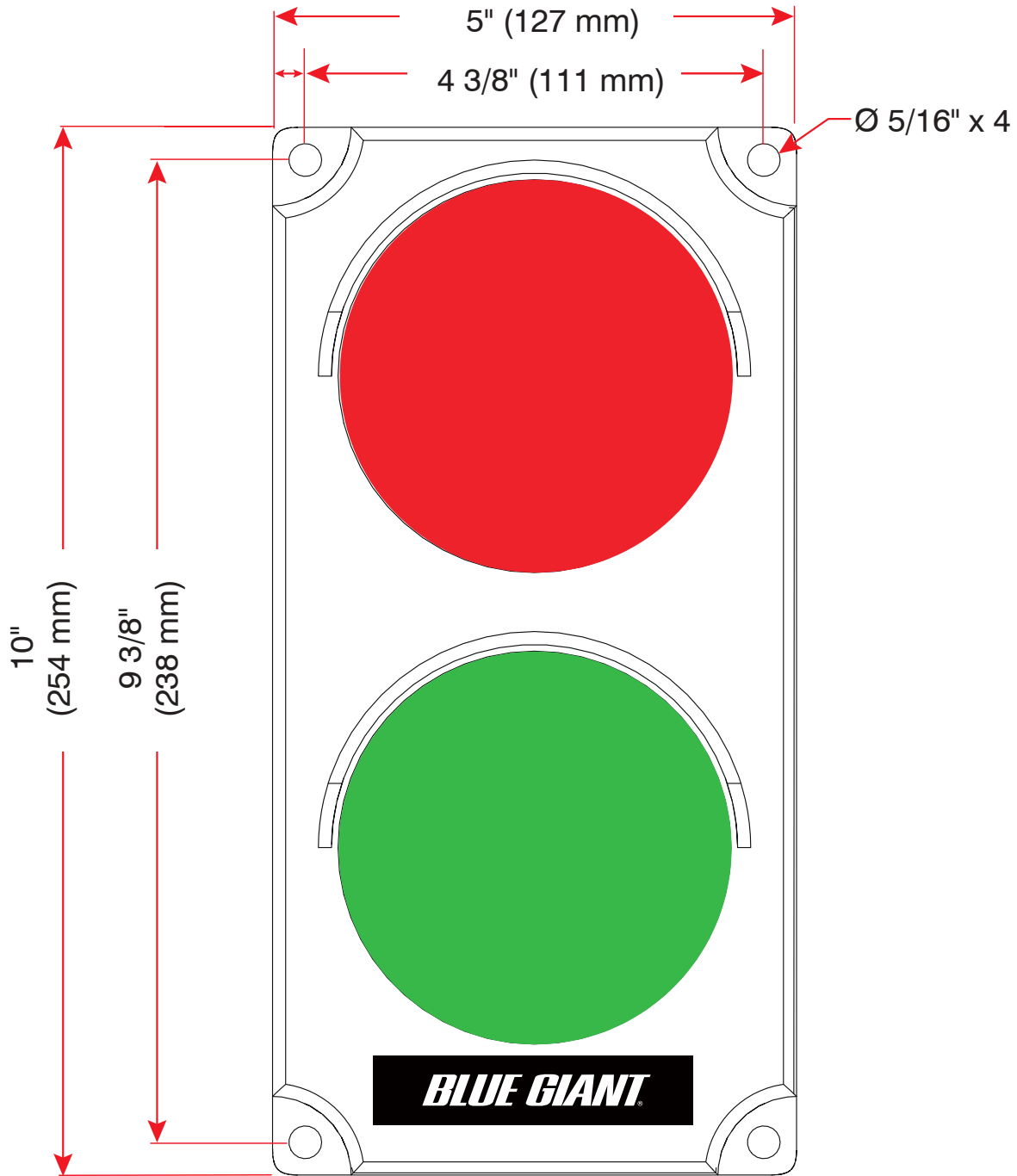

Exterior driver traffic light, part # 032-806.

11.1 EXTERIOR DRIVER WARNING SIGN

The exterior warning sign for drivers improves loading dock safety.



Exterior driver warning sign, part # 038-225
 (French 038-225F / Spanish 038-225S / Portuguese 038-225P)

11.2 EXTERIOR OPERATING INSTRUCTION PLACARD

The Exterior Operation Placard (part # 038-1139E/F) for outside dock workers or drivers.



11.3 INTERIOR OPERATING INSTRUCTION PLACARD

The interior operating instruction placard for inside dock workers.

OPERATING INSTRUCTIONS

Only for the Blue Giant InterLock Chock™

A

1.

2.

PLACE WHEEL CHOCK
Standard and end loading follow the same procedure. Once the vehicle driver has placed the Interlock Chock, the Blue Genius Control Panel flashes AMBER.

1. Fully open the dock door.
While the door is opening, Blue Genius Control Panel will illuminate solid RED.
When the door is fully open, the Blue Genius Control Panel remains solid RED.

GOLD OR PLATINUM BG MENU DISPLAY SCREEN	READY TO RAISE DECK
-----------------------------------------	---------------------

2. Deploy dock.
While dock deploying, Blue Genius Control Panel illuminates solid RED.
When dock fully deployed, Blue Genius Control Panel illuminates solid Green.

GOLD BG MENU DISPLAY SCREEN	DECK DEPLOYED
PLATINUM BG MENU DISPLAY SCREEN	LEVELER READY

3. Proceed with loading or unloading.

B

1.

2.

3.

REMOVE WHEEL CHOCK

1. When loading or unloading is completed, restore dock to fully parked position.
When the dock leaves the deployed position and is parked, Blue Genius Control Panel illuminates solid RED.

GOLD BG MENU DISPLAY SCREEN	WHEEL CHOCK IS ENGAGED
PLATINUM BG MENU DISPLAY SCREEN	CHOCK ENGAGED LEVELER RESTORED

2. Close door completely.
Blue Genius Control Panel illuminates solid RED.

GOLD BG MENU DISPLAY SCREEN	READY TO RELEASE
PLATINUM BG MENU DISPLAY SCREEN	READY TO RELEASE WHEEL CHOCK

3. As driver restores chock, Blue Genius Control Panel illuminates solid RED.

GOLD BG MENU DISPLAY SCREEN	RESTORE WHEEL CHOCK
PLATINUM BG MENU DISPLAY SCREEN	READY TO RELEASE WHEEL CHOCK

4. Chock is back in cradle.
Blue Genius Control Panel remains solid RED.

GOLD OR PLATINUM BG MENU DISPLAY SCREEN	BLUE GENI US READY
-----------------------------------------	--------------------

12.0 TROUBLESHOOTING

Use this section to help diagnose issues if the Interlock Chock is not operating as specified.

 **DANGER**

- Failure to properly secure the Interlock Chock deck prior to working underneath it may result in bodily injury, or death.

 **WARNING**

- Do not attempt to install, make repairs, or adjustments. Only a trained and authorized service technician should perform the installation process, make repairs, or make adjustments. Contact your Blue Giant Dealer for assistance.
- Do not service this equipment until you have read and understood all of the safety information and instructions contained herein. Failure to adhere to recommended safety practices in this manual and on the equipment warning labels could result in death or serious injury.
- Do not conduct maintenance or repairs until adequate barriers have been placed to keep warehouse and vehicle traffic away from the work area.
- Before doing any electrical work, verify that the power is disconnected and properly tagged or locked out, in accordance with OSHA regulations and approved electrical codes.

The following description of operating principles is intended as a guide when trouble shooting and making adjustments or repairs. If no fault can be found and equipment fails to operate properly, contact your Blue Giant Dealer.

PROBLEM	PROBLEM CAUSED
Wrong voltage	Check line voltage to nameplate voltage.
Motor connected to high voltage connection on lower voltage feed.	Check motor connection to nameplate.
Control fuse blown.	Replace.
Interlock devices issues.	Check all switches.
Shipping bolts not removed.	Remove and inspect unit.
Hydraulic hose pinched.	Check hose.
Wheel chock works but LED lights are not lit. LCD display is working.	Power source for lights is damaged. Replace control board.
Exterior traffic lights are dim, displaying incorrectly (wrong color) or malfunctioning (only one light works).	Check wiring to lights. Ensure that the red outside light is connected to terminal # 12 on the control strip label 1 to 14 and that the green light is connected to terminal #13 and the COM of the lights are connected to terminal #14. Lights COM wire is terminated in wng terminal (other than #14).

13.0 WIRING DIAGRAMS

NOTICE

The following wiring diagrams are sample configurations only. Wiring diagrams specific to your needs will be provided inside the control panel and/or as part of your submittal package.

13.1 BLUE GENIUS GOLD

NOTE: Refer to both wiring diagrams for the two door sensor wiring arrangements.

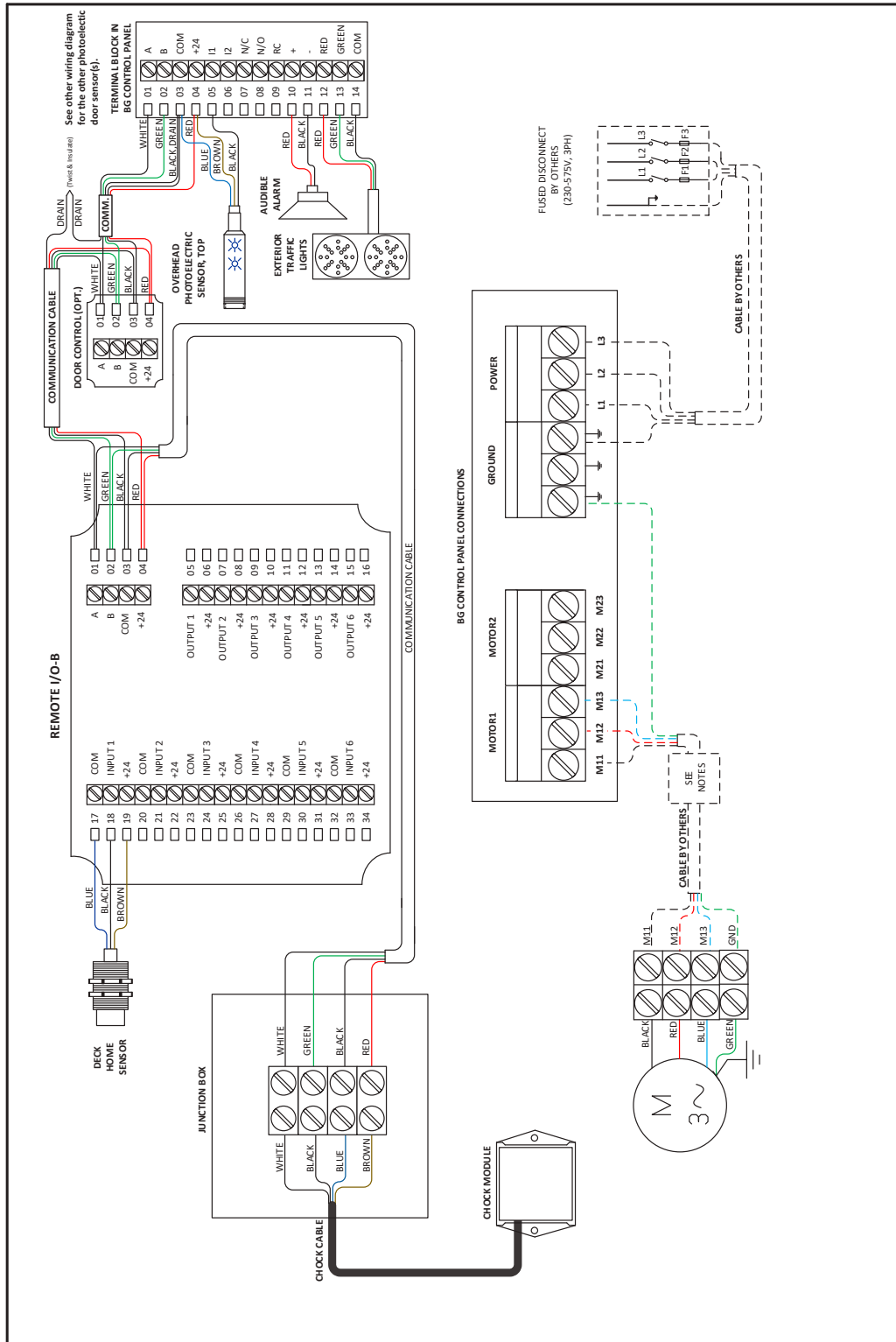

NOTE: Refer to both wiring diagrams for the two door sensor wiring arrangements.

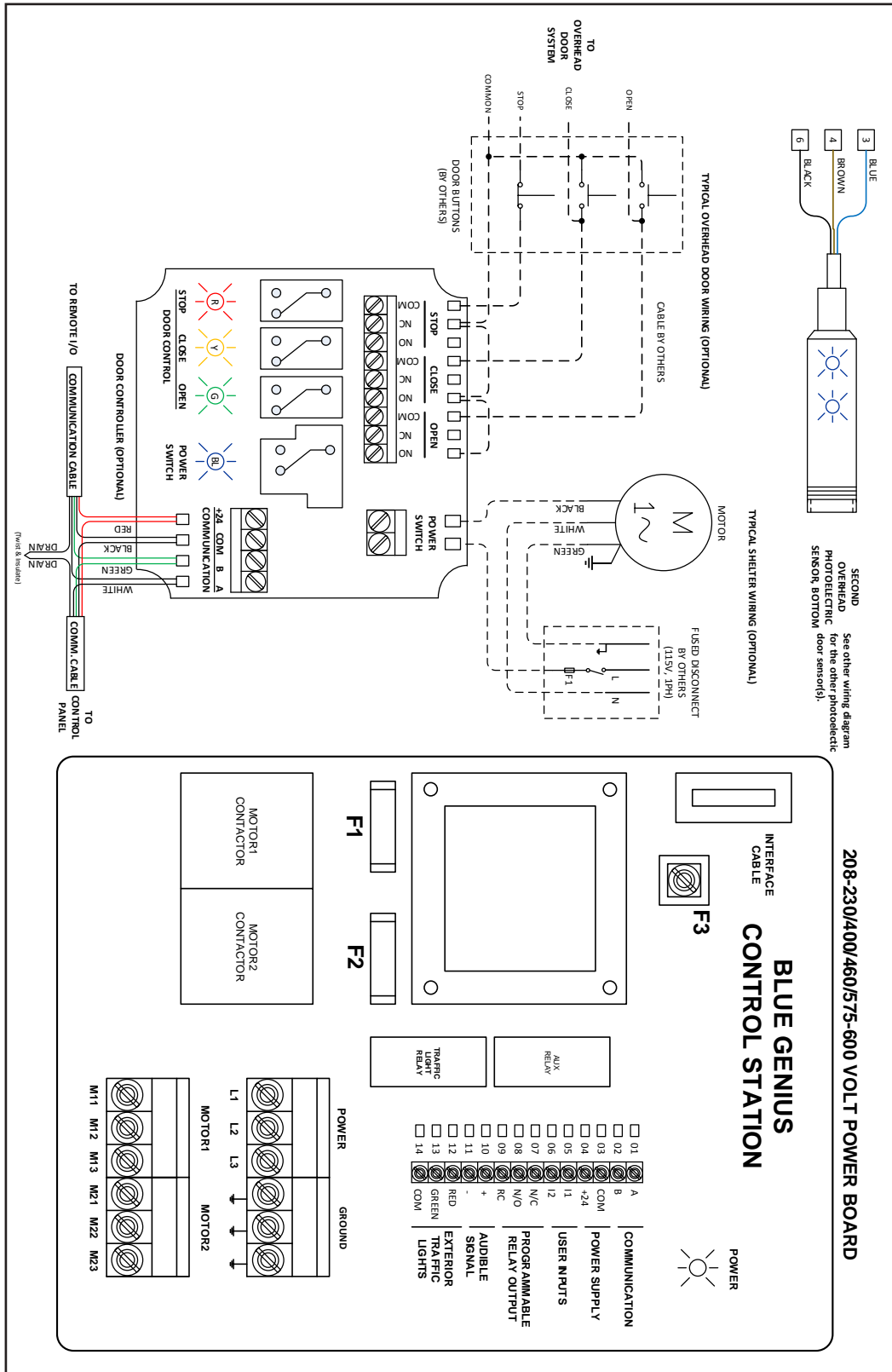

NOTE: Refer to both wiring diagrams for the two door sensor wiring arrangements.

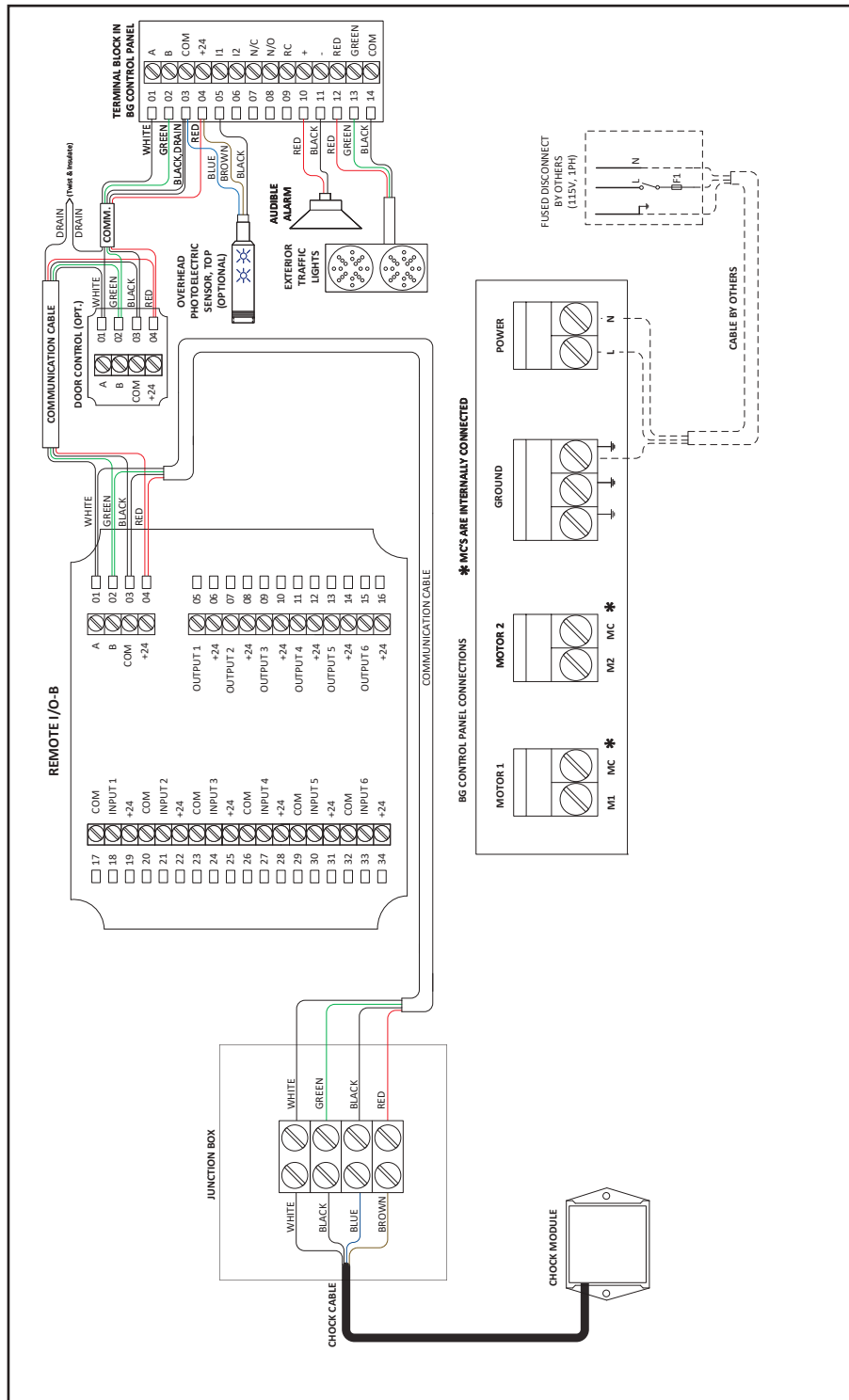

NOTE: Refer to both wiring diagrams for the two door sensor wiring arrangements.

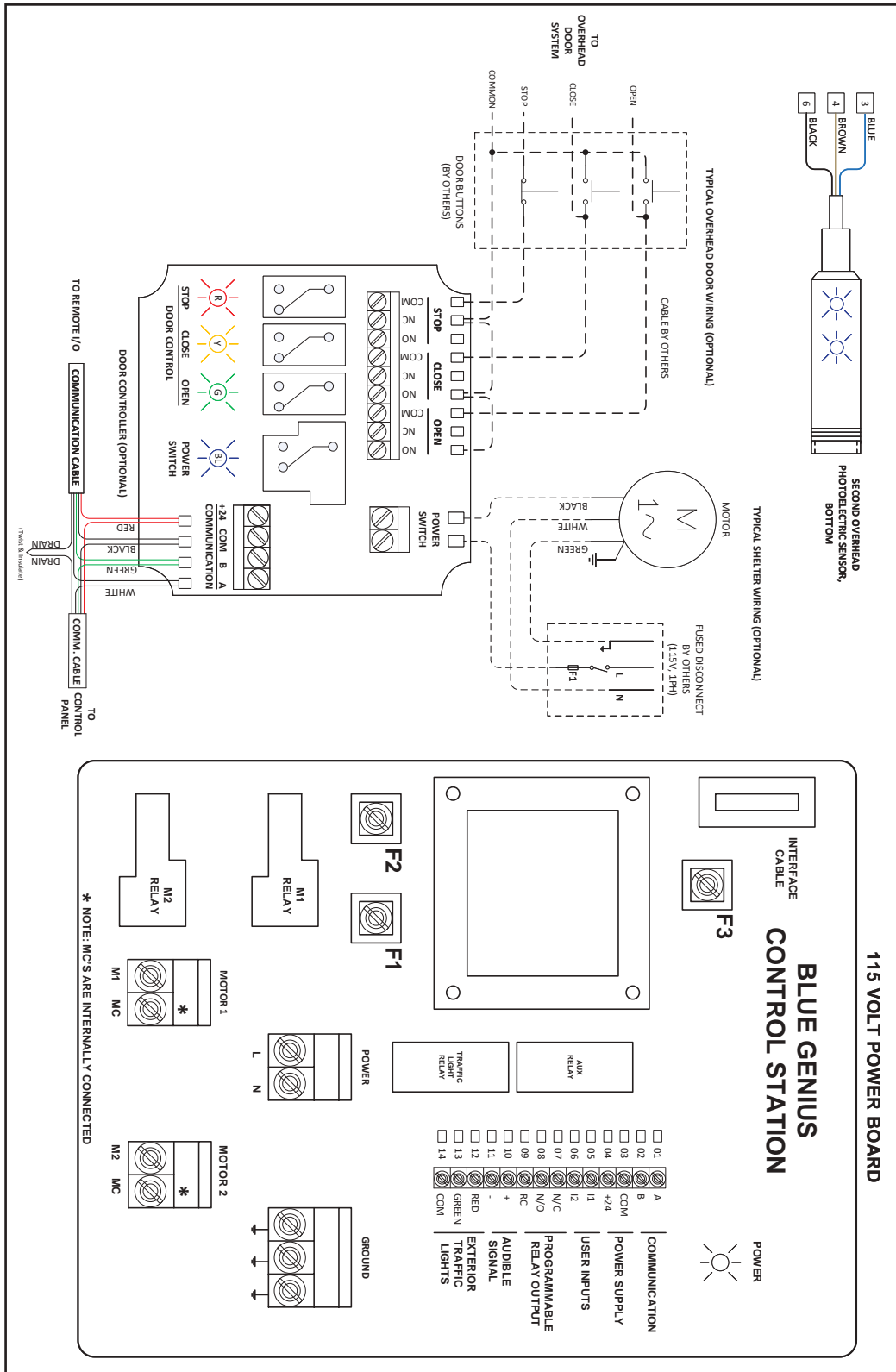

BLUE GIANT[®]
BLUE GIANT EQUIPMENT CORPORATION

Corporate 410 Admiral Blvd
Mississauga, ON, Canada L5T 2N6
t 905.457.3900 f 905.457.2313

USA 6350 Burnt Poplar Road
Greensboro, NC 27409
www.bluegiant.com