

OWNER'S MANUAL

AIRBAG DOCK LEVELER WITH CONTROLS



ACTUAL PRODUCT MAY NOT APPEAR EXACTLY AS SHOWN



WARNING

Do not operate or service this product unless you have read and fully understand the entire contents of this manual. Failure to do so may result in property damage, bodily injury or death.

BLUE GIANT[®]

TABLE OF CONTENTS

1.0	ABOUT THE AIRBAG DOCK LEVELER WITH CONTROLS	4
1.1	OWNER'S PURCHASE RECORD	4
2.0	INTRODUCTION	5
2.1	WARRANTY INFORMATION	5
2.2	EXCLUSION OF LIABILITY	5
2.3	MANUFACTURER'S NOTE	5
2.4	OWNER'S RESPONSIBILITY	6
3.0	OPERATOR'S MANUAL SAFETY MESSAGE COLOR IDENTIFICATION	7
3.1	OPERATIONAL SAFETY WARNINGS	7
4.0	LOCKOUT / TAGOUT PROCEDURE AND RULES	8
5.0	CONTROL STATION OPERATION	9
5.1	BUTTON FUNCTION	9
6.0	MAINTENANCE STAND SET-UP	10
6.1	ENGAGING THE MAINTENANCE STAND	10
6.2	DISENGAGING THE MAINTENANCE STAND	10
7.0	MAINTENANCE	11
7.1	PLANNED MAINTENANCE	11
7.2	OPERATOR DAILY INSPECTION	11
7.3	ROUTINE SERVICING AND MAINTENANCE	11
7.4	PLANNED MAINTENANCE INTERVALS	11
7.6	MAINTENANCE SEQUENCE	11
8.0	OPERATING INSTRUCTIONS	12
8.1	FUNCTIONAL DESCRIPTION	12
8.2	DEPLOYING THE DOCK LEVELER	13
8.3	STORING THE DOCK LEVELER	13
8.4	BELOW LEVEL / END LOADING	14
9.0	DAILY MAINTENANCE PROCEDURES CHECKLIST - AIRBAG DOCK LEVELER	15
10.0	RECOMMENDED SPARE PARTS	16
10.1	OPTIONAL SUPPORT COMPONENTS	17
11.0	DECAL IDENTIFICATION AND LOCATION	18

TABLE OF CONTENTS CONT'D.

12.0 EQUIPMENT COMPONENT ILLUSTRATIONS	19
12.1 COMPONENTS AS SHIPPED CHECK LIST	19
12.2 MECHANICAL ASSEMBLY	20
12.3 AIRBAG AND PLATFORM ASSEMBLY	22
12.4 DECK SIZE AND CAPACITIES	23
12.5 LIP SIZE AND CAPACITIES	23
12.6 FRAME SIZE	24
12.7 PIT DIMENSIONS	24
12.8 CONTROLS	25
13.0 DOCK LEVELER TROUBLESHOOTING	26
14.0 WIRING DIAGRAMS	27
14.1 SP1 WIRING DIAGRAM—110–130V SINGLE PHASE	27
14.2 SP1 WIRING DIAGRAM—208–240V SINGLE PHASE	28
15.0 ALTERNATIVE CONTROL STATION OPTIONS	29
15.1 SP2 CONTROLS	29
15.2 BLUE GENIUS™ CONTROLS	30
15.3 WIRING DIAGRAMS	30
15.4 SP2 WIRING DIAGRAM—115V SINGLE PHASE	31
15.5 SP2 WIRING DIAGRAM—230V SINGLE PHASE	32
15.6 BLUE GENIUS™ GOLD WIRING DIAGRAM—115V SINGLE PHASE	33
15.7 BLUE GENIUS™ GOLD WIRING DIAGRAM—230V SINGLE PHASE	34
15.8 OPTIONAL EXTERIOR TRAFFIC LIGHT / MIRROR IMAGE SIGN	35
15.9 OPTIONAL DOCK INTERLOCK SENSOR	35

1.0 ABOUT THE AIRBAG DOCK LEVELER WITH CONTROLS

The Airbag Dock Leveler combines Blue Giant’s advanced, environmentally friendly air lifting system with the same durable structural design that has made Blue Giant a global leader in the design, manufacture, and distribution of loading dock systems.

Supported by a minimum of six heavy-duty U-beams, the airbag dock leveler has a high-volume, low-pressure (HVLP) air lifting system that is both easy and ergonomic to operate. When activated via the single push-button control station, the air bag inflates, raising the deck and deploying the lip. After the button is released, the bag deflates, allowing the deck to lower smoothly onto the trailer bed.

The airbag dock leveler operates safely and efficiently under the toughest conditions: temperature extremes, heavy usage, and exposure to caustic substances. The deck compensates laterally when under load to allow a smooth cross-docking transition, minimizing the risk of worker injury and cargo or equipment damage. Mechanical fall-safe legs limit platform free-fall, providing an added degree of protection at the loading dock.

1.1 OWNER’S PURCHASE RECORD

OWNER’S PURCHASE RECORD	
Please record information for future inquiries and to validate warranty. (See Section 2.1 "Warranty Information" for warranty validation)	
Dealer:	Date in Service:
	Number of Units:
Serial Number:	Door #:
Serial Number:	Door #:
Serial Number:	Door #:
Serial Number:	Door #:
Serial Number:	Door #:
Serial Number:	Door #:
Serial Number:	Door #:
Serial Number:	Door #:
Serial Number:	Door #:
Serial Number:	Door #:
Serial Number:	Door #:

The manufacturer offers a full line of dock levelers, dock safety equipment, accessories, ergonomic and scissor lift equipment, seals and shelters, and industrial trucks. Concurrent with a continuing product improvement program, specifications are subject to change without notice (See Section 2.2 "Exclusion of Liability" of this manual). Please contact the manufacturer for latest information. Some features illustrated may be optional in certain market areas.

NOTICE
See Section 11.0 "Decal Identification and Location" item #5 for serial number location.

2.0 INTRODUCTION

The following is a quick reference to important procedures that must be followed while using the Loading Dock Equipment. It is not intended to cover, or suggest that it does cover, all procedures necessary to ensure safe operation. All operators should be aware of and abide by all workplace safety regulations applicable to the operation of the Loading Dock. These laws and regulations include but are not limited to:

- The Occupational Safety and Health Act
- Canada Occupational Health and Safety Regulations
- Occupational Safety and Health Acts for Individual States (USA)

For additional information on these regulations as well as industry standards that may apply to this product, please contact:

American National Standards Institute (ANSI)
1430 Broadway
New York, NY 10018
Telephone: 212.642.4900
www.ansi.org



Also a member of:



Loading Dock Equipment Manufacturers
A Product Section of Material Handling Industry of America
A Division of Material Handling Industry
8720 Red Oak Blvd, Suite 201
Charlotte, NC, 28217-3992
Telephone: 704.676.1190
www.mhi.org/lodem

2.1 WARRANTY INFORMATION

Thank you for purchasing Blue Giant products. We appreciate your business, and are confident that our product will serve you for many years to come. In the event that you experience a problem with our product, our Warranty Center is here to support the Blue Giant Product(s) that you have purchased.

To validate warranty on recently purchased equipment, please complete and submit your information with our on-line Warranty Registration at www.BlueGiant.com.

For more information about Blue Giant Warranty Support, please contact your local Blue Giant Equipment dealer, representative or authorized partner near you. You may also visit www.BlueGiant.com or phone 1.905.457.3900.

DEALER INFORMATION

Name:

Contact:

Telephone:

* **NOTE** that failure to validate warranty at the time of receipt can seriously affect the outcome of any claim.

2.2 EXCLUSION OF LIABILITY

The manufacturer assumes no liability for damage or injury to persons or property which occur as a result of defects or faults in or incorrect use of the Loading Dock Equipment. The manufacturer also assumes no liability for lost profits, operating downtimes, or similar indirect losses incurred by the purchaser. Injury to third parties, irrespective of its nature, is not subject to compensation.

The manufacturer reserves the right to make changes at any time to the modules, components, and accessories, concurrent with its continuing product improvements and development program. Specifications, operating instructions, and illustrations included in this manual are subject to change without notice. Please contact manufacturer for the latest information.

2.3 MANUFACTURER'S NOTE

The dock equipment has been carefully inspected and tested at the manufacturer's plant prior to shipment, but should be checked upon receipt for transport damage. Any observed transport damage is to be listed on the signed copy of the freight document. Notify the freight forwarder of any damage WITHIN 48 HOURS.

2.4 OWNER'S RESPONSIBILITY

1. The owner should recognize the inherent danger of the interface between the dock and the freight carrier. The owner should, therefore, train and instruct operators in the safe use of the dock equipment and accessories in accordance with the manufacturer's recommendations.
2. The owner should thoroughly familiarize themselves with the following procedures and specifications, and request immediate replacement of all manufacturer-supplied documents that are missing, damaged, or otherwise illegible. Below is a list of Best Practices for dock equipment usage and maintenance.
 - Commissioning instructions
 - Operating instructions
 - Daily maintenance procedures checklist
 - Inspections procedures
 - Recommended spare parts lists
3. All Blue Giant dock equipment should undergo regularly scheduled planned maintenance. Maintenance requirements will vary according to usage frequency and application, so the owner shall consult with their authorized Blue Giant distributor for schedule recommendation. Written records of the performance of these procedures should be kept as per warranty requirements.
4. Dock equipment that is structurally damaged, experiencing performance irregularities, or has been potentially compromised shall be removed from service until a trained and authorized manufacturer's representative can conduct an inspection and perform any necessary repairs.
5. As with any piece of machinery, dock equipment requires routine maintenance, lubrication, and adjustments. Recommended procedures are itemized in the Planned Maintenance Program (PMP) checklist included in installation and technical manuals. It is recommended that for anything other than the basic maintenance procedures outlined in this manual, you contact your local Blue Giant representative.
6. The owner shall ensure that all name plates and safety labels are in place and legible, and that the appropriate manuals are provided to authorized users. Replacement name plates, safety labels, and manuals are available through the Blue Giant Aftermarket Department. See "Decal Identification and Location" section in this manual for more information.
7. The owner or a trained and authorized representative shall verify that all freight carrier brakes have been applied and a vehicle restraint and/or wheel chocks properly engaged before cross-docking procedures begin. For safety reasons trailers must be held securely in place to avoid accidental separation from the loading dock.
8. Unless specifically agreed to in writing by Blue Giant Equipment Corporation at the time of order (and prior to manufacture), all Blue Giant Dock equipment is sold as a complete offering and must not be altered or added to in any manner (which includes configuration and function) without written permission from an authorized manufacturer's representative. These changes shall also satisfy all safety recommendations of the original equipment manufacturer for the particular application of the dock equipment.
9. If, at the request of the owner, Blue Giant does not supply all or some of the dock equipment power unit and/or control panel components, the owner shall assume responsibility for any and all operational and safety issues associated with the resulting configuration.

3.0 OPERATOR'S MANUAL SAFETY MESSAGE COLOR IDENTIFICATION

This manual includes color-coded safety messages that clarify instructions and specify areas where potential hazard exists. To prevent the possibility of equipment damage and serious injury or death, please observe strictly the instructions and warnings contained in the messages. If warning decals become damaged or missing, replace them immediately. Avoid accidents by recognizing dangerous procedures or situations before they occur.

 DANGER
Serious injury or death will likely occur if the instructions are not followed.

NOTICE
Procedures marked important must be followed in order to prevent damage to machinery.

 WARNING
Serious injury or death may occur if the instructions are not followed.

 CAUTION
Instructions marked caution concern safe operating procedure. Failure to comply may result in personal injury.

3.1 OPERATIONAL SAFETY WARNINGS

 DANGER
<ol style="list-style-type: none"> 1. Do not enter the pit area below the dock leveler. 2. BEFORE BEGINNING ANY SERVICE PROCEDURES: <ul style="list-style-type: none"> – Disconnect the power and follow all lockout / tagout procedures. 3. Never operate a broken or damaged dock leveler. Have repairs done immediately by a qualified service technician. 4. Always secure and center loads on the forklifts. Loose or unbalanced loads are dangerous.

NOTICE
<ol style="list-style-type: none"> 1. Do not ground welding equipment to any electrical components. 2. Do not attach welder as ground to leveler platform when welding on base frame assembly. Attach welder ground to base frame assembly only. 3. Do not allow the drill to go too deeply when drilling holes in the control box. Damage to the control systems may occur. 4. Never use air to blow debris from control box. Use a vacuum to remove debris from control box. 5. Do not connect green ground lead into control box until all welding has been completed. 6. Always keep the work area clean and free of litter. 7. Always clean all side openings of dirt and debris. 8. Always clean all dirt and debris from the lip hinge. 9. Always clean up dry and liquid spills immediately after they occur. 10. Always maintain proper lighting in the work area. 11. If a procedure is not clearly defined in this manual, contact your authorized Service Representative.

 WARNING
<ol style="list-style-type: none"> 1. The upper hinge point is a hazardous pinch point. Do not use fingers or hands to remove foreign materials. 2. Post safety warnings and barricade working area at dock level and at ground level to prevent unauthorized use of the leveler during maintenance/service. 3. Never leave the dock leveler unattended in the raised position. 4. Always make sure that the lip is seated inside the night lock after putting the dock in the parked position. 5. Never leave loads sitting on the dock leveler. 6. Do not attempt to raise the dock leveler if someone is standing on it. 7. Do not use the dock leveler if the lip's full width is not fully supported by the vehicle load bed. 8. Do not operate the dock leveler beyond its rated capacity. 9. Do not drive or walk onto the truck until it is parked against the dock bumpers and the wheels are chocked, or the vehicle restraint has been fully engaged. 10. Never attempt to lift or hold the lip out by hand. Serious personal injury could occur. 11. Never remove the wheel chocks until loading/ unloading is finished and the truck driver has been given permission to depart.

 CAUTION
<ol style="list-style-type: none"> 1. Only trained personnel should operate or service this equipment. 2. Do not operate the dock equipment until the transport vehicle is parked against the dock bumpers. 3. Always park the dock equipment after use. 4. Conduct routine inspections and maintenance. Failure to do so could cause equipment damage and or personal injury. 5. Always call your authorized service representative or manufacturer immediately if a malfunction occurs.

4.0 LOCKOUT / TAGOUT PROCEDURE AND RULES

In accordance with the rules and regulations of the Occupational Safety and Health Administration (OSHA), all affected employees must be notified that the machine or equipment will be shut down and locked out to perform repair or maintenance work. The work area must be checked to ensure that all personnel have been removed or safely repositioned. The machine or equipment power supply shall be locked in the OFF position or disconnected from the energy source. Blue Giant strongly recommends that only OSHA-approved lockout devices and procedures be utilized.

The energy isolating device must bear a prominent warning tag indicating that work is being done on the equipment and the name of the authorized employee responsible for the lockout. It is mandatory that tagout notices not be susceptible to deterioration or illegibility due to weather conditions or exposure to chemicals and moisture.

 **WARNING**

Always lockout and tagout any power source before performing any work on any electrical devices or electrical controls according to OSHA regulations and approved local electrical codes.

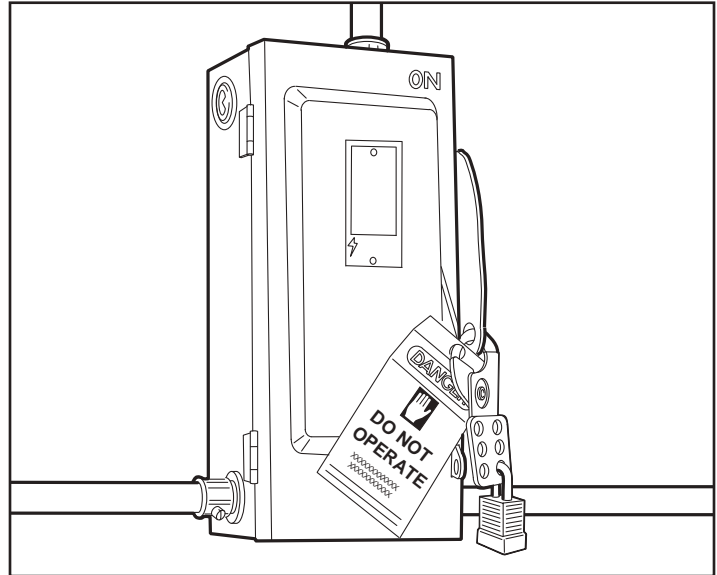

Approved way to lockout / tagout.

5.0 CONTROL STATION OPERATION

INDEPENDENT TYPE CONTROL STATION

Controls one individual dock leveler only, equipped with a constant-pressure 'UP' button.

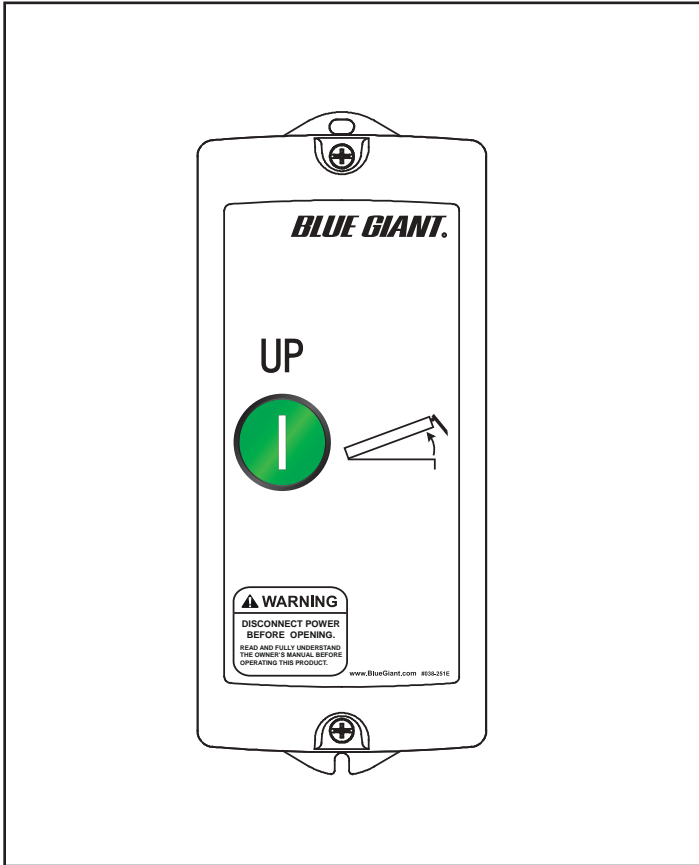

5.1 BUTTON FUNCTION

'UP' button activates the dock leveler when pressed and held.

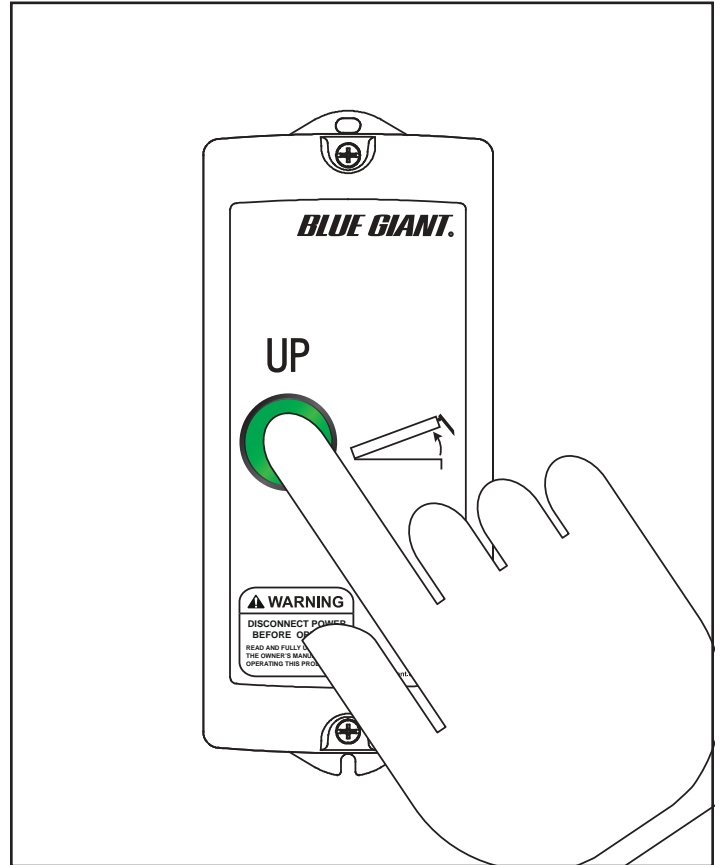

Note: Contactors come standard with control box.

CAUTION

For safety reasons, the operator's view of the moving dock leveler must not be obstructed at any time. Potential obstructions include but are not limited to the dock wall, curtains, and stacked cargo. Ensure that the operator's field of vision is clear throughout the dock leveler operating cycle.

6.0 MAINTENANCE STAND SET-UP



DANGER

Never work in the path of the dock leveler platform without engaging the maintenance stand. If the device cannot be engaged successfully, contact your authorized service representative or the manufacturer.



WARNING

Post safety warnings and barricade work area at dock level and at ground level to prevent unauthorized use of the dock leveler during maintenance/service.

6.1 ENGAGING THE MAINTENANCE STAND



WARNING

Do not attempt to apply the maintenance stand until the deck and lip are both fully deployed.



CAUTION

Use of a secondary safety stand (Blue Giant Part # 796-710) in conjunction with the maintenance stand is strongly recommended.

This dock comes with a one-piece maintenance stand that must be used during under-dock inspections or repairs / maintenance. The V-shaped groove ensures safe headboard and lip support.

To apply the maintenance stand, one person raises the deck while another puts the stand in place and inserts the locking pin at its base to secure it.

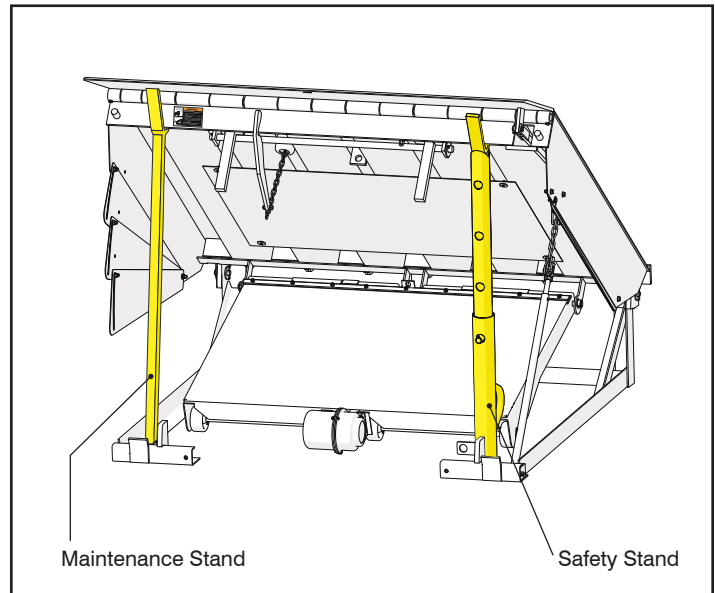

Engaged Maintenance Stand (part # 26-011895) and Safety Stand (part # 796-710).

6.2 DISENGAGING THE MAINTENANCE STAND

After verifying that it is safe to disengage the maintenance stand, remove the locking pin from the mounting bracket and have someone press and hold the control station “UP” button.

Once the deck and lip are clear of the maintenance stand, carefully push the device back into the pit.

Do not stand in the pathway of the dock leveler during the disengagement process in case the dock falls unexpectedly.

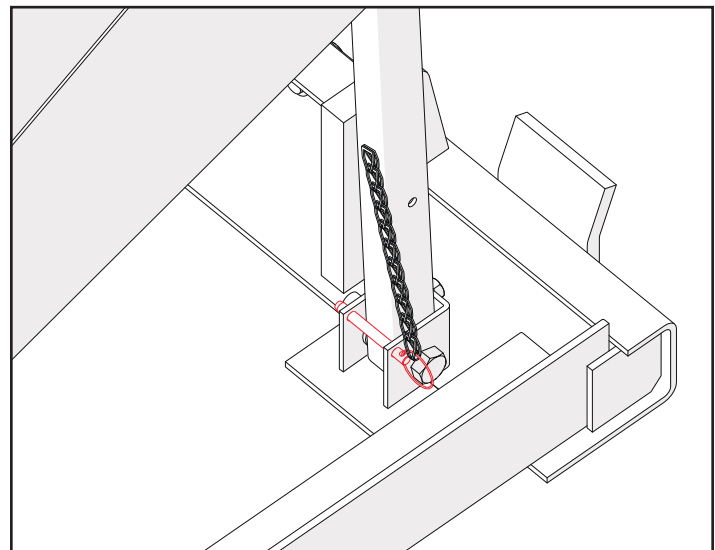

Locking pin in secure position, if desired a padlock may also be used instead of the locking pin.

7.0 MAINTENANCE



WARNING

Do not operate and/or service this dock leveler until you have read and understood all of the safety information and instructions contained herein and on the dock leveler.

Do not work under or around dock leveler without first placing adequate barriers to positively prevent vehicle traffic from entering the work area.

Follow proper lock-out/tag-out procedures.

Keep hands and feet clear of dock leveler pinch points and wear appropriate safety attire - glasses, gloves and work boots.

The maintenance strut must be in place before commencing maintenance procedures.

7.1 PLANNED MAINTENANCE PROGRAM (PMP)

In addition to the daily operator inspection, the manufacturer recommends (and local government regulations may require) that a planned maintenance program (PMP) and safety inspection program be performed by a trained and authorized service technician on a regular basis to maintain the equipment in safe operating condition. The PMP will provide an opportunity to make a thorough inspection of the safety and operating condition of the dock leveler. Necessary adjustments and repairs can be done during the PMP, which will increase the life of components and reduce unscheduled downtime.

Recommended procedures for a periodic planned maintenance program that covers inspections, operational checks, cleaning, lubrication, and minor adjustments are outlined in this manual. An authorized dealer or distributor is prepared to assist with a planned maintenance program by offering trained service personnel with expertise in dock leveler maintenance requirements.

7.2 OPERATOR DAILY INSPECTION

The dock leveler should always be examined by the operator **PRIOR TO ANY USE** to verify that it is safe to operate.

The manufacturer recommends making multiple photocopies of the PMP Checklist (See Section 9.0 "*Checklist - Airbag Dock Leveler - Operator and Planned Maintenance Program.*") The operator should fill out this form to keep a daily record of operation and maintenance issues.

7.3 ROUTINE SERVICING AND MAINTENANCE

Regular maintenance and care of the dock leveler is very important for cost and operation efficiency and more importantly; operator safety. A faulty dock leveler is a potential source of danger to the operator, and to other personnel working near it. As with all quality equipment, keep the dock leveler in good operating condition by following the recommended schedule of maintenance.

Failure to properly maintain or operate the dock leveler within its rated capacity can void the manufacturer warranty.

7.4 PLANNED MAINTENANCE PROGRAM INTERVALS

Arrange for a qualified dock leveler repair technician to perform regularly scheduled planned maintenance on your dock leveler every three months for single shift operations or monthly for multi-shift operations. Call your authorized manufacturer/ dealer for further details.

7.6 MAINTENANCE SEQUENCE

1. Cleaning, including pit area.
2. Visual inspection of all components.
3. Lubrication, as required (by a trained service technician only).
4. Test operate all functions.
5. Adjustments, if required (by a trained service technician only).
6. Check for missing or damaged dock bumpers.
7. Record inspection details and findings for owner's files.

8.0 OPERATING INSTRUCTIONS

WARNING

Do not operate this leveler unless you have been trained and authorized to do so, and have read and understood all of the safety information and instructions contained herein.

Do not operate the dock leveler beyond its rated capacity.

Do not operate this leveler until you have checked its condition. Report the need for repairs to your supervisor immediately and do not operate the unit until repairs are made. Neglect may cause a minor repair to become a major service problem and cause the leveler to become unsafe.

Never try to lift or move any part of the dock leveler manually.

Do not drive on the leveler unless the lip is securely on the truck bed and has a minimum of 4" (102mm) overlap on its surface.

Do not exceed 4 mph when driving over the dock leveler.

Do not drive over edges of the leveler and / or dock bumper blocks (bumpers blocks are not structural).

Confirm brakes have been set and air has been removed from the air-ride suspension (if applicable).

OPERATING INSTRUCTIONS
Only for Single Push Button Dock Levelers

A

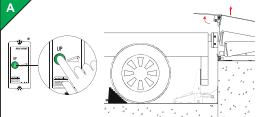

B

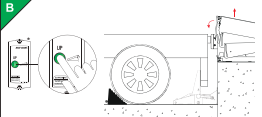

C



DEPLOYING THE DOCK LEVELER

1. Raise the leveler by pressing the "UP" button. Continue holding the "UP" button until the leveler is in its fully raised position, at which time the lip will deploy.
2. Release the "UP" button once the lip has fully deployed. The leveler will then descend with the deployed lip on the vehicle load bed. When the leveler has fully deployed on the load bed, loading and unloading may commence.

STORING THE DOCK LEVELER

1. To store the leveler, press the "UP" button. The leveler will raise and the lip will retract.
2. When the lip has fully retracted, release the button. The leveler will lower into the stored position with the lip in the home position.

BELOW LEVEL / END LOADING

A. HYDRAULIC LEVELER ONLY: Raise the dock leveler by pressing the "UP" button. Continue holding the "UP" button until the dock is in its fully raised position. Release the "UP" button once the lip has partially deployed (2'-3") and let the leveler lower to the below level position, with the lip hanging between the dock face and the truck bed.

B. AIRBAG LEVELER ONLY: Raise the dock leveler by pressing the "UP" button. Release the "UP" button when the lip clears the right lock by 6"-10". While the dock is lowering, pull the fall-safe disengaging chain on the deck to partially extend the lip and to lower to the below level position.

⚠ DANGER

1. Only trained and authorized personnel may operate this dock leveler.
2. Read, understand, and follow the instructions on this document.
3. Prior to using the dock leveler:
 - Ensure that the dock leveler is free and clear of all debris, snow and ice.
 - Ensure that all personnel near the dock leveler are aware that it is being operated.
 - Operate the dock leveler through one complete cycle to confirm that it is functioning properly. If the dock leveler is equipped with a communications package, confirm that the lights are working as required.
 - Inspect unit for signs of structural damage or mechanical malfunction. If damage is observed or the restraint fails to operate properly, remove it from service and notify maintenance personnel immediately.
4. When using the dock leveler:
 - Confirm that the transport vehicle has been properly restrained.
 - Keep hands and feet clear of pinch points.
 - If the dock leveler is equipped with a light communication package, load and unload on green only.
 - Do not exceed the rated capacity as indicated on the serial plate.
 - Do not leave equipment or material unattended on the dock leveler.
 - Keep a safe distance from both edges.
 - If dock leveler fails to operate as outlined in the accompanying manual's operating instructions, refer to the Troubleshooting section.
5. If service or maintenance is required:
 - Only authorized service personnel shall maintain or service the unit.

APPLIES TO ALL DOCK LEVELERS

BLUE GIANT www.BlueGiant.com 038-757E

Airbag Dock Leveler operation placard—part # 038-757E.

8.1 FUNCTIONAL DESCRIPTION

The Airbag Dock Leveler serves as a bridge between a loading dock floor and a truck bed. The leveler’s upper deck plate, complete with a hinged, vertically hanging lip, is in a shallow pit at the edge of the dock, flush with the dock’s edge and the floor surface.

After the door has been opened, the rear of a transport vehicle is parked and restrained in place against the outer wall of the loading dock, in working alignment with the dock leveler. To activate the dock leveler, press the 'UP' button on the control station. The air bag will inflate, raising the deck.

Once the lip extends, release the button. The bag will deflate, allowing the deck to lower onto the truck bed.

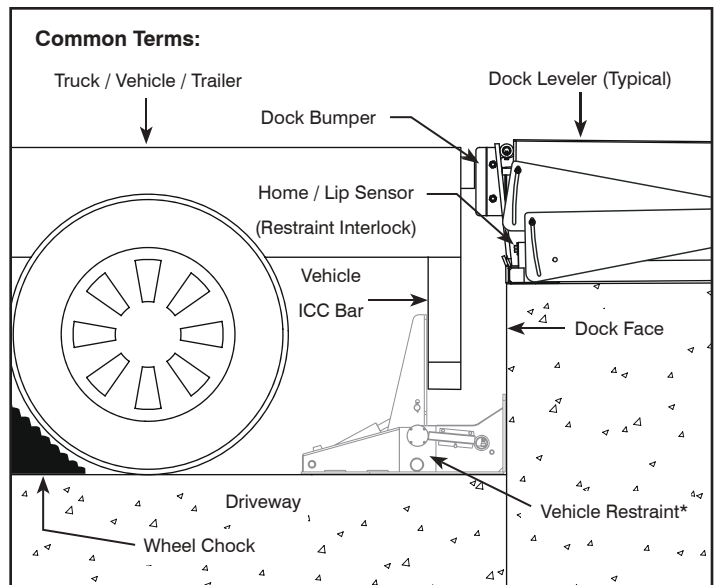

* For Reference

STANDARD OPERATION PROCEDURES

8.2 DEPLOYING THE DOCK LEVELER

1. Raise the dock leveler by pushing the 'UP' button. If the button is still being pressed while the dock is in its fully raised position, the lip will then deploy.
2. The dock leveler will then descend with the deployed lip on the vehicle load bed. When the dock has fully deployed on the load bed, loading and unloading may commence.
3. After ensuring that there is a minimum overlap of 4" (102mm) between the dock leveler lip and the truck bed, begin loading or unloading.

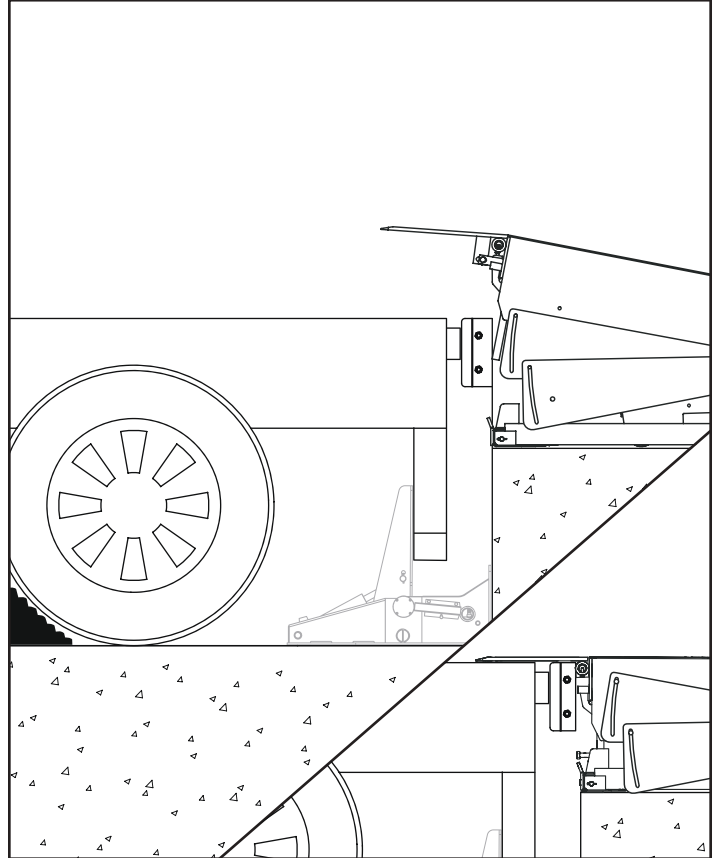
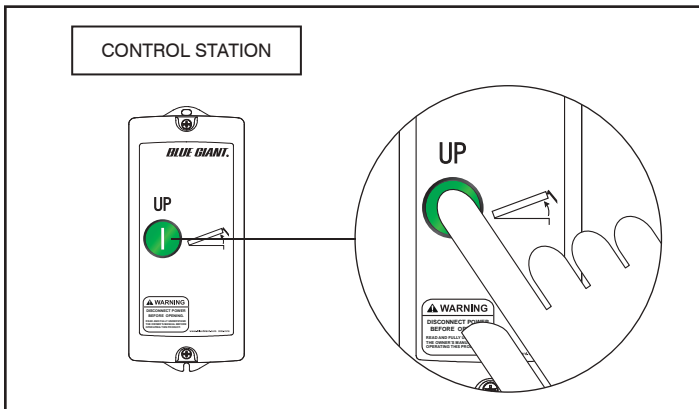

8.3 STORING THE DOCK LEVELER

1. To store the dock leveler, press the 'UP' button. The dock will raise and the lip will retract.
2. When the lip has fully retracted, release the button. The dock will resume the stored position with the lip in the night lock.
3. Disengage the vehicle restraint (if applicable) and / or remove the wheel chocks, allowing the truck to depart.

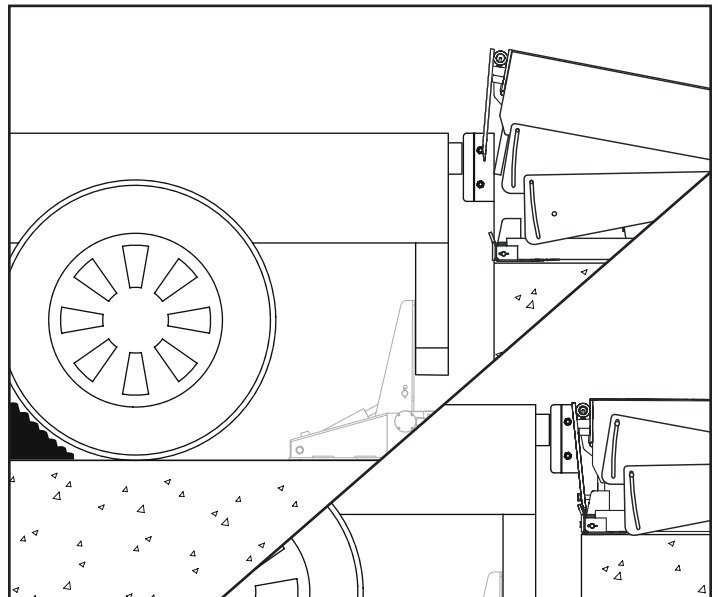

8.4 BELOW LEVEL / END LOADING

1. After the truck has been chocked and / or restrained in place, hold the control station's 'UP' button until the lip clears the night lock by approximately 6-10".
2. Then release. While the deck is lowering, pull the fall-safe disengaging chain on the deck to partially extend the lip and to lower to the below level position, with the lip hanging between the dock face and the truck bed.
3. When below level / end loading is complete, resume normal leveler operation by pressing and holding the 'UP' button until the deck is raised and the lip is fully extended.

Release the button and allow the deck to lower onto the truck bed. If end loading was the last operation, press and hold the 'UP' button until the lip clears the night lock and then release. The deck will fall back into the stored position.

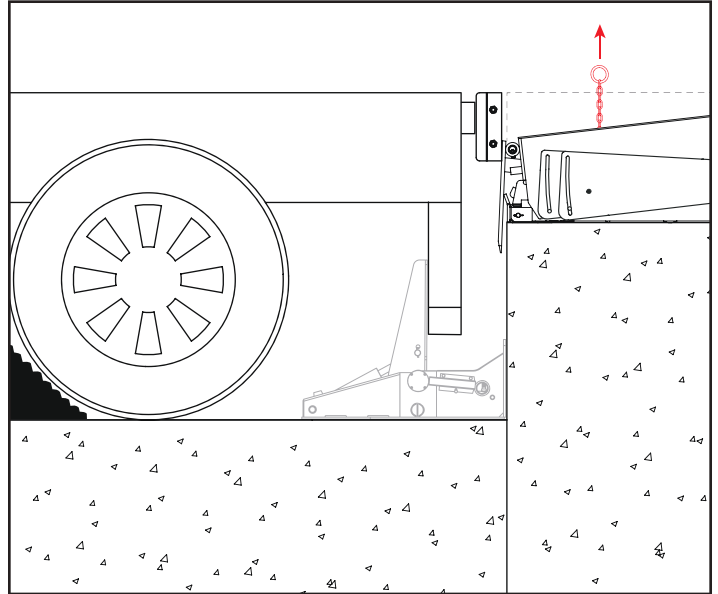

9.0 DAILY MAINTENANCE PROCEDURES CHECKLIST - AIRBAG DOCK LEVELER

INSPECTED BY: _____ **DATE:** _____

SERIAL #: _____ **DOOR #:** _____

Forward this checklist to the person responsible for dock equipment maintenance. See Section 1.1 "Owner's Purchase Record" for Date in Service.

INSTRUCTIONS FOR USE: Indicate "OK for USE" with a check mark ✓ in the appropriate box of each inspection point.

EVERY DAY (MAY BE PERFORMED BY OWNER OR ATTENDANT):

- Remove any debris that may have accumulated around the dock equipment
- Verify complication-free operation of the dock equipment and the interior and exterior lights system (if installed)
- Verify that outside signage is present and legible (if equipped)
- Verify complication-free operation of the SP1 / SP2 / Blue Genius™ Control Panel (whichever is equipped)
- Verify that dock bumpers/risers are in working condition
- Check backframe for irregularities (e.g. concrete cracks)
- Verify that the maintenance stand is functional
- Verify that instructional caution and danger labels are present and legible on the product. Replace if necessary
- Verify that operational placards are present and legible

PHOTOCOPY THIS CHECKLIST AND FILL OUT REGULARLY FOR YOUR RECORDS.

Explain faults briefly in the space provided below:

DANGER

When repairing or conducting maintenance procedures on electrical components, perform lockout / tagout steps according to OSHA regulations and approved electrical codes.

DANGER

Prior to installation, place adequate barriers to prevent unauthorized personnel and vehicle traffic from entering the work area.

WARNING

All repairs and maintenance work are to be conducted by trained and authorized personnel ONLY.

10.0 RECOMMENDED SPARE PARTS

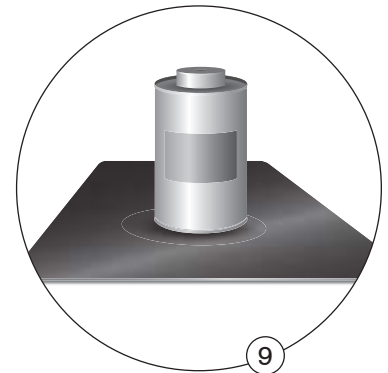
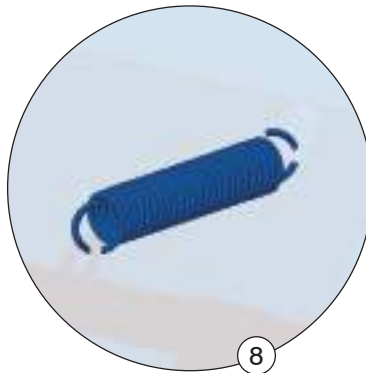
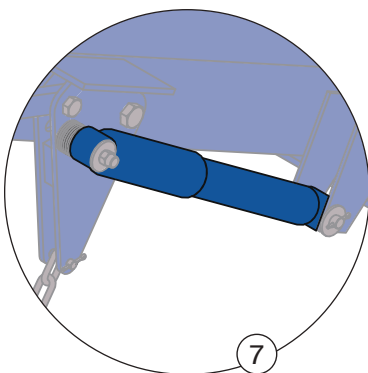
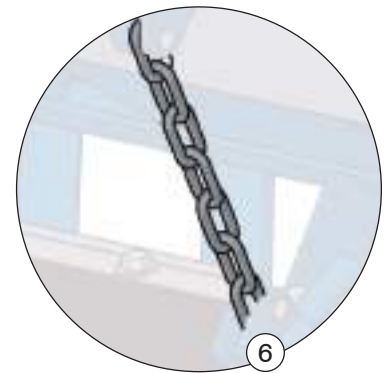
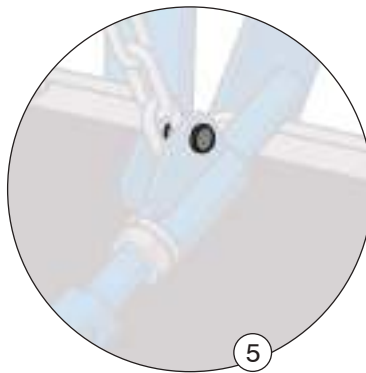
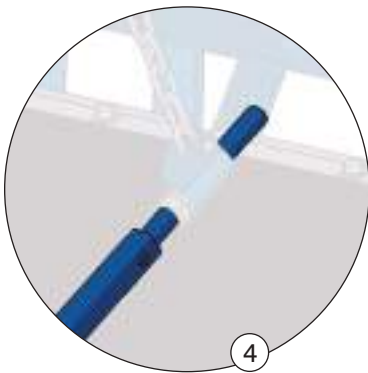
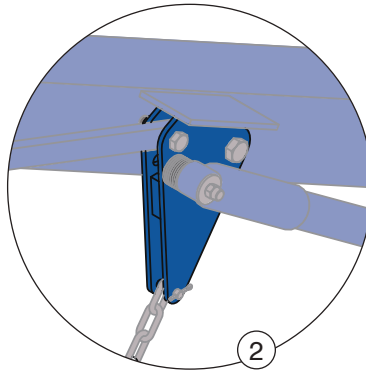
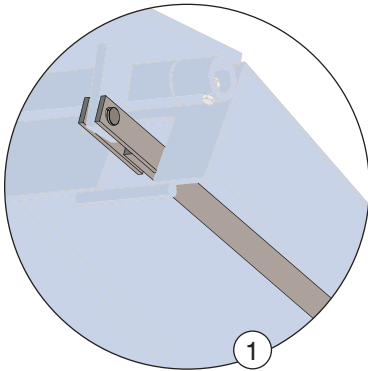

10.0 RECOMMENDED SPARE PARTS

REPLACEMENT PARTS AIRBAG DOCK LEVELER			
ITEM	PART NO.	DESCRIPTION	QTY REQ'D
1	26-011298	Push Rod, Lip Deploy	1
2	26-011300	Link Plate, Lip Deploy	1
3	26-011555	Lip Deploy	1
4	26-011558	Lower Link Weldment	1
5	013-542	Pin 3/8" Dia. x 1-3/8", Lip Deploy	2

REPLACEMENT PARTS AIRBAG DOCK LEVELER			
ITEM	PART NO.	DESCRIPTION	QTY REQ'D
6	26-011305	Chain Assembly (6' L)	1
	26-011304	Chain Assembly (8 & 10') L	1
7	200-02397	Shock Absorber	1
8	071-012	Tension Spring, Fall-Safe	1
9	080-900-1	Patch Kit (includes 1 pc of 60" x 36" vinyl and glue)	1

10.0 RECOMMENDED SPARE PARTS CONT'D.



10.1 OPTIONAL SUPPORT COMPONENTS

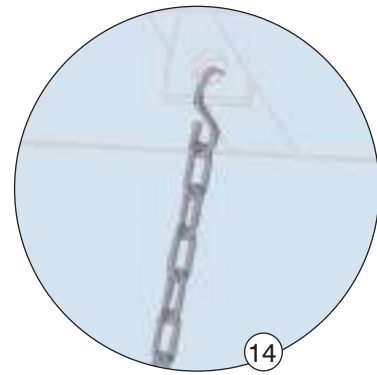

10.0 RECOMMENDED SPARE PARTS

REPLACEMENT PARTS FOR AIRBAG DOCK LEVELER			
ITEM	PART NO.	DESCRIPTION	QTY REQ'D
10	R2-40026-1200	Power Cable - 10' L (* Optional)	1
Blower Motor (1PH / 60Hz) Only			
11	26-012925	115V	See Section 12.3 for breakdown of parts included
	26-012925-1	230V	
12	26-013413	Airbag	6' L
	26-012962		8' L
	26-013389		10' L
13	020-015	Polypropylene Wheel	4

10.1 OPTIONAL SUPPORT COMPONENTS

OPTIONAL SUPPORT COMPONENTS FOR AIRBAG DOCK LEVELER			
ITEM	PART NO.	DESCRIPTION	QTY REQ'D
14	26-011563	Maintenance Holder for Tray and Bag	1

11.0 DECAL IDENTIFICATION AND LOCATION

1 

4 

2 

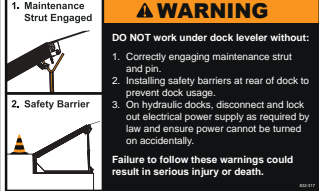
3 

6 

7 

8 

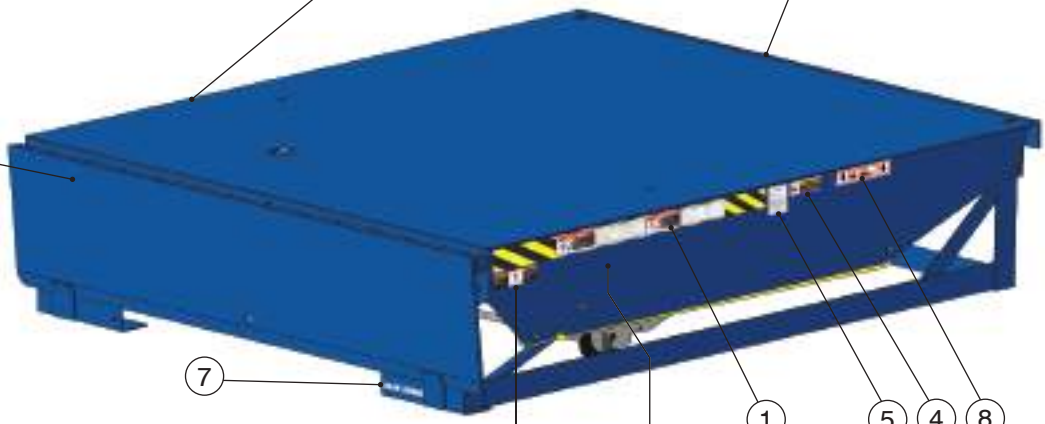
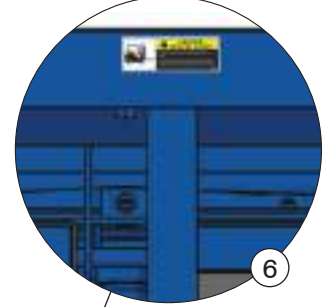
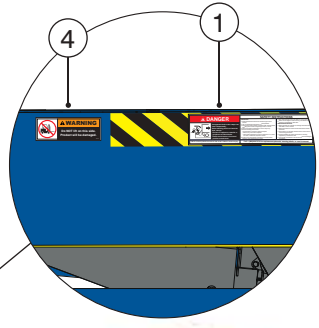
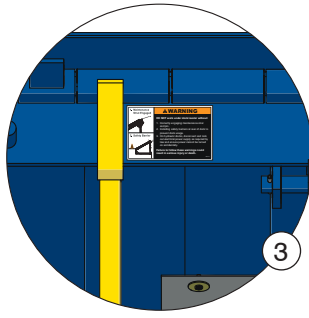

ITEM	QTY	PART NO.	DESCRIPTION
1	2	038-226	EF Danger Decal - Safety Instructions
			ES
2	2	038-220	EF Danger Decal - Do Not Walk on Lip
			ES
3	1	832-317	Warning Decal - Maintenance Strut
4	1	038-096	Warning Decal - Do Not Lift on This Side
5	2	108-120	EF Serial Plate Decal
			ES
6	1	038-098	EF Lift Caution Decal
			ES
7	1	038-017E	Blue Giant Logo Decal
8	1	038-1047E	Warning Decal - Do Not Lift

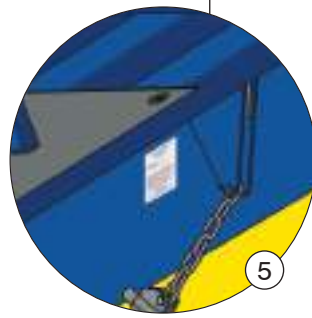

BLUE GIANT EQUIPMENT CORPORATION
 www.BlueGiant.com
 MADE IN CANADA

MODEL: AB006-30
 SERIAL NO.: 38750-01
 CAPACITY: 30,000 LBS / 13,638 KGS
 ELECTRICS: 115V / 1PH / 60HZ
 FALL SAFE CAP: 030215 (MM/YYYY)

MODIFICATIONS AND ADDITIONS WHICH AFFECT CAPACITY AND SAFE OPERATION SHALL NOT BE PERFORMED BY THE CUSTOMER OR USER WITHOUT THE MANUFACTURER'S PRIOR WRITTEN APPROVAL. CAPACITY, OPERATION AND MAINTENANCE INSTRUCTION PLATES, TAGS OR DECAL BE CHANGED ACCORDINGLY.

COMPLIES WITH ANSI MH26.1
 "REFER TO SAFETY AND OPERATING INSTRUCTIONS IN YOUR OWNERS MANUAL."

109-120E

EF = English / French | ES = English / Spanish

12.0 EQUIPMENT COMPONENT ILLUSTRATIONS

12.1 COMPONENTS AS SHIPPED CHECK LIST

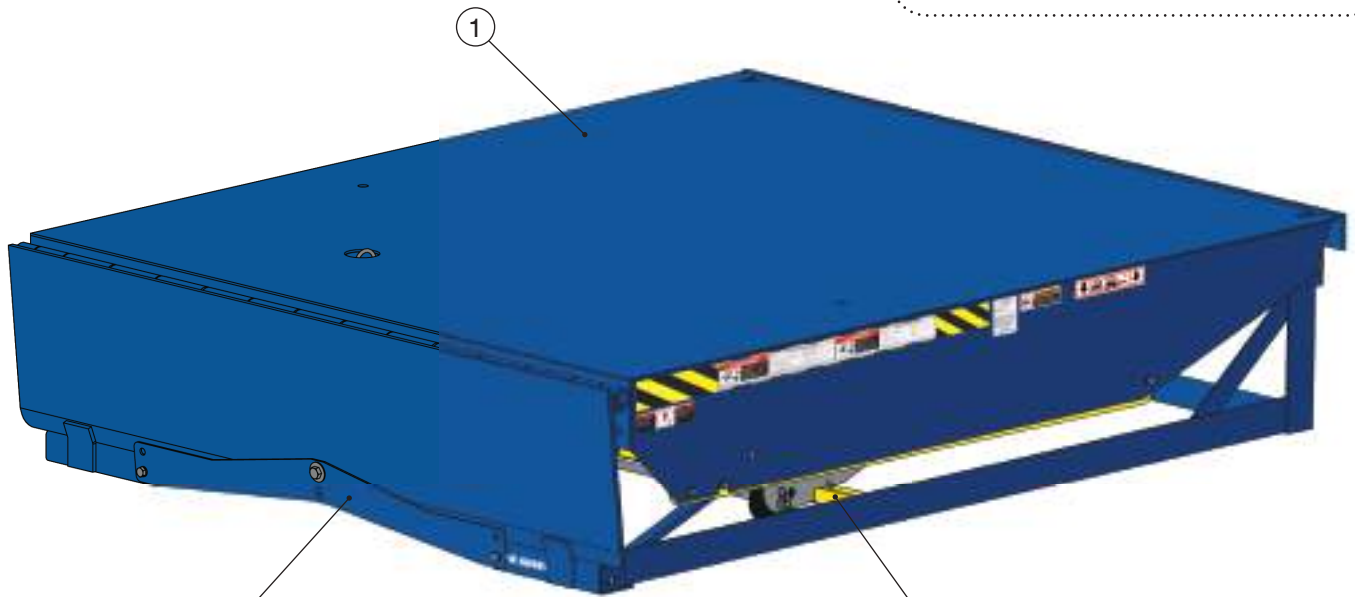
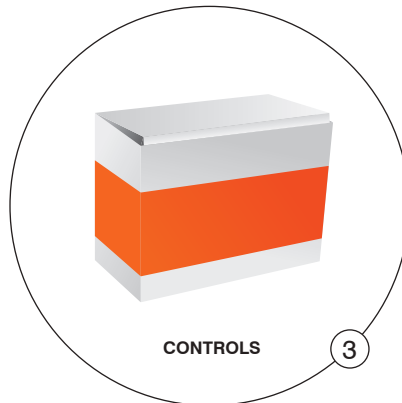
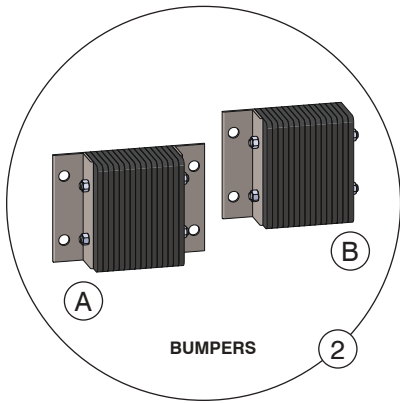

6 Shipping Bracket
(remove after installation)

Airbag Tray Tie Down
For Shipping Only
(remove prior to operation)

✓	ITEM	QTY	PART NO.	DESCRIPTION	APPROX. WEIGHT
	1	1	ABXXX-XX*	Air Bag Dock Leveler Air Bag Dock Leveler with DLB	*See Section 12.4 Varies by Model
	2	2	DB411	Laminated Bumper, Dual Flange	50 lb 23 kg
			DB411WB	Laminated Bumper, Single Flange	48 lb 22 kg
	3	1	027-006-L	F Control Assembly SP1 110-130V Single Phase S See Section 12.8	1 lb 0.45 kg
				F Control Assembly SP1 208-240V Single Phase S See Section 12.8	
	4	1	038-757E	Operation Placard	— —
	5	1	038-880E	Owner's Manual (this one)	— —
	6	1	26-013417	Shipping Bracket, Lip Tie Down	10 lb 4.5 kg

12.2 MECHANICAL ASSEMBLY

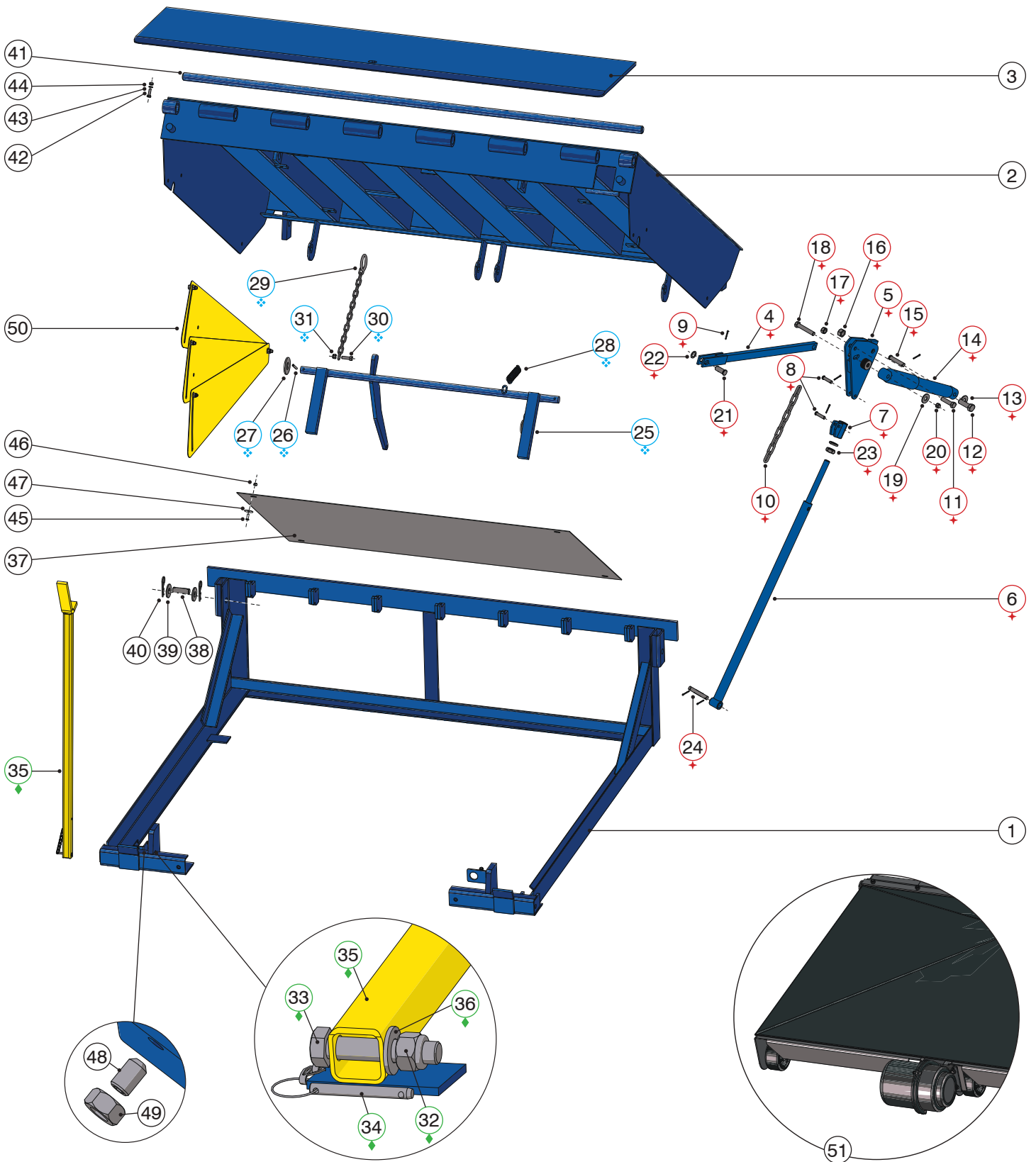

12.2 MECHANICAL ASSEMBLY

NOTE	DESCRIPTION	NOTE
+	Lip Deployment Assembly	Includes parts highlighted
❖	Fall Safe Legs Assembly	Includes parts highlighted

ITEM	QTY.	PART NO.	DESCRIPTION
1	1	See Section 12.6	Frame
2	1	See Section 12.4	Deck
3	1	See Section 12.5	Lip
+	4	26-011298	Push Rod
+	5	1001307	Link Plate Weldment w/ Shock 18-20" Lip
		1001307-1	Link Plate Weldment w/ Shock 16" Lip
+	6	26-011558	Lower Link Weldment
+	7	26-011555	Anchor Weldment
+	8	013-542	Clevis Pin
+	9	013-020	Cotter Pin
+	10	26-011305	Chain Assembly (6' L)
		26-011304	Chain Assembly (8' L)
			Chain Assembly (10' L)
+	11	011-032	HHCS 5/8" - 11 UNC x 2" GR.5
+	12	010-044	HHCS 1/2" - 13 UNC x 2"
+	13	012-679	Flat Spacer Washer 1/2"
+	14	200-02397	Shock Absorber
+	15	013-171	Clevis Pin 1/2" x 2 1/2"
+	16	011-621	Lock Nut 5/8" - 11 UNC
+	17	011-554	Nylon Insert Locknuts 1/2"-13 UNC
+	18	010-028	HHCS 1/2" - 13 UNC x 3"
+	19	012-212	Flat Washer 1/2"
+	20	011-552	Nylon Insert Locknuts 3/8" - 16 UNC
+	21	013-543	Clevis Pin 5/8" x 1-1/2"
+	22	012-275	Flat Spacer Washer (U.S.)
+	23A	011-530	Hex Jam Nut 3/4" - 10 UNC
+	23B	012-222	Locknut 3/4"
+	24	26-011551	Pin 5/8" x 3-1/2"
❖	25	26-011389	Fall Safe Legs (6' L, 8' L - 19" Frame)
		26-011389-1	Fall Safe Legs (10' L - 19" Frame)
❖	26	013-012	Spring Pin 1/4" x 2"

NOTE	DESCRIPTION	NOTE
◆	Maintenance Stand Assembly	Includes parts highlighted

ITEM	QTY.	PART NO.	DESCRIPTION
❖	27	012-250	Washer Flat USS 1-1/16"
❖	28	017-012	Tension Spring 4 1/2" L
❖	29	788-197-1	Pull Chain
❖	30	010-077	Cap Screw 3/8" - 16 x 1-1/4" HH GR.2
❖	31	011-552	Nylon Insert Locknuts 3/8" - 16 UNC
◆	32	011-554	Nylon Insert Locknuts 1/2" - 13 UNC
◆	33	010-027	HHCS 1/2" - 13 UNC x 2-1/2"
◆	34	013-510	Pin and Key Ring 1/4" x 1.8"
◆	35	26-011895-1	Safety Strut
◆	36	012-679	Washer Flat SAE 1/2 ZP
37	1	26-011308-1	Top Plate (6' L)
		26-011308	Top Plate (8' L)
		26-011308-2	Top Plate (10' L)
38	2	26-005610	Pin (Rear Fixed Hinge) 3/4" x 2-1/2"
39	4	012-214	Washer Flat USS 3/4"
40	4	013-029	Hairpin Cotter
41	1	109-699	Shaft (6' W)
		109-687-1	Shaft (6' 6" W)
		109-690	Shaft (7' W)
42	2	010-006	Cap Screw 5/16-18 x 1 HH GR.5 ZN
43	2	012-200	Regular Spring Lock Washers 5/16" (U.S.)
44	2	011-502	Hex Nuts 5/16"-18 (U.S.)
45	4	011-020	Philip Head Cap Screw 1/4"-20 x 3/4"
46	4	011-545	Nylon Insert Locknuts 1/4"-20NC
47	4	012-209	Washer Fender 1/4"
48	1	014-016	Setscrew Socket HD 5/16"-24 x 1/2"
49	1	011-518	Nuts Hex 5/16"-24 Plated
50	2	26-013420	Safety Skirt Package (6' L)
		26-013332	Safety Skirt Package (8' L)
		26-013571	Safety Skirt Package (10' L)
51	1	See Section 12.3	Air Bag and Platform Assembly

12.3 AIRBAG AND PLATFORM ASSEMBLY

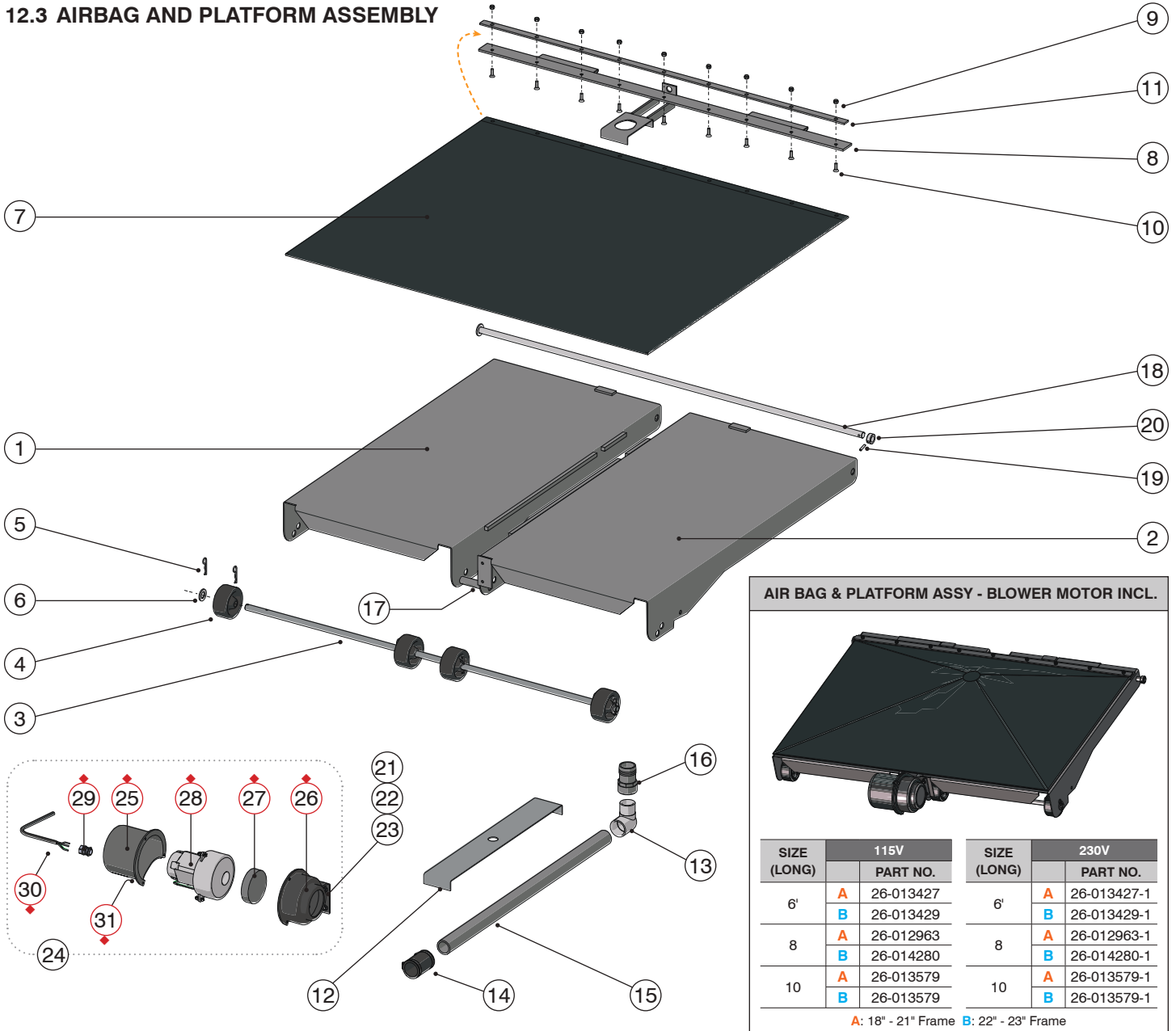

AIR BAG & PLATFORM ASSY - BLOWER MOTOR INCL.

SIZE (LONG)	115V		230V		
	SIZE (LONG)	PART NO.	SIZE (LONG)	PART NO.	
6'	A	26-013427	6'	A	26-013427-1
	B	26-013429		B	26-013429-1
8	A	26-012963	8	A	26-012963-1
	B	26-014280		B	26-014280-1
10	A	26-013579	10	A	26-013579-1
	B	26-013579		B	26-013579-1

A: 18" - 21" Frame B: 22" - 23" Frame

ITEM	QTY.	PART NO.	DESCRIPTION	ITEM	QTY.	PART NO.	DESCRIPTION	ITEM	QTY.	PART NO.	DESCRIPTION	
1	1	26-013425-1	LH Platform	6' L	11	26-011267	Airbag Clamp Bar	23	2	011-545	Nylon Insert Locknuts 1/4" - 20NC	
		26-013001-1		8' L		26-012978-2	Connector					
		26-013577		10' L		26-012978-1	Reinforce Bracket	24	1	26-012925	Blower Motor Assy 115V / 1PH / 60Hz	
2	1	26-013426-1	RH Platform	6' L	26-012978-3	10' L	26-012925-1				Blower Motor Assy 230V / 1PH / 60Hz	
		26-013002-1		8' L	13	1	035-096	Elbow Fitting w/Barb				
		26-013578		10' L					14	1	26-004820	Flex Pipe Coupling
3	1	26-011266-1	Wheels Axis	15	1	091-958-0254	Pipe	6' L				
4	4	020-018	Wheel			091-958-0370			8' L			
5	6	013-028	Hairpin Cotter			091-958-0440			10' L			
6	2	012-266	Washer Flat SAE 3/4" ZP	16	1	034-004	Straight Barb	28	1	031-033	Motor	
7	1	26-013413	Air Bag	6' L	17	1	090-385-0040					Tube 3/4" x 4"
		26-012962		8' L				18	1	26-013333	Rear Hinge Pin	
		26-013389		10' L	19	1	013-009					Spring Pin 1/4" D x 1" L
8	1	26-012961	Hook Plate	20	1	26-013415	Collar	28	1	090-T12-2	Ground Wire Assy ¹	
9	9	011-543	Nylon Insert Locknuts 5/16"-18	21	2	010-001	Cap Screw 1/4-20 x 1 HH					28
10	9	011-042	Capscrew Hex Socket 5/16"-18x1"	19	1	013-009	Spring Pin 1/4" D x 1" L	28	1	025-015	Cable Gland	
11	1	26-011267	Airbag Clamp Bar	6' L	20	1	26-013415					Collar
				8' L				21	2	010-001	Cap Screw 1/4-20 x 1 HH	
12	1	26-012978-2	Connector	6' L	22	2	012-210	Washer Flat USS 1/4 ZP	28	3	011-545	Nylon Insert Locknuts ¹
				8' L								
13	1	035-096	Elbow Fitting w/Barb	6' L	22	2	012-210	Washer Flat USS 1/4 ZP	28	3	011-545	Nylon Insert Locknuts ¹
				8' L								
14	1	26-004820	Flex Pipe Coupling	6' L	22	2	012-210	Washer Flat USS 1/4 ZP	28	3	011-545	Nylon Insert Locknuts ¹
				8' L								
15	1	091-958-0254	Pipe	6' L	22	2	012-210	Washer Flat USS 1/4 ZP	28	3	011-545	Nylon Insert Locknuts ¹
				8' L								
				10' L								
16	1	034-004	Straight Barb	6' L	22	2	012-210	Washer Flat USS 1/4 ZP	28	3	011-545	Nylon Insert Locknuts ¹
				8' L								
17	1	090-385-0040	Tube 3/4" x 4"	6' L	22	2	012-210	Washer Flat USS 1/4 ZP	28	3	011-545	Nylon Insert Locknuts ¹
				8' L								
18	1	26-013333	Rear Hinge Pin	6' L	22	2	012-210	Washer Flat USS 1/4 ZP	28	3	011-545	Nylon Insert Locknuts ¹
				8' L								
19	1	013-009	Spring Pin 1/4" D x 1" L	6' L	22	2	012-210	Washer Flat USS 1/4 ZP	28	3	011-545	Nylon Insert Locknuts ¹
				8' L								
20	1	26-013415	Collar	6' L	22	2	012-210	Washer Flat USS 1/4 ZP	28	3	011-545	Nylon Insert Locknuts ¹
				8' L								
21	2	010-001	Cap Screw 1/4-20 x 1 HH	6' L	22	2	012-210	Washer Flat USS 1/4 ZP	28	3	011-545	Nylon Insert Locknuts ¹
				8' L								
22	2	012-210	Washer Flat USS 1/4 ZP	6' L	22	2	012-210	Washer Flat USS 1/4 ZP	28	3	011-545	Nylon Insert Locknuts ¹
				8' L								

¹ = Not visible on drawing

12.4 DECK SIZE AND CAPACITIES

DECK SIZE (NOMINAL)	CAPACITY		MODEL	PART NO.	
				AB	AB with DLB
6' x 6'	30,000 lb	13,636 kg	AB6006-30	26-013302	26-013862
	35,000 lb	15,909 kg	AB6006-35	26-013423	26-013862-1
	40,000 lb	18,144 kg	AB6006-40	26-013424	26-013862-2
	45,000 lb	20,454 kg	AB6006-45	26-013424	26-013862-2
6' x 8'	30,000 lb	13,636 kg	AB6008-30	26-013419	26-013862-5
	35,000 lb	15,909 kg	AB6008-35	26-013418	26-013862-3
	40,000 lb	18,144 kg	AB6008-40	26-013301	26-013862-4
	45,000 lb	20,454 kg	AB6008-45	26-013301	26-013862-4
6' x 10'	30,000 lb	13,636 kg	AB6010-30	26-013574	26-013862-6
	35,000 lb	15,909 kg	AB6010-35	26-013581	26-013862-7
	40,000 lb	18,144 kg	AB6010-40	26-013584	26-013862-8
	45,000 lb	20,454 kg	AB6010-45	26-013584	26-013862-8
6' 6" x 6'	30,000 lb	13,636 kg	AB6606-30	26-013302-1	26-014001
	35,000 lb	15,909 kg	AB6606-35	26-013423-1	26-014001-1
	40,000 lb	18,144 kg	AB6606-40	26-013424-1	26-014001-2
	45,000 lb	20,454 kg	AB6606-45	26-013424-1	26-014001-2
6' 6" x 8'	30,000 lb	13,636 kg	AB6608-30	26-013419-1	26-014001-5
	35,000 lb	15,909 kg	AB6608-35	26-013418-1	26-014001-3
	40,000 lb	18,144 kg	AB6608-40	26-013301-1	26-014001-4
	45,000 lb	20,454 kg	AB6608-45	26-013301-1	26-014001-4
6' 6" x 10'	30,000 lb	13,636 kg	AB6610-30	26-013580	26-014001-6
	35,000 lb	15,909 kg	AB6610-35	26-013582	26-014001-7
	40,000 lb	18,144 kg	AB6610-40	26-013585	26-014001-8
	45,000 lb	20,454 kg	AB6610-45	26-013585	26-014001-8
7' x 6'	30,000 lb	13,636 kg	AB7006-30	26-013302-2	26-013868
	35,000 lb	15,909 kg	AB7006-35	26-013423-2	26-013868-1
	40,000 lb	18,144 kg	AB7006-40	26-013424-2	26-013868-2
	45,000 lb	20,454 kg	AB7006-45	26-013424-2	26-013868-2
7' x 8'	30,000 lb	13,636 kg	AB7008-30	26-013419-2	26-013868-5
	35,000 lb	15,909 kg	AB7008-35	26-013418-2	26-013868-3
	40,000 lb	18,144 kg	AB7008-40	26-013301-2	26-013868-4
	45,000 lb	20,454 kg	AB7008-45	26-013301-2	26-013868-4
7' x 10'	30,000 lb	13,636 kg	AB7010-30	26-013575	26-013868-6
	35,000 lb	15,909 kg	AB7010-35	26-013583	26-013868-7
	40,000 lb	18,144 kg	AB7010-40	26-013586	26-013868-8
	45,000 lb	20,454 kg	AB7010-45	26-013586	26-013868-8

12.5 LIP SIZE AND CAPACITIES

DECK WIDTH	CAPACITY		LENGTH		PART NO.		
	LB	KG			AB	AB with DLB	
6'	30,000	13,636	16"	406mm	26-011387	26-013861-2	
			18"	457mm	26-011387-1	26-013861-5	
			20"	508mm	26-011387-2	26-013861-8	
	35,000	15,909	16"	406mm	26-011535-3	26-013861-1	
			18"	457mm	26-011535-1	26-013861-3	
			20"	508mm	26-011535-2	26-013861-6	
	40,000 to 45,000	18,144 to 20,454	16"	406mm	26-011535	26-013861	
			18"	457mm	26-011535-1	26-013861-3	
			20"	508mm	26-011535-2	26-013861-6	
	6' 6"	30,000	13,636	16"	406mm	26-011533	26-013869-2
				18"	457mm	26-011533-1	26-013869-5
				20"	508mm	26-011533-2	26-013869-8
35,000		15,909	16"	406mm	26-011536-3	26-013869-1	
			18"	457mm	26-011536-1	26-013869-3	
			20"	508mm	26-011536-2	26-013869-6	
40,000 to 45,000		18,144 to 20,454	16"	406mm	26-011536	26-013869	
			18"	457mm	26-011536-1	26-013869-3	
			20"	508mm	26-011536-2	26-013869-6	
7'		30,000	13,636	16"	406mm	26-011296	26-013870-2
				18"	457mm	26-011296-1	26-013870-5
				20"	508mm	26-011296-2	26-013870-8
	35,000	15,909	16"	406mm	26-011537-3	26-013870-1	
			18"	457mm	26-011537-1	26-013870-3	
			20"	508mm	26-011537-2	26-013870-6	
	40,000 to 45,000	18,144 to 20,454	16"	406mm	26-011537	26-013870	
			18"	457mm	26-011537-1	26-013870-3	
			20"	508mm	26-011537-2	26-013870-6	

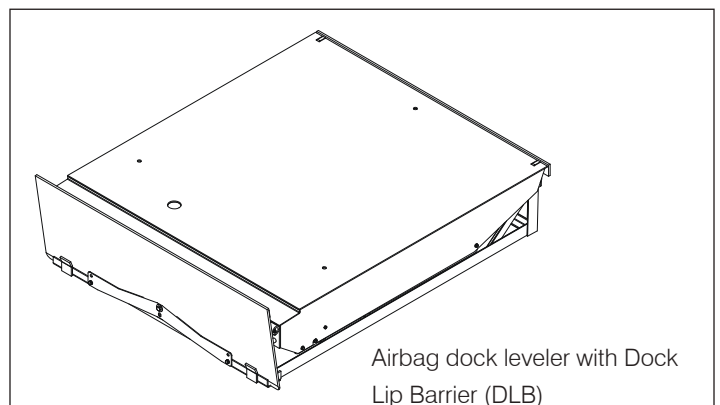

12.6 FRAME SIZE

DECK SIZE (NOMINAL)	LENGTH		PART NO.	
			AB	AB with DLB
6' x 6'			AB6006	
	16"	406mm	26-011887-1	26-013863-1
	18"	457mm	26-011887-5	26-013863-5
	20"	508mm	26-011887-3	26-013863-3
6' x 8'			AB6008	
	16"	406mm	26-011887	26-013863
	18"	457mm	26-011887-4	26-013863-4
	20"	508mm	26-011887-2	26-013863-2
6' x 10'			AB6010	
	16"	406mm	26-011539	26-013867
	18"	457mm	26-011539-1	26-013867-1
	20"	508mm	26-011539-2	26-013867-2
6' 6" x 6'			AB6606	
	16"	406mm	26-011888-1	26-013994-1
	18"	457mm	26-011888-5	26-013994-5
	20"	508mm	26-011888-3	26-013994-3
6' 6" x 8'			AB6608	
	16"	406mm	26-011888	26-013994
	18"	457mm	26-011888-4	26-013994-4
	20"	508mm	26-011888-2	26-013994-2

DECK SIZE (NOMINAL)	LENGTH		PART NO.	
			AB	AB with DLB
6' 6" x 10'			AB6610	
	16"	406mm	26-011559	26-013998
	18"	457mm	26-011559-1	26-013998-1
	20"	508mm	26-011559-2	26-013998-2
7' x 6'			AB7006	
	16"	406mm	26-011889-1	26-013995-1
	18"	457mm	26-011889-5	26-013995-5
	20"	508mm	26-011889-3	26-013995-3
7' x 8'			AB7008	
	16"	406mm	26-011889	26-013995
	18"	457mm	26-011889-4	26-013995-4
	20"	508mm	26-011889-2	26-013995-2
7' x 10'			AB7010	
	16"	406mm	26-011560	26-013999
	18"	457mm	26-011560-1	26-013999-1
	20"	508mm	26-011560-2	26-013999-2

12.7 STANDARD PIT DIMENSIONS

NOMINAL SIZE		PIT WIDTH (W)		PIT LENGTH (L)	
		in	mm	in	mm
6' x 6'	1829 x 1829mm	74	1880	61.25	1556
6' x 8'	1829 x 2438mm			85.25	2165
6' x 10'	1829 x 3048mm			109.25	2775
6' 6" x 6'	1981 x 1829mm	80	2032	61.25	1556
6' 6" x 8'	1981 x 2438mm			85.25	2165
6' 6" x 10'	1981 x 3048mm			109.25	2775
7' x 6'	2133 x 1829mm	85	2159	61.25	1556
7' x 8'	2133 x 2438mm			85.25	2165
7' x 10'	2133 x 3048mm			109.25	2775

Lip Length:	16", 18", 20" (406, 457, 508mm)	
Standard Frame Depth:	Front: 19.5" (495mm)	Rear: 19" (483mm)
Standard Pit Depth:	Front (H): 20" (508mm)	Rear (H1): 19.5" (495mm)

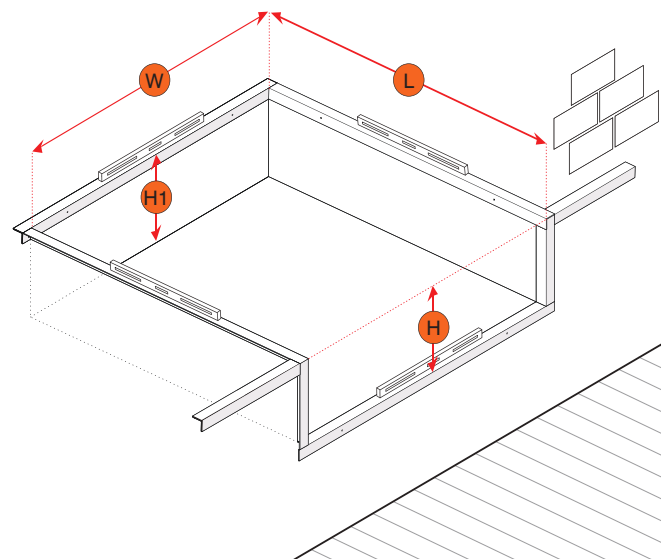

- Alternatives available:**
- Longer filler
 - Deeper pits
 - Other options – consult factory

12.8 CONTROLS

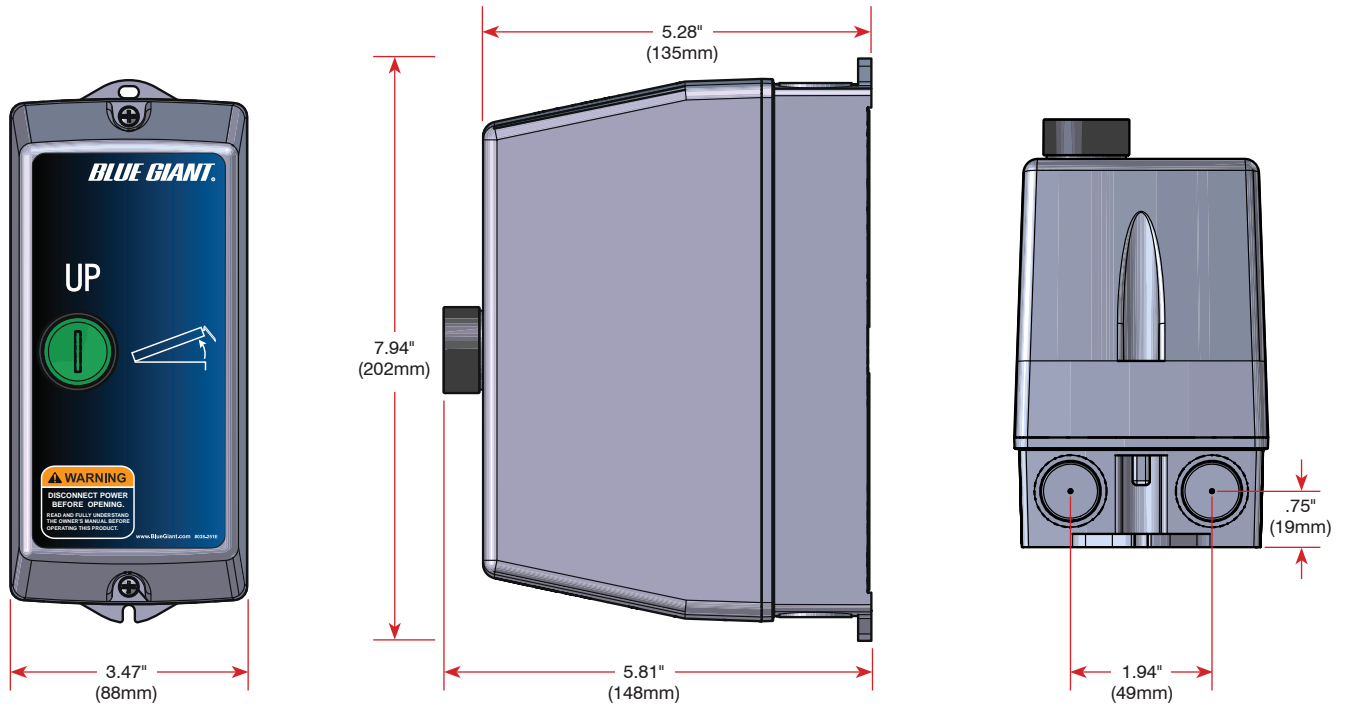

Front View

Side View

Bottom View

COMPLETE CONTROL STATION SINGLE PUSH BUTTON SP1

ITEM	SINGLE PHASE			
	QTY	PART NO.	DESCRIPTION	VOLTAGE RANGE
1	1	027-006-L	115V / 1PH / 50-60 Hz	110 - 130V
	1	027-007-L	230V / 1PH / 50-60Hz	208 - 240V

Decal included (part # 038-251E)

COMPLETE CONTROL STATION SINGLE PUSH BUTTON SP1 WITH OVERLOAD

ITEM	SINGLE PHASE			
	QTY	PART NO.	DESCRIPTION	VOLTAGE RANGE
1	1	027-006-LO	115V / 1PH / 50-60 Hz	110 - 130V
	1	027-007-LO	230V / 1PH / 50-60Hz	208 - 240V

Decal included (part # 038-251E)

13.0 DOCK LEVELER TROUBLESHOOTING

⚠	WARNING
<p>Do not attempt to install, make repairs or adjustments. Only a trained and authorized service technician should perform the installation process. Contact your local dealer or distributor for assistance.</p>	

PROBLEM	PROBLEM CAUSE
Deck will not raise.	<ol style="list-style-type: none"> 1. The blower motor may have failed or been mis-wired. Repair or replace as necessary. In the case of potential mis-wiring, please consult wiring diagram shipped with unit. 2. The control station is not functioning properly. Replace if necessary. 3. Overload relay (optional) may have been tripped. If applicable, investigate and reset. 4. Air bag may have been damaged. Inspect and repair if required. 5. Main power feed may be disconnected or a fuse may have blown. Reconnect power and inspect fuses. 6. Blower intake may be blocked. Check and clean if necessary.
Deck will not lower.	<ol style="list-style-type: none"> 1. Debris may have accumulated under the platform. Remove and clean around the pit area. 2. Maintenance stand may still be engaged. Investigate and disengage. 3. Blower intake may be blocked. Check and clean if necessary.
Deck raises slowly.	<ol style="list-style-type: none"> 1. Air bag may be damaged. Inspect and repair as required. 2. Cargo and other weight sources may be sitting on the deck. Check and remove if necessary. 3. Blower intake may be blocked. Check and clean if necessary. 4. Blower uncoupled from bag. Check and call for service. 5. Inadequate voltage. Check line voltage.
The lip will not extend.	<ol style="list-style-type: none"> 1. Debris may be in the lip hinge. Check the hinge and clean away any dirt or corrosion. 2. Lip deployment mechanism may be damaged. Check and replace if necessary. 3. Damaged air bag. 4. Blower uncoupled from bag. Check and call for service. 5. Incorrect voltage. Check line voltage relative to blower motor voltage.
The lip remains in the extended position.	<ol style="list-style-type: none"> 1. Lip may be bent or damaged. Apply lubrication, and if necessary replace the lip. 2. The lip deployment mechanism may be damaged. Conduct any necessary repairs and replace parts as needed. 3. Debris may have collected in the lip hinge. Clean and lubricate.
The lip strikes the rear of the truck as the deck raises, stops, or slows down, and lip does not extend in the locked position.	<ol style="list-style-type: none"> 1. Damaged or missing dock bumpers allow the truck to park too close to the leveler. 2. Height difference between the dock and truck bed may be greater than recommended 3. The lip actuator assembly may be damaged, causing lip to begin extending too early in the cycle. Adjust as necessary. 4. <u>The lip actuator requires adjustment.</u>

14.1 SP1 WIRING DIAGRAM—110-130V SINGLE PHASE

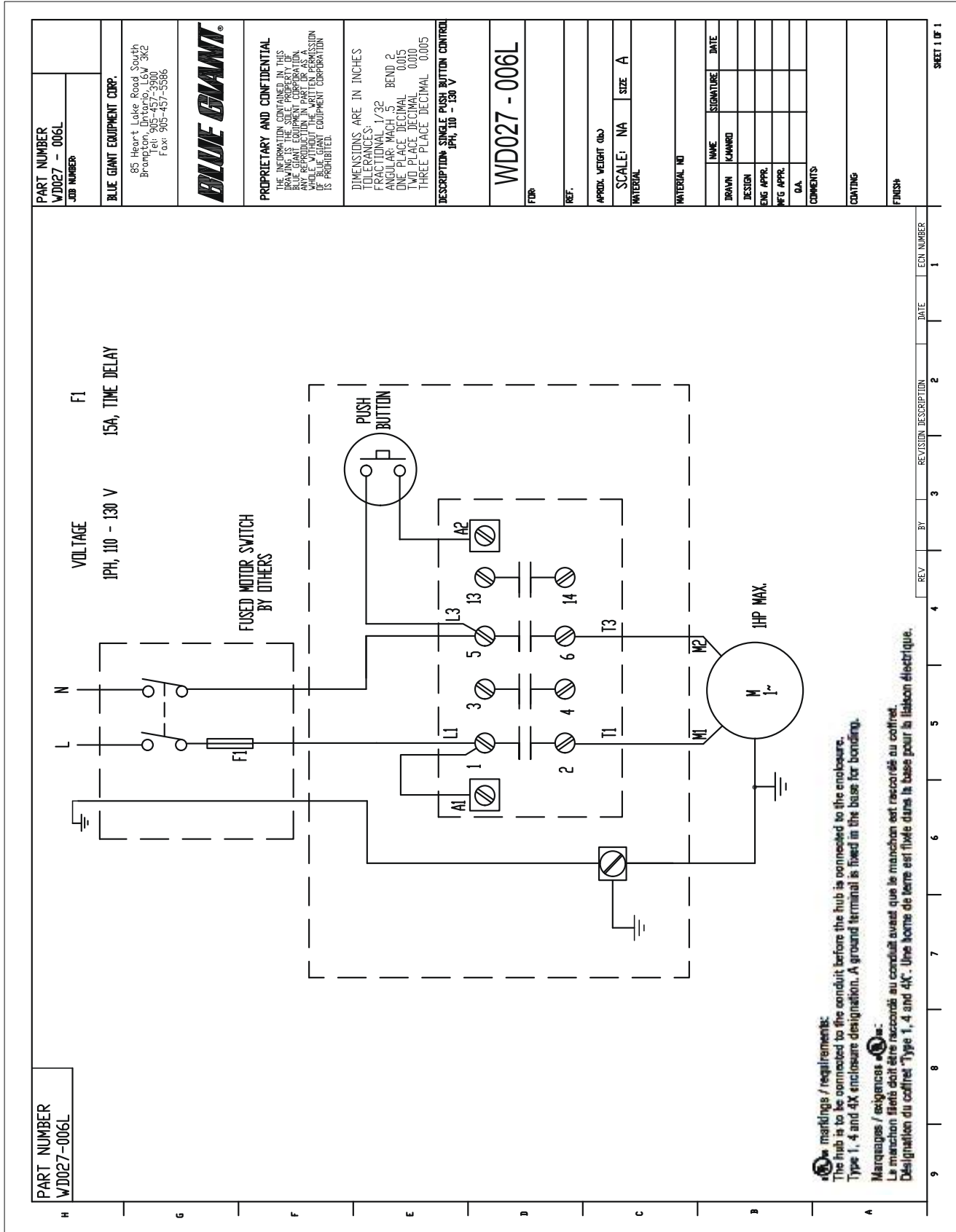

PART NUMBER WD027 - 006L	
JOB NUMBER:	
BLUE GIANT EQUIPMENT CORP.	
85 Heart Lake Road South Brompton Ontario L6V 3K2 Tel: 905-457-5586 Fax: 905-457-5586	
BLUE GIANT®	
PROPRIETARY AND CONFIDENTIAL THE INFORMATION CONTAINED IN THIS DRAWING IS THE SOLE PROPERTY OF BLUE GIANT EQUIPMENT CORPORATION. ANY REPRODUCTION IN PART OR AS A WHOLE WITHOUT THE WRITTEN PERMISSION OF BLUE GIANT EQUIPMENT CORPORATION IS PROHIBITED.	
DIMENSIONS ARE IN INCHES TOLERANCES: FRACTIONAL: 1/32 BEND 2 ANGULAR: MACH .5 ONE PLACE DECIMAL .005 TWO PLACE DECIMAL .000 THREE PLACE DECIMAL .0005	
DESCRIPTION: SINGLE PUSH BUTTON CONTROL 1PH, 110 - 130 V	
WD027 - 006L	
FUR:	
REF:	
APPROX. WEIGHT (lb):	
SCALE: NA SIZE A	
MATERIAL:	
MATERIAL NO:	
NAME	SIGNATURE
DRAWN	DATE
DESIGN	
ENG APPR.	
MFG APPR.	
QA	
COMMENTS	
CURTING	
FINISH	

SHEET 1 OF 1

14.2 SP1 WIRING DIAGRAM—208-240V SINGLE PHASE

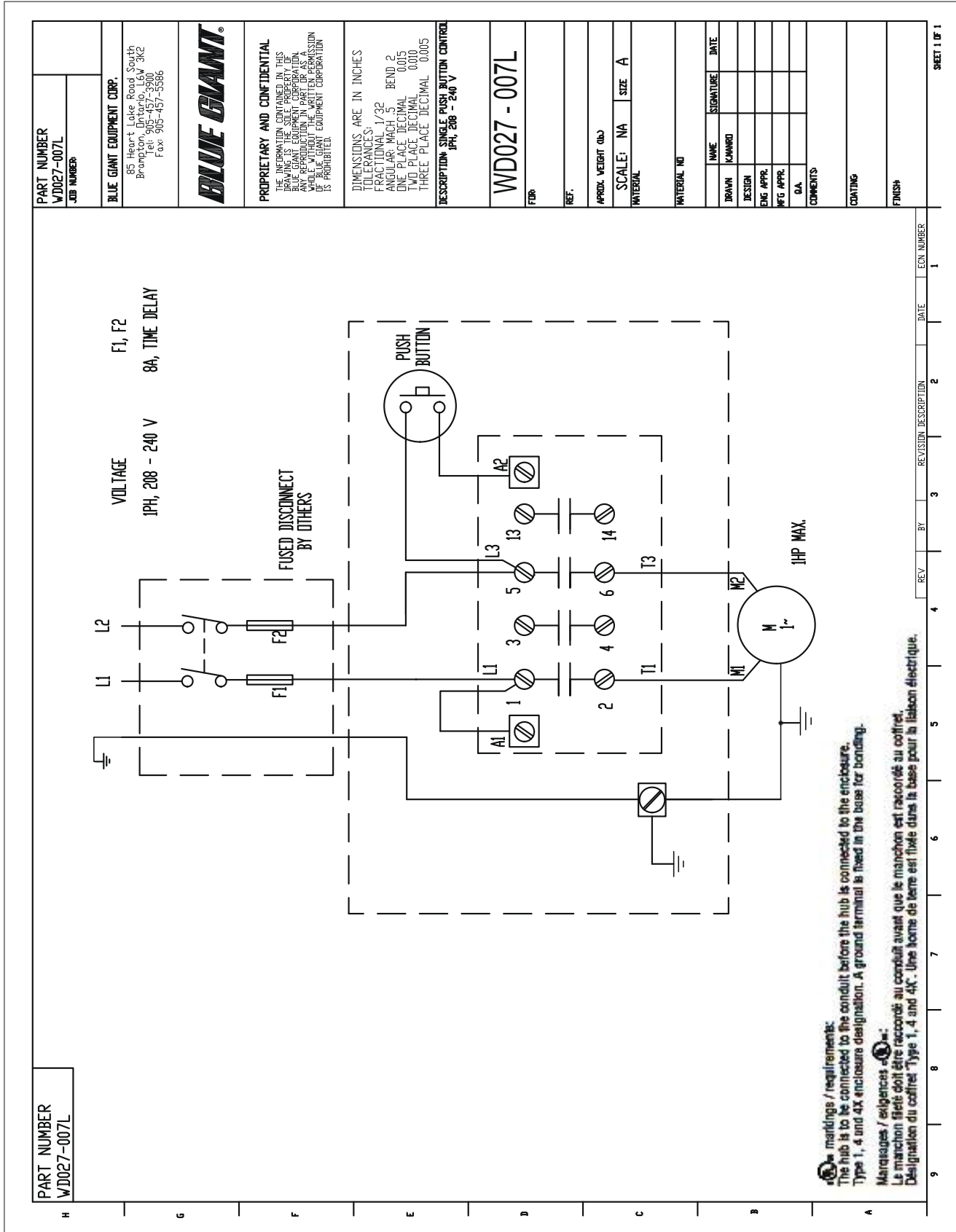

15.0 ALTERNATIVE CONTROL STATION OPTIONS

Control station upgrades are available for enhanced equipment operation.

The SP2 controls an independent dock leveler via a constant pressure “I” (UP) button and has a running timer that shuts down the motor after a specific interval to prevent excessive motor activity. Overhead door interlock provision terminals protect door from incorrect leveler sequence.

The Blue Genius™ Gold Series I is a microprocessor-based control station with a touch-sensitive ‘Deck’ button and numeric keypad. The LED menu screen relays real-time prompts and commands for operating and troubleshooting. For added safety, the Blue Genius™ is available with an optional interior and exterior light communication package, overhead door interlock and expansion capability for future vehicle restraint and overhead door buttons.



SP2 Control



Blue Genius™ Gold Series I

15.1 SP2 CONTROLS

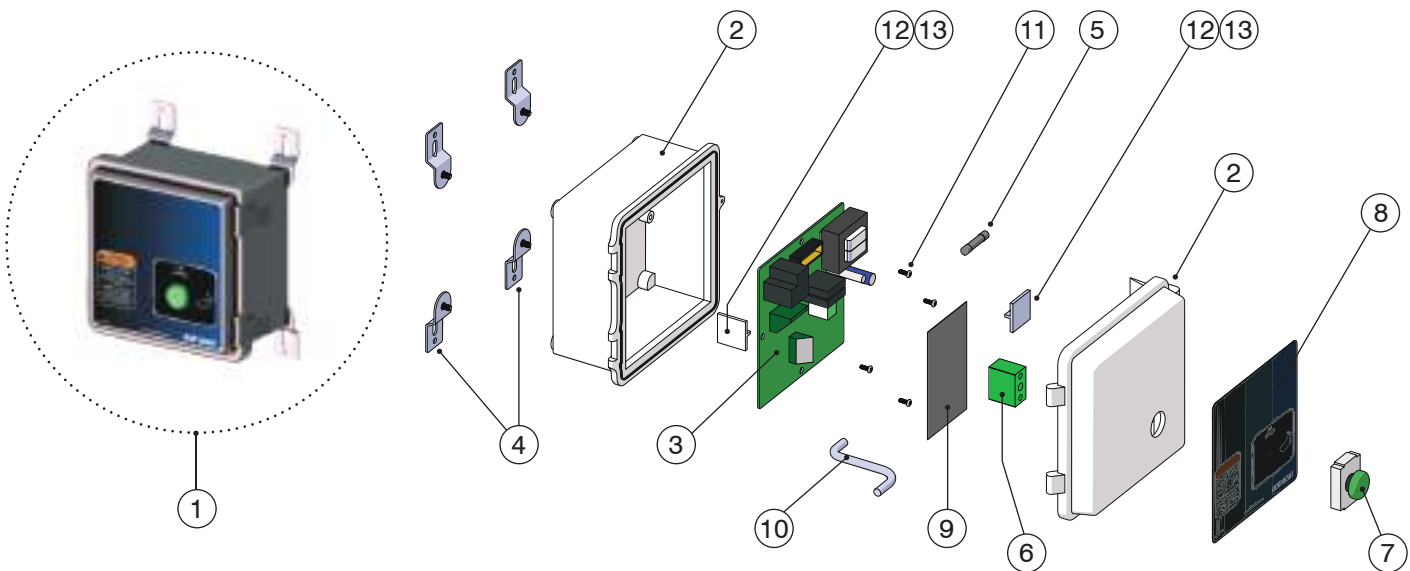

ITEM	QTY.	PART NO.	DESCRIPTION	
1	1	SP2S1115	F	SP2 Control Assembly 115V Single Phase
			S	
		SP2S1230	F	SP2 Control Assembly 230V Single Phase
			S	
2	1	025-G023-4M	Control Box Enclosure	
3	1	026-G054-M	Power Circuit Board - SP2, 1PH STD	
4	4	025-G010-1	Mounting Tabs w/Screws	
5	1	026-G121	Fuse F.A. 100mA, 250V 5 x 20mm	
6	1	026-G202	Button Contact Block N/O	

ITEM	QTY.	PART NO.	DESCRIPTION
7	1	028-573	Green Push Button w/Mounting Collar
8	1	038-266EF	Decal, English / French
		038-266ES	Decal, English / Spanish
9	1	038-284EF	Decal, Serial Plate / French
		038-284ES	Decal, Serial Plate / Spanish
10	1	026-G035	3 Wire Cable
11	4	010-216	Screw, M4 x 8 Pan Phil
12	2	025-062	Cable Tie Mount
13	2	522-008	Ties, Wire YS-98C

15.2 BLUE GENIUS™ CONTROLS

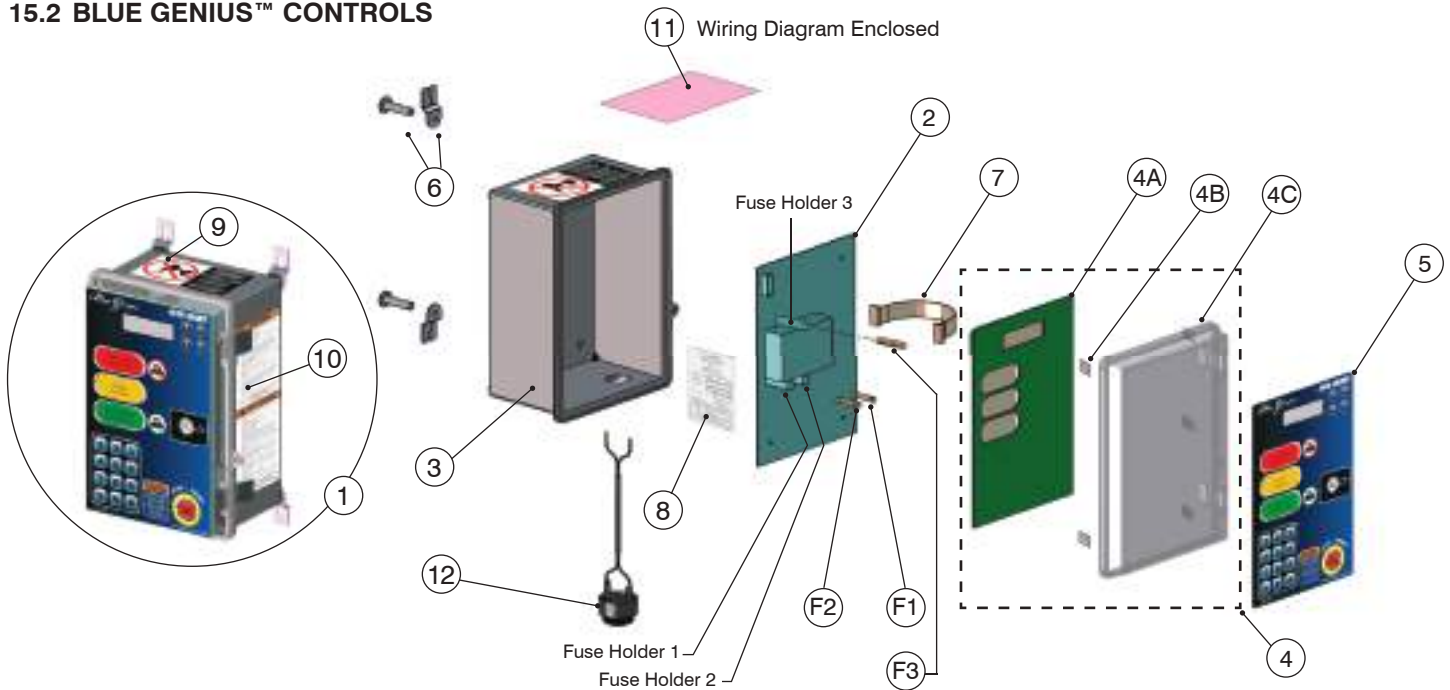

COMPLETE CONTROL STATION ASSEMBLY - ITEM 1 (Example BGGE01115F)

COMPLETE CONTROL STATION ASSEMBLY - ITEM 1 (Example BGGE01115F)							
ITEM	SINGLE PHASE						
	◇	FUSE	QTY	PART NO.	DESCRIPTION	ASSY PART #	*
2		F1	B	1	026-PB1115	Power Board Sub-Assembly † (1PH 115V 50-60HZ)	F
		F2	A	1			S
		F1	C	1	026-PB1230	Power Board Sub-Assembly † (1PH 230V 50-60HZ)	F
		F2		1			S
3			1	025-G010-M	Control Box Enclosure (Includes 4C)		
4			1	025-G014-V3-M	Transparent Cover Door (4C) and Touch Control Board (4A) (Serial # Required)		
4A			1	026-G021-M	Touch Control Board (Serial # Required)		
4B			5	025-062	Cable Tie Mount		
4C			1	025-G014	Transparent Cover Door		
5			1	038-259E	Button Decal	F	
						S	
6			1	025-G010-1	Mounting Tabs with Hardware (1 pkg of 4)		

* Language on decal: F = English / French S = English / Spanish

◇ Location on Power Board † Includes Fuses ‡ 115 Volt Control Box Shown

ITEM	QTY	PART NO.	DESCRIPTION
7	1	026-G030	Ribbon Cable
8	1	038-284E	F
			S
9	1	038-283EFS	Decal, Serial Plate
10	1	038-853E	F
			S
11	1	026-615-1	Anti-Static Poly Bag (Wiring Diagram Enclosed) (Serial # required for diagram)
12	1	026-G402	Audible Speaker
F3	1	026-037-1	Fuse, 2.5A, 700V, Fast-Blow 1/4" Glass

AS PER VOLTAGE - SEE ITEM 1

ITEM	QTY	PART NO.	DESCRIPTION
B	1	026-G101	Fuse, 8A, 250V, Time Delay for 1PH, 208-240V
C	1	026-G102	Fuse, 0.5A, 250V, Time Delay for 1 and 3PH, 208-240V
E	1	026-G104	Fuse, 0.75A, 250V, Time Delay for 1PH, 110-130V

15.3 BLUE GENIUS™ CONTROLS WIRING DIAGRAMS

NOTICE

The following wiring diagrams are sample configurations only. Wiring diagrams specific to your needs will be provided inside the control panel and/or as part of your submittal package.

15.4 SP2 WIRING DIAGRAM—115V SINGLE PHASE

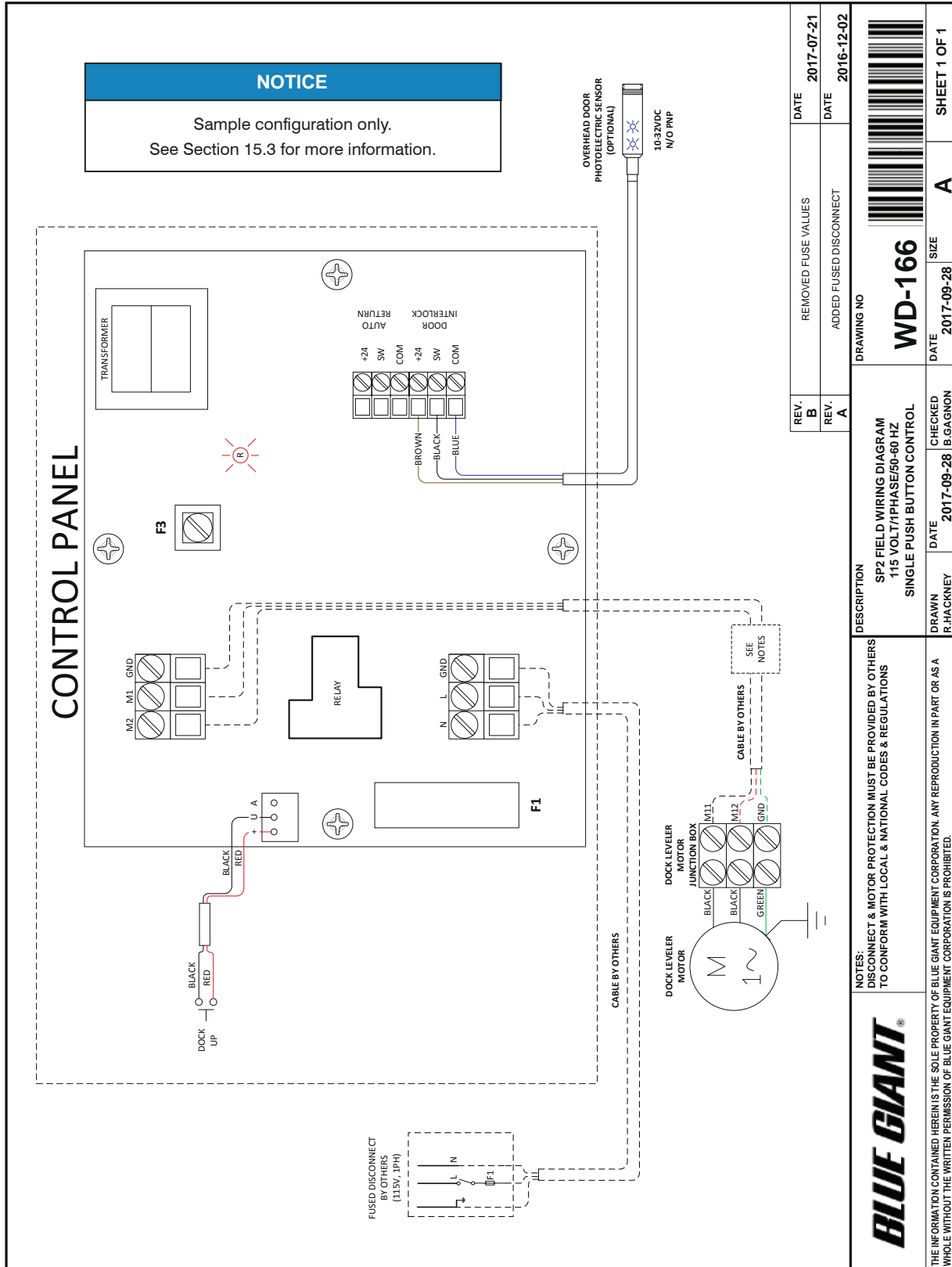

15.5 SP2 WIRING DIAGRAM—230V SINGLE PHASE

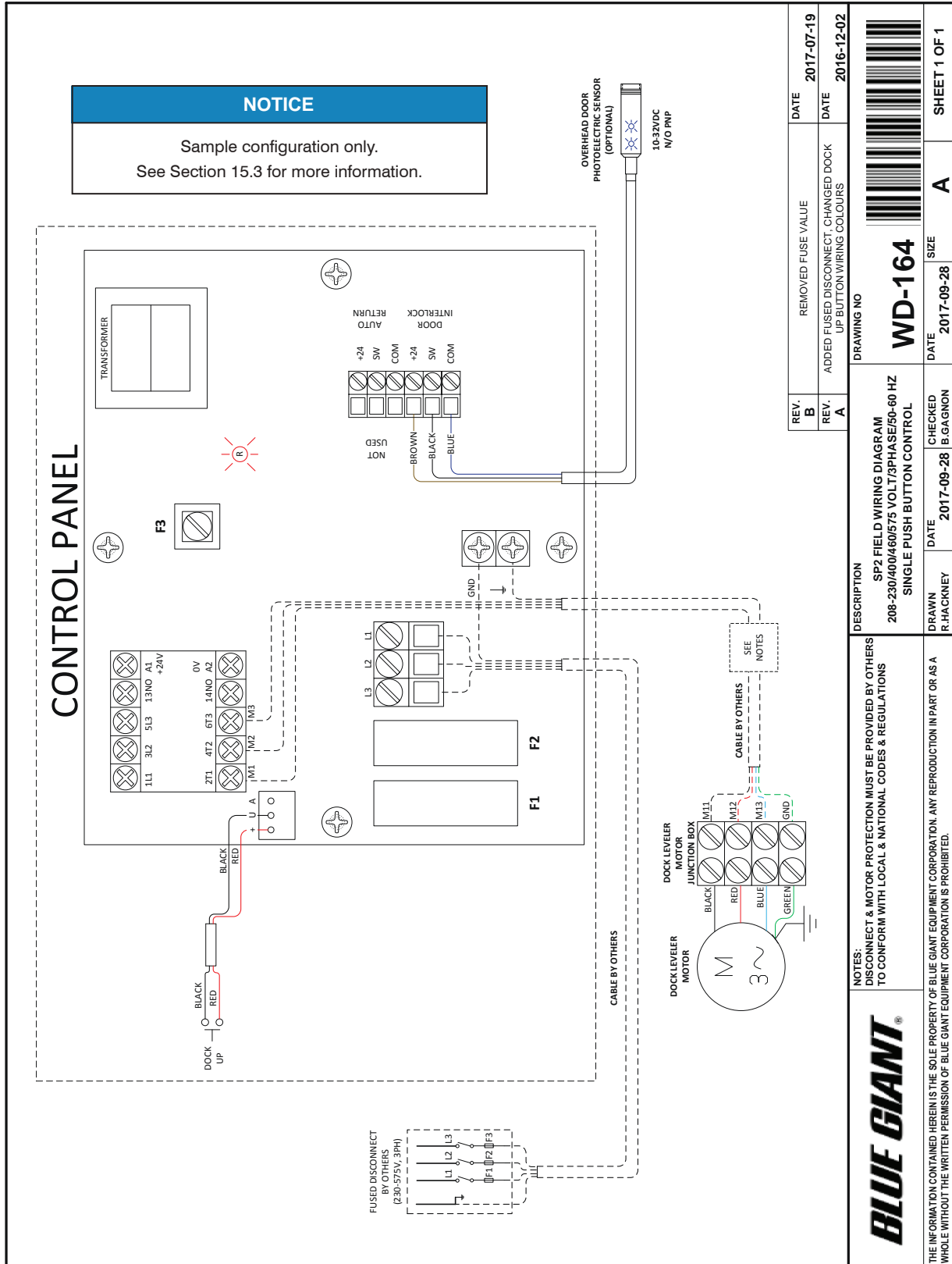

15.6 BLUE GENIUS™ GOLD WIRING DIAGRAM—115V SINGLE PHASE

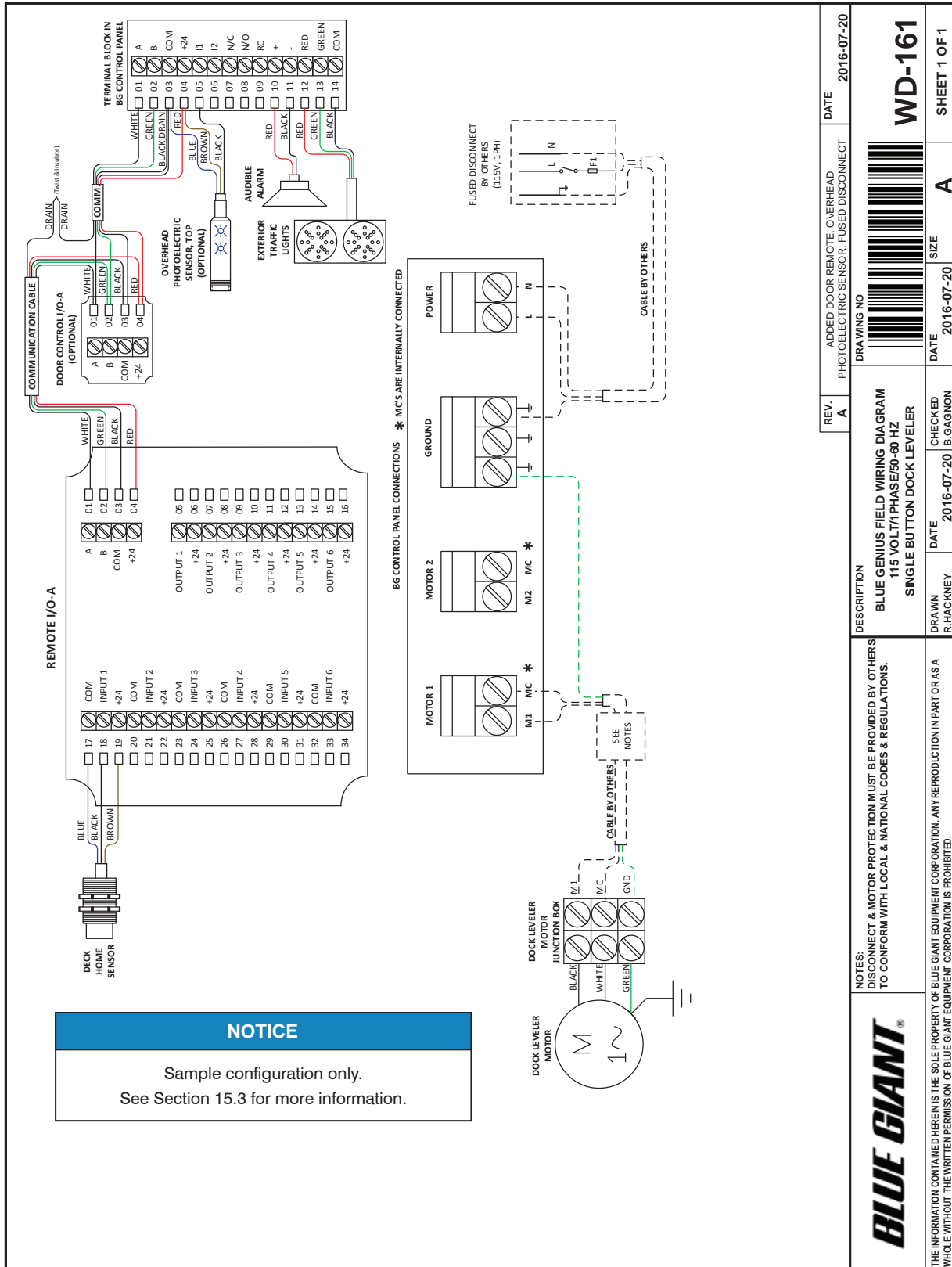

15.7 BLUE GENIUS™ GOLD WIRING DIAGRAM—230V SINGLE PHASE

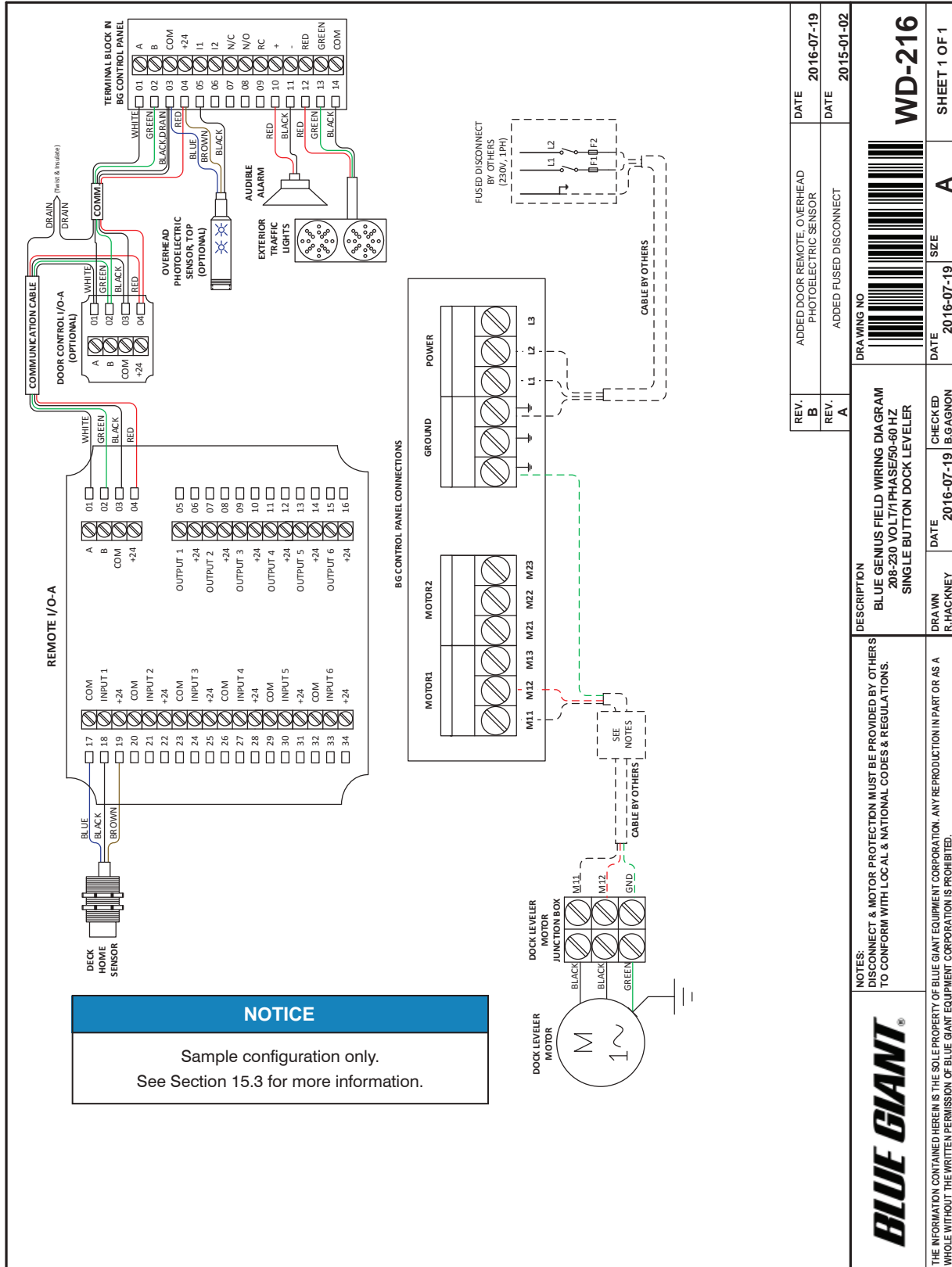

REV. B	ADDED DOOR REMOTE OVERHEAD PHOTOELECTRIC SENSOR	DATE 2016-07-19
REV. A	ADDED FUSED DISCONNECT	DATE 2015-01-02
DESCRIPTION BLUE GENIUS FIELD WIRING DIAGRAM 208-230 VOLT/1PHASE/50-60 HZ SINGLE BUTTON DOCK LEVELER		
DRAWN R. HACKNEY	CHECKED B. GAGNON	DATE 2016-07-19
NOTES: DISCONNECT & MOTOR PROTECTION MUST BE PROVIDED BY OTHERS TO CONFORM WITH LOCAL & NATIONAL CODES & REGULATIONS.		DRAWING NO WD-216
THE INFORMATION CONTAINED HEREIN IS THE SOLE PROPERTY OF BLUE GIANT EQUIPMENT CORPORATION. ANY REPRODUCTION IN PART OR AS A WHOLE WITHOUT THE WRITTEN PERMISSION OF BLUE GIANT EQUIPMENT CORPORATION IS PROHIBITED.		SIZE A SHEET 1 OF 1

15.8 OPTIONAL EXTERIOR TRAFFIC LIGHT / MIRROR IMAGE SIGN

The LED traffic lights and mirror image drive warning sign improve loading dock safety.

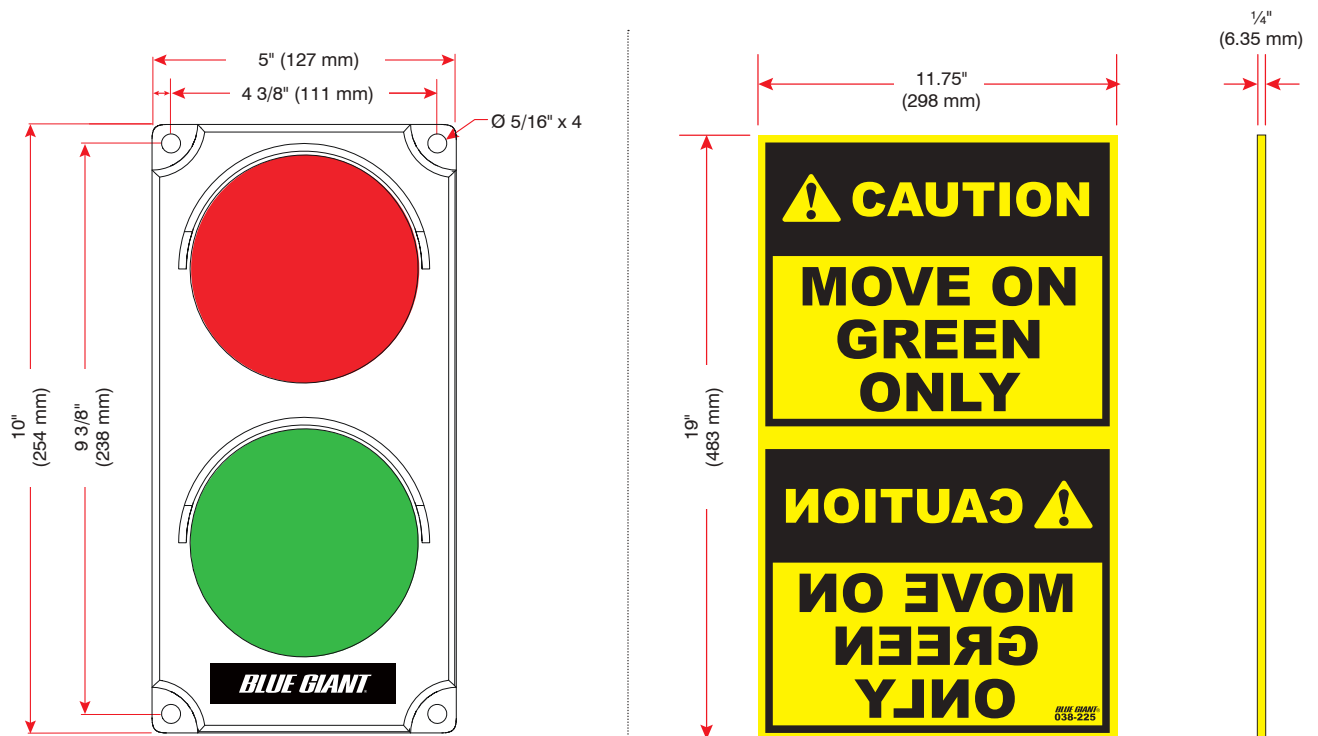

Exterior driver traffic light, part # 032-806.

Exterior driver warning sign, part # 038-225.
(French 038-225F / Spanish 038-225S / Portuguese 038-225P)

NOTE: Mount to a flat surface. DO NOT deform light housing with irregular wall surface.

15.9 OPTIONAL HOME INTERLOCK SENSOR

- Ties sequence of restraint to dock leveler operation
- Loading dock safety is improved with accurate operation sequence
- Interior traffic light and restraint release operation relies on interlock capability
- Mounted at parked position of any leveler

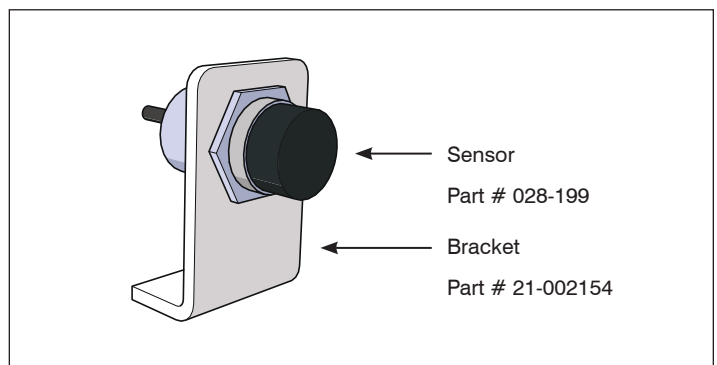

Home interlock sensor (home/lip sensor), part # 26-011290.

BLUE GIANT[®]
BLUE GIANT EQUIPMENT CORPORATION

Corporate 410 Admiral Blvd
Mississauga, ON, Canada L5T 2N6
t 905.457.3900 f 905.457.2313

USA 6350 Burnt Poplar Road
Greensboro, NC 27409
www.bluegiant.com