

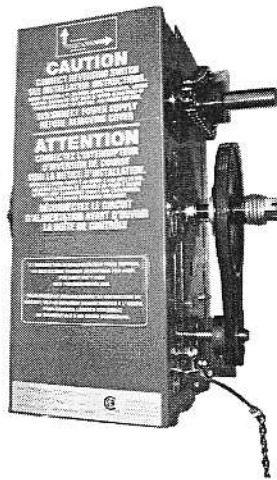

MICANAN SYSTEMS INC.

INSTALLATION AND INSTRUCTION MANUAL

MODELS: *PRO-LHA*



2 YEAR WARRANTY

Model : _____

Serial # _____

Installation Date: _____

Wiring Diagram: _____

Feb. 2009

TABLE OF CONTENTS

	PAGE:
VERIFICATION OF OPERATOR AND HARDWARE _____	3
SPECIFICATIONS _____	4
SAFETY INSTRUCTIONS _____	5
INSTALLATION _____	6
LIMIT SWITCH ADJUSTMENT _____	9
CONNECTION OF POWER SUPPLY AND CONTROL STATION _____	10
CONNECTION OF REVERSING EDGE DEVICE AND CONTROL ACCESSORIES _____	11
CLUTCH ADJUSTMENT _____	12
BRAKE ADJUSTMENT _____	12
EMERGENCY MANUAL OPERATION _____	13
OPERATOR MAINTENANCE _____	14
MECHANICAL DRAWINGS AND PARTS LISTS _____	15
ELECTRICAL DIAGRAMS _____	17
WARRANTY _____	19

WARNING

DO NOT CONNECT TO ELECTRICAL
POWER DURING INSTALLATION
OR SERVICING OF OPERATOR

IMPORTANT

FOR ANY QUESTIONS CONCERNING THE SAFETY OR
OPERATION OF THIS OPERATOR PLEASE CONTACT
MICANAN SYSTEMS AT 1-877-888-1116

VERIFICATION OF OPERATOR AND HARDWARE

Upon delivery of your MICANAN SYSTEMS medium-duty jackshaft for sheet metal door operator, please inspect the unit carefully for damage. Verify that operator horsepower, voltage, phase and amperage correspond to available power supply and door application. Check that along with your operator you have received the following standard hardware.

- 1 x OPEN/CLOSE/STOP 3-button control station:

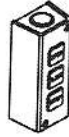

- 1 x #41 Drive chain package : 5' (1.2m) c/w #41 connecting link

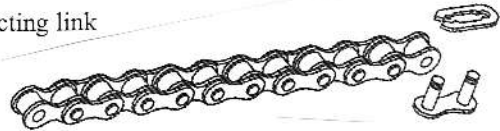

- 1 x Drive Sprocket 41B14 x 1" c/w 2 set screws and 1/4" x 1-1/4" keyway



- 1 x Chain keeper

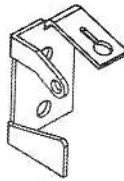

- 1 x Keyring

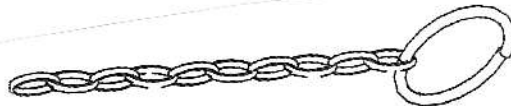

- 4 x 3/8" bolt, hex nut, lock washer and flat washer

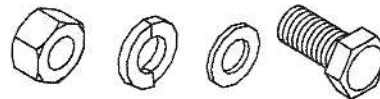

- 1 x pocket wheel hand chain (2 x door height less 4' (1.2m))



- 1 x Set of Warning signs



PRO-LHA SPECIFICATIONS

PRO-LHA medium duty jackshaft operators are designed for commercial sheet metal doors provided that doors are driven by a drive shaft with low duty cycles. Model PRO-LHA operator incorporates a chain hoist for manual operation of the door. Model PRO-LHAB has additional solenoid brake system.

STANDARD OPERATOR WEIGHT: 45-50 LBS

MOTOR: Intermittent duty 1000 RPM motor with high starting torque.

- Thermally protected by a built-in thermostat that cuts power to the motor and control circuit when overheating.
- Horsepower: 1/2HP
- Voltage: 115V, 220V 1-phase

IMPORTANT NOTE

THIS MEDIUM DUTY OPERATOR IS DESIGNED TO OPERATE
A MAXIMUM OF 15 COMPLETE CYCLES PER HOUR.

REDUCTION: Primary: (4L) V-belt and pulleys (3" to 7" diameter), Secondary: #41 chain and sprockets

OUTPUT SHAFT SPEED: 39 RPM

BRAKE : Mechanical Brake system to prevent coasting and maintain door position.

SOLENOID BRAKE (OPTIONAL): Solenoid Brake system available for model PRO-LHAB.

WIRING TYPE (STANDARD): C-2 Wiring constant pressure on close, momentary contact on open and stop. Wired to accept reversing edge, radio control, photocells, loops and OPEN/CLOSE devices.

NOTE: If momentary contact on close (B2) wiring is desired: Re-install the purple wire onto terminal #5.

TRANSFORMER: 24VAC control circuit, supplies power to drive control relays with 15VA power available for external devices.

LIMIT ADJUSTMENT: 4 micro switches that control door travel. These limit switches are activated by fully adjustable screw type cams.

EMERGENCY DISCONNECT: Floor level cable disconnect system with electrical cut-out feature allows person to manually operate the door by chain hoist in case of emergency.

CLUTCH: Adjustable friction clutch to minimize damage to door operator, door or vehicles.

OPERATOR DIMENSIONS:

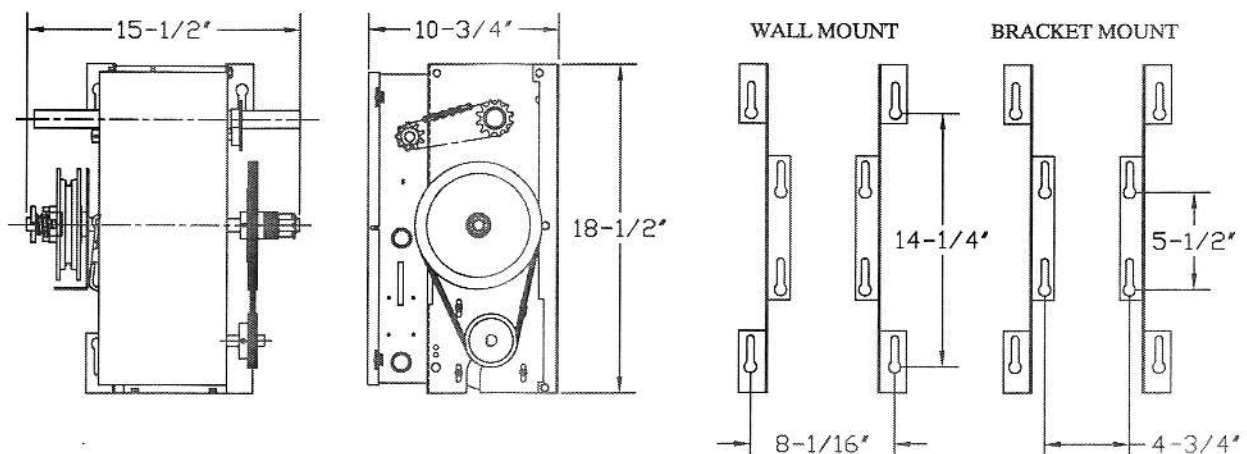

SAFETY INSTRUCTIONS**WARNING**

TO REDUCE THE RISK OF INJURY OR DEATH:
READ AND FOLLOW ALL INSTRUCTIONS

- Do not allow children to play with door.
- Before installation, be sure that operator is suited for type of door and application
- Connect a reversing device to prevent entrapment if door is located near pedestrian traffic.
- Place control device within clear sight of the door but at a minimum distance from the door so that user cannot reach moving door parts when operating.

- Outdoor external devices should have security features to prevent unauthorized operation of the door.
- Never cross under a moving door.
- Press the "OPEN" device or use emergency disconnect mechanism if a person is trapped under the door.

- Do not use disconnect mechanism or manually operate door unless power has been electrically disconnected.

- Keep doors properly maintained. Test door and service regularly. Have a qualified service person make repairs. *An unmaintained door system could cause injury or death.*

- The owner or users must understand the safety and operation of door system. Insure that this installation manual be located close to the door system.

INSTALLATION INSTRUCTIONS

WARNING

DO NOT INSTALL THIS OPERATOR
BEFORE READING THIS MANUAL CAREFULLY.

- Note:
- Installation of operator must be done by a qualified installer. Door must be properly installed and working smoothly. Remove all door locks prior to installation.
 - The PRO-LHA operators have dual output shafts and may be mounted on left (standard) or right hand side of door. If handing of operator must be reversed, loosen set screws, remove drive sprocket and keyway and install on opposite side of drive shaft.

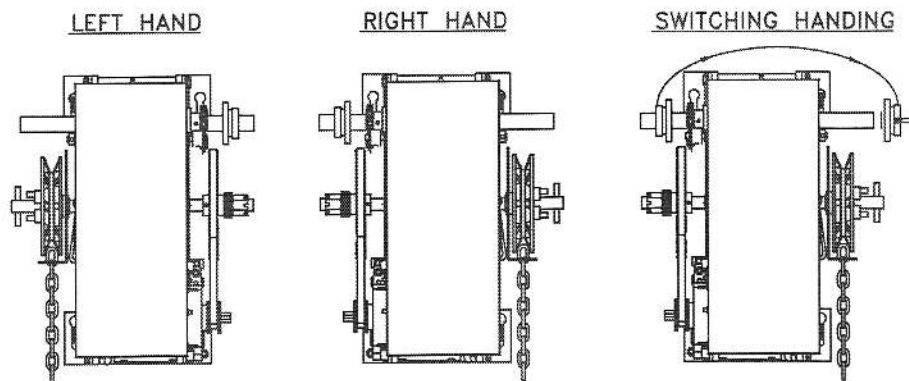

- For the PRO-LHA operator which incorporates a chain hoist mechanism the handing of the operator must be stated at time of order. Depending on installation, if handing of chain hoist is not correct the hand chain may hang in door opening. If this is the case, swing chain off to the side and hook it over the top of the door jamb. Do not attempt to reverse chain hoist on site.

1. Install control station away from all moving door parts, within sight of the door and a minimum of 5 ft (1.5 m) from the ground.
2. Install entrapment warning sign next to control station.

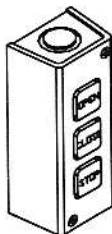

3. As a general rule, the door operator should be installed below the drive shaft and as close to the door as possible. The ideal distance between the operator drive shaft and the door shaft is approximately 12" (30cm) to 15" (38cm). The operator may be wall/bench mounted or bracket/shelf mounted. These two mounting configurations are shown below:

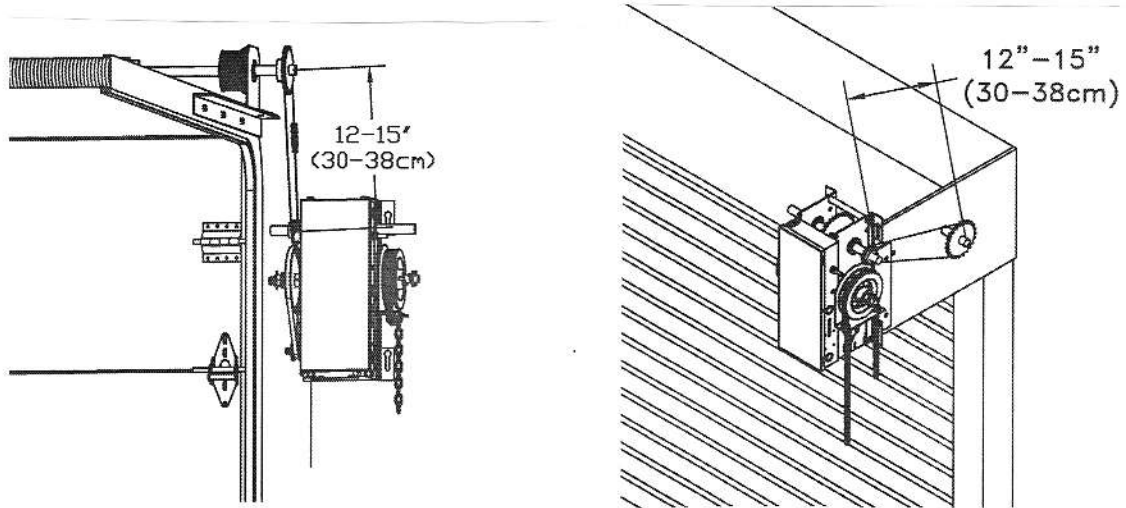

4. Mount the operator to the wall, hood or bench with 3/8" bolts, nuts and washers provided or with lag bolts and shields if installation requires it. Make sure that operator is secured but do not tighten bolts.
5. Place door sprocket on door shaft and align with operator drive sprocket but do not insert keyway or set screws.
6. If an optional chain spreader has been ordered with your operator, install as shown below:

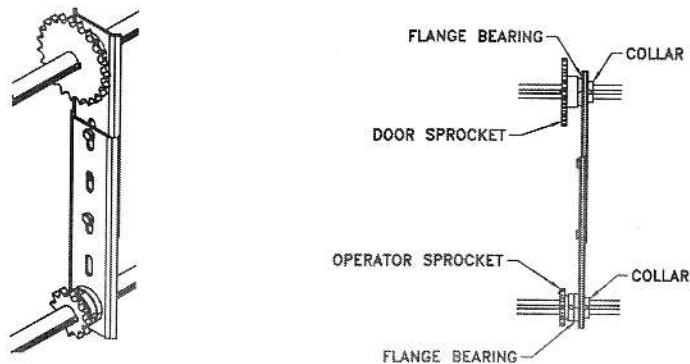

7. Install drive chain over sprockets, cut to a suitable length and connect with connecting link.
8. Lower or raise operator to adjust chain tension so that there is no more than 1/4" chain slack between sprockets. Tighten operator mounting bolts.
9. Carefully re-align sprockets, if necessary and secure keyway and set screws.
10. Install hand chain by wrapping it through chain guard holes and pocket wheel. Allow chain to hang down towards floor. Cut chain and connect so that chain is 2' to 3' from the floor.

11. Install chain keeper to wall near hand chain at approximately 4' from floor. Run disconnect chain through keyhole of chain keeper and cut excess chain links if required. Attach keyring to end of disconnect chain.

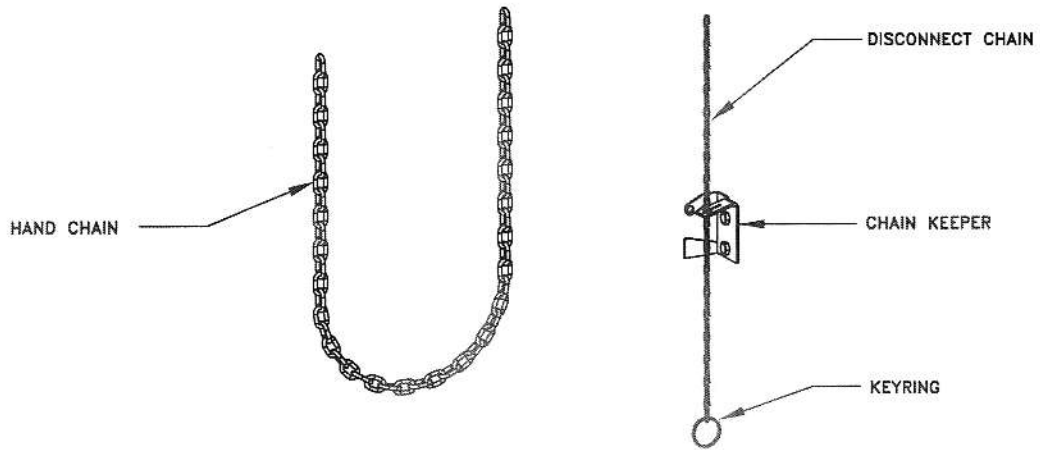

12. If an *optional* floor level disconnect lever was ordered in lieu of the chain keeper, mount to wall with suitable hardware. Attach both chains together using keyring provided. Allow disconnect chain to be slightly slack when lever is in the up position.

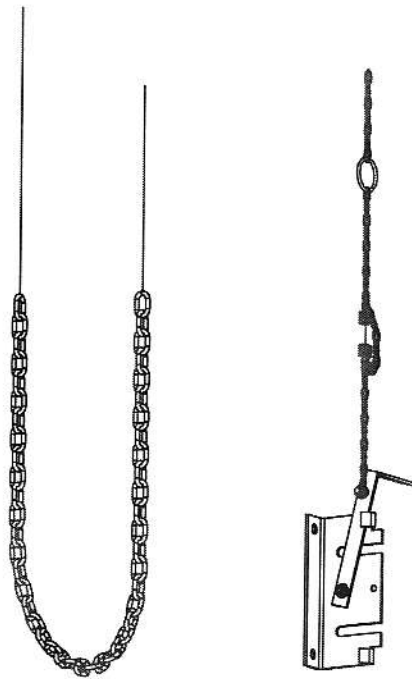

LIMIT SWITCH ADJUSTMENT

Adjustment of door travel is done by moving the limit cams on the threaded shaft. The position of the 4 limit switches are factory adjusted and should not be altered. The limit switches are:

- “Open” limit switch: End of door travel in the fully open position
- “Closed” limit switch: End of door travel in the fully closed position
- “Advanced Open” limit switch: Used for open/close devices or timer to close features
- “Advanced Closed” Limit switch: Used to prevent reversing device from reversing door when door is almost fully closed.

WARNING

TO REDUCE THE RISK OF INJURY OR DEATH:

DO NOT ATTEMPT TO MAKE LIMIT SWITCH ADJUSTMENTS
UNLESS POWER HAS BEEN ELECTRICALLY DISCONNECTED

To adjust door travel:

1. **Open cycle:** Depress cam plate and spin “Open” limit cam away from “Open” limit switch to increase door travel or spin “Open” limit cam towards the “Open” limit switch to decrease door travel. After each adjustment ensure that cam plate fully engages in slots of both limit nuts.
2. Adjust “Open” limit cam so that door stops at the desired fully open position.
3. **Close cycle:** Depress cam plate and spin “Close” limit cam away from “Close” limit switch to increase door travel or spin “Close” limit cam towards the “Close” limit switch to decrease door travel. After each adjustment ensure that cam plate fully engages in slots of both limit nuts.
4. Adjust “Close” limit cam so that door stops at the desired fully closed position.

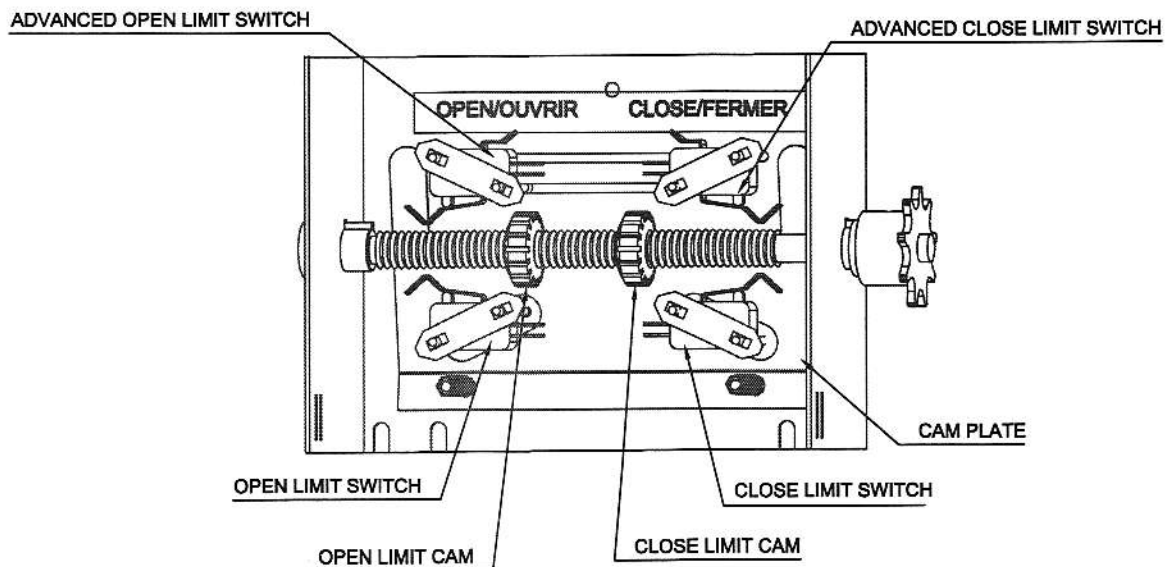

CONNECTION OF POWER SUPPLY AND CONTROL STATION

WARNING

COMPARE AVAILABLE POWER SUPPLY VOLTAGE TO OPERATOR NAMEPLATE PRIOR TO ELECTRICAL CONNECTION. FAILURE TO CONNECT APPROPRIATE POWER SUPPLY VOLTAGE MAY CAUSE SERIOUS DAMAGE TO OPERATOR.

Refer to electrical diagrams inside control box cover or at the end of this manual prior to connection of power supply or control station.

WARNING

TO REDUCE THE RISK OF INJURY OR DEATH:

ALL ELECTRICAL CONNECTIONS SHOULD BE MADE BY A QUALIFIED SERVICE PERSON

DO NOT ATTEMPT TO MAKE ELECTRICAL CONNECTIONS TO OPERATOR UNLESS
POWER SUPPLY HAS BEEN DISCONNECTED AT FUSE BOX

OPERATOR MUST BE CONNECTED IN ACCORDANCE TO LOCAL ELECTRICAL CODES
AND GROUNDED TO GREEN GROUND LUG LOCATED INSIDE CONTROL BOX

POWER WIRING: Use 1-1/8" (2.85 cm) diameter holes for all power wiring.

Connect single phase power supply 120 VAC to terminals L (line) and N (neutral) on three-pole power terminal strip.

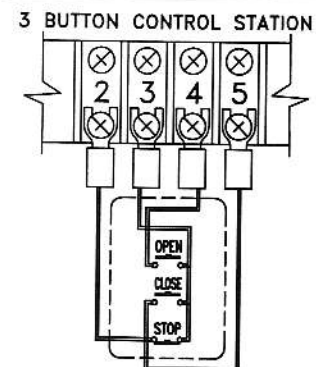
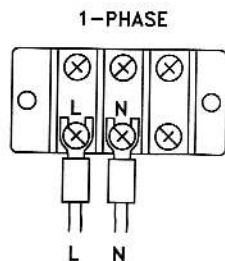

CONTROL WIRING: Use 7/8" (2.22 cm) diameter holes for all control wiring.

Note: Do not run control wires and power wires in same conduit.

- Install control station within clear sight of door but away from all moving parts of door or hardware. Install Entrapment warning sign next to control station. Connect 3-button (open/close/stop) push button station to terminals 2, 3, 4 and 5. Refer to electrical diagram for connection of two 3-button stations.

NOTE: After electrical connections are made, manually move door to mid-position and, using the control station press the "Open" button for several seconds and then press the "Stop" button. If door did not move in correct direction verify wiring of control station.

CONNECTION OF A REVERSING EDGE DEVICE AND CONTROL ACCESSORIES

1. **Reversing Edge device** (must be normally open contact):

Note: If the door is controlled by any device or wired in such a manner that the door is not controlled by constant pressure on close then an appropriate reversing edge must be installed.

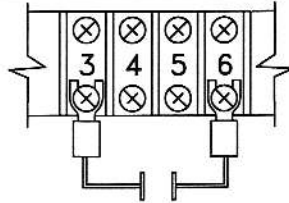

2. **External interlock:** Remove jumper between terminals 1 and 2 and wire interlock between these two terminals.

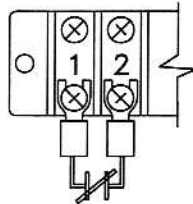

3. **Radio control receiver:** Wire standard radio receiver to separate radio strip on side of control box or to terminals 7, 8 and 9 on control terminal strip inside control box.

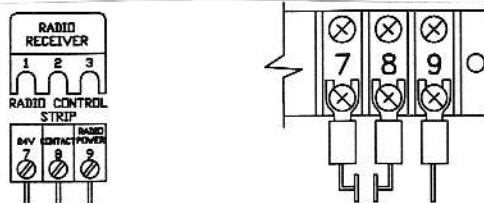

4. **Single button open/close device:** Wire to terminals 7 and 8 on control terminal strip.

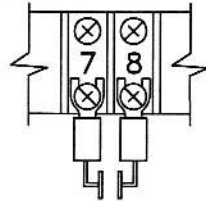

5. **Loop detectors, photocells and other reversing devices:** Wire to terminals 3 and 6 on control terminal strip.

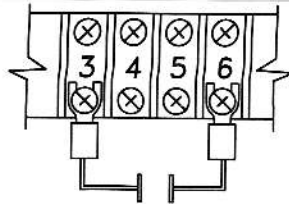

6. **24 Volt power:** Wire to terminals 1 and 9 on control terminal strip

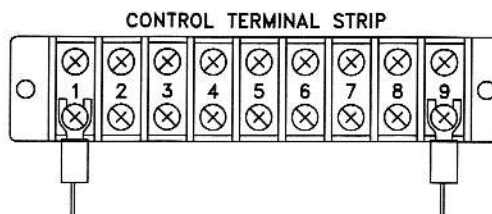

CLUTCH ADJUSTMENT

1. Remove cotter pin tapped to pulley.
2. Rotate clutch nut counterclockwise (loosen) until there is insufficient tension to permit clutch to drive door.
3. Gradually tighten clutch nut until the tension on belleville washers is sufficient to permit clutch to drive door smoothly but will allow clutch to slip if door is obstructed. It should be possible to stop moving door by hand if clutch is properly adjusted.
4. Lock clutch nut in place by inserting cotter pin.

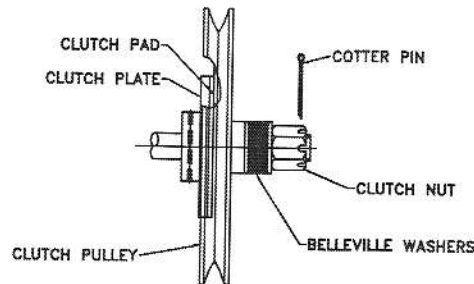

BRAKE ADJUSTMENT (For PRO-LHAB only)

- The brake adjustment is factory set and should only require minor adjustment after extensive use.
- Verify brake adjustment by manually holding in solenoid plunger. When brake is properly adjusted, the brake shoe pads should make complete contact with brake drum with sufficient brake spring tension to stop and maintain door when solenoid is de-energized. When solenoid is energized, brake shoes should release from drum with sufficient clearance to avoid contact between shoes and drum.
- To adjust brake tension, tighten (to increase) or loosen (to decrease) nylon lock nut on brake spring bolt. Observe solenoid during electrical testing of brake. Brake spring tension must be adjusted so that solenoid should pull and release smoothly and quietly. Too much or too little tension on brake spring may cause solenoid to burn out.
- To adjust individual brake shoes, loosen nut on brake shoe adjustment bolt and adjust bolt. When properly adjusted, there should be a small clearance between adjustment bolt and solenoid bracket when solenoid is de-energized. When solenoid is energized, brake shoes should move away from drum with sufficient clearance to avoid friction between brake shoe pad and drum. After adjustments are made be sure to tighten nuts on brake shoe adjustment bolts.

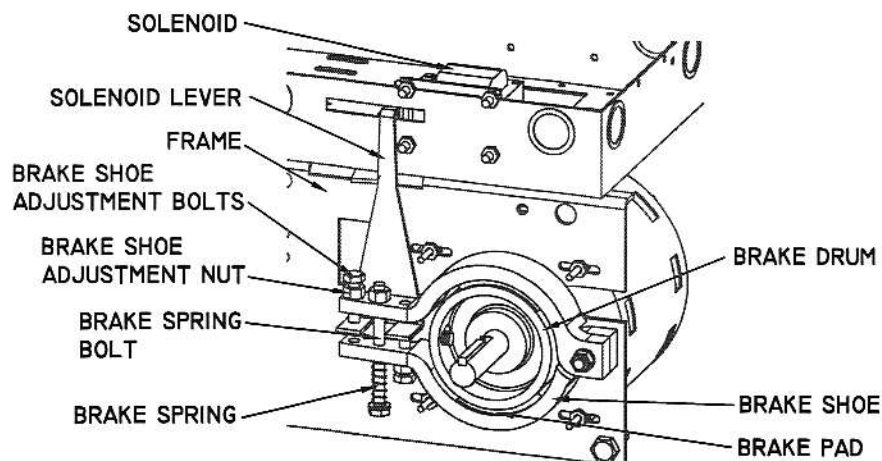

EMERGENCY MANUAL OPERATION

- The PRO-LHA operators are equipped with an emergency disconnect device with interlocked power cut-out switch to manually operate door in case of emergency. This feature should not be used to manually operate a malfunctioning door.

WARNING

TO REDUCE THE RISK OF INJURY OR DEATH:

DO NOT ATTEMPT TO USE EMERGENCY DISCONNECT SYSTEM WHILE OPERATOR IS RUNNING.

POWER TO THE OPERATOR SHOULD BE TURNED OFF PRIOR TO OPERATING DOOR MANUALLY.

1. **If operator is supplied with standard chain keeper:** Pull the disconnect chain through the hole of keyhole and lock in place by inserting chain in slot of keyhole.

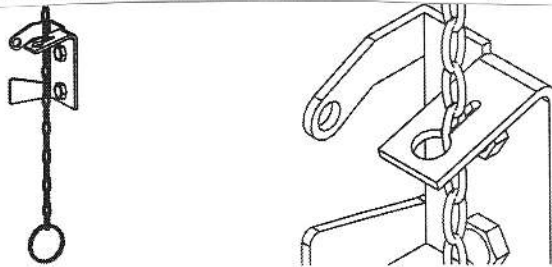

2. **If operator is supplied with optional floor level disconnect lever:** Pull disconnect lever downwards and lock in place by bending lever around bracket lip as shown.

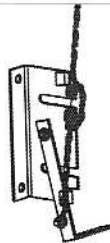

3. Operate door by pulling on hand chain. To return to electrical operation release disconnect chain and allow to return to original position. Lock hand chain in place (to Chain Keeper or Floor Level Disconnect) when not in use.

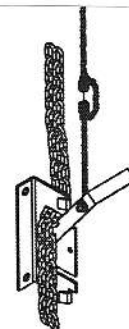
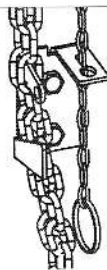

OPERATOR MAINTENANCE

WARNING

TO REDUCE THE RISK OF INJURY OR DEATH:
DO NOT ATTEMPT TO SERVICE THE OPERATOR UNLESS
POWER SUPPLY HAS BEEN DISCONNECTED

- Inspect manual function of the door every 3-months. Make sure that door runs smoothly. If door does not manually open or close freely, have a qualified service person make repairs. Do not attempt to electrically operate a malfunctioning door.
- Every 3 months:
 1. Verify that door area is kept clean. Remove any obstructions that would prevent proper door operation.
 2. Check for any excessive slack in chains. If chain adjustment is required verify and adjust limit switches, if necessary.
 3. Verify and adjust clutch.
 4. Lubricate chains, bearings and limit shaft.
 5. Verify that motor and operator runs smoothly and quietly.
- Every 6 months:
 1. Verify tightness of all fasteners and set screws.
 2. Verify that operator is properly secured.
 3. Inspect manual disconnect.
 4. Verify tension and condition of V-belt
- Every 12 months:
 1. Perform a complete service check.
 2. Verify that inside of control box is clean and that grounding wires, terminations and power terminations do not show signs of corrosion.
 3. Verify tightness of all terminal strip screws and electrical connections.
 4. Verify power supply, voltage of input terminals during operation.
 5. Verify that current consumption of operator corresponds to nameplate information

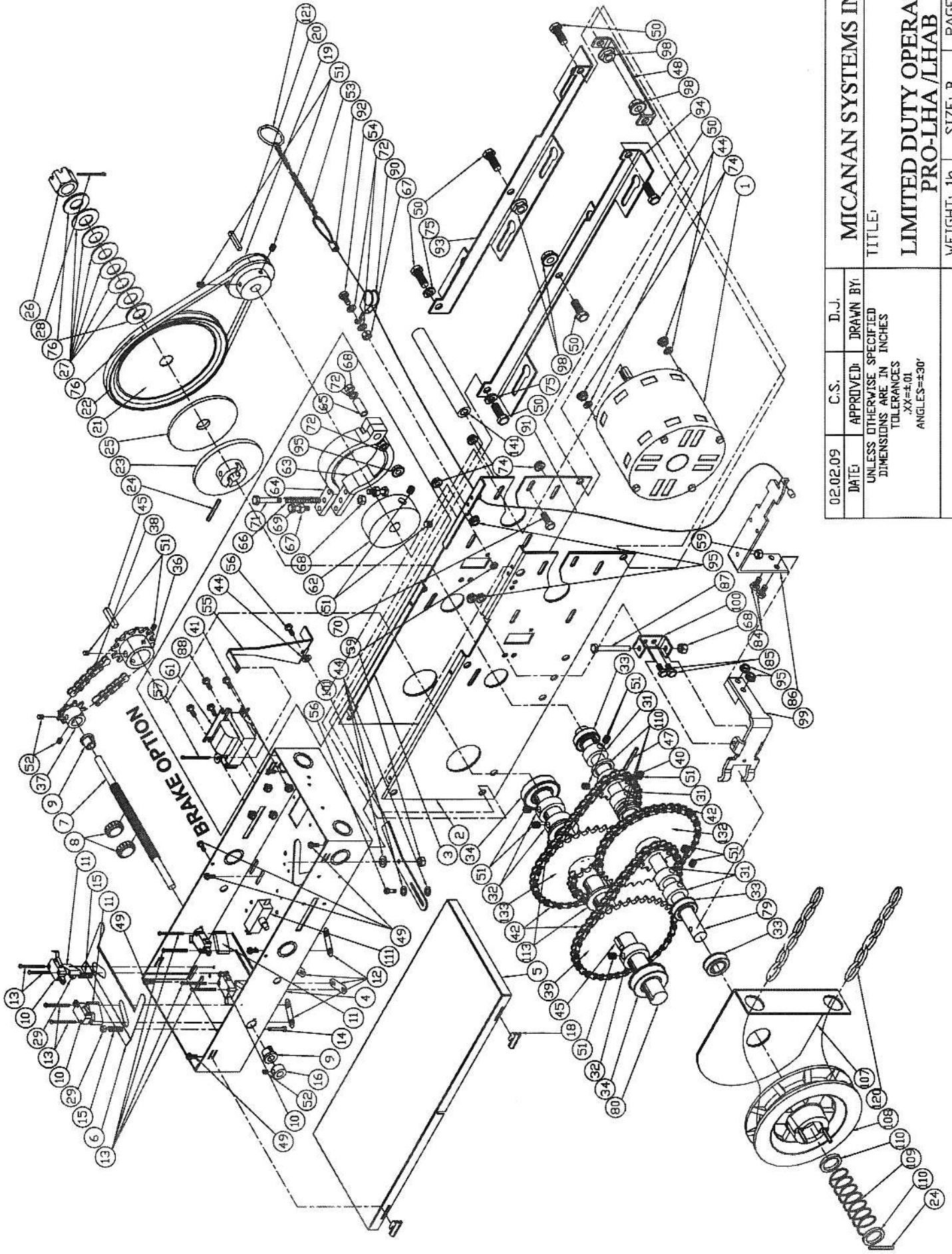

02.02.09	C.S.	D.J.
DATE	APPROVED:	DRAWN BY:
UNLESS OTHERWISE SPECIFIED DIMENSIONS ARE IN INCHES TOLERANCES .XX±.01 ANGLES±.30°		
REVISION:A		

MICANAN SYSTEMS INC.
 TITLE:
**LIMITED DUTY OPERATOR
 PRO-LHA /LHAB**
 WEIGHT: 16 SIZE: B PAGE: 1/1
 CAD FILE: 3D-PROLHA/LHAB ASTA-XE SCALE:

Replacement parts list PRO-LHA/LHAB

CODE	PART #	DESCRIPTION (PRO-LHA)	PRO-LHA	PRO-LHAB
			QTY	C/W BRAKE QTY
MB01010	1	MOTOR (limited duty)	1	1
MM00208	2	ASTA LIMITED DUTY FRAME (LEFT) MS10209	1	1
MM00209	3	ASTA LIMITED DUTY FRAME (RIGHT) MS10210	1	1
MM00076	4	CONTROL BOX (Limited Duty) MS10092	1	1
MM00077	5	CONTROL BOX COVER (Limited duty) MS10093	1	1
MM00024	6	CAM PLATE MS10013	1	1
ME00035	7	LIMIT SHAFT 3/8-1/2 x 8.436"	2	2
MG00030	8	LIMIT CAM 1/2-20 UNF	2	2
MH00001	9	BRONZE T-BUSHING 3/8" ID	4	4
MK00004	10	LIMIT SWITCH	4	4
MJ00006	11	LIMIT SWITCH SPACER 3/4" LONG	4	4
MG00003	12	DOUBLE NUT FOR LIM-SW.	4	4
MF00003	13	R.H. PHILLIPS MACHINE SCREW 4-40 UNCx1-1/2"	8	8
MF00004	14	R.H. PHILLIPS MACHINE SCREW 6-32 UNC x1"	2	2
MC00001	15	CAM PLATE COMPRESSION SPRING (.178IDx 0.32GX.55L)	2	2
MH00006	16	COLLAR 3/8" ID	1	1
MM00046	18	CONTROL BOX HINGE	2	2
MI00026	19	MOTOR PULLEY MA30 4L, 5/8 ID X 3" OD	1	1
ME00018	20	KEYWAY 3/16 SQ. x 1-1/4" LONG	1	1
MI00017	21	PULLEY 7" OD c/w bushing 3/4" ID	1	1
MI00035	22	V-BELT A-27	1	1
MJ00004	23	CLUTCH PLATE ALUMINUM 3/4" ID	1	1
MQ00007	24	SPRING PIN 1/4" x 2" LONG	2	2
MJ00005	25	CLUTCH PAD 3/4" ID	1	1
MG00014	26	SLOTTED HEX NUT 3/4-24UNF	1	1
MG00004	27	BELLVILLE WASHER 13/16 IDx1-3/16X1/8	6	6
MQ00002	28	COTTER PIN 1/8 x 2.5" LONG	1	1
MG00007	29	HEX NYLON LOCK NUT 6-32UNC	2	2
MH00008	31	COLLAR 3/4" ID	4	4
MH00007	32	COLLAR 1" ID	3	3
MH00013	33	FLANGE BEARING 3/4" IDx1-3/8 OD	3	3
MH00009	34	FLANGE BEARING 1" IDx2"OD	2	2
MD00025	36	SPROCKET 410B23 X 1"	1	1
MD00111	37	SPROCKET 410B9 X 3/8"	1	1
MR00030	38	#410 ROLLER CHAIN 35 PITCH C/W CONNECTING LINK	1	1
MD00280	39	SPROCKET 41B32 x 1" C/W 1.69" HUB, 7/8" LTB	1	1
MD00242	40	SPROCKET 41B14 x 3/4"	1	1
MG00036	41	RIBBED HEX NUT 8-32UNF	4	4
MD00243	42	#41 ROLLER CHAIN 47 PITCH DRIVE C/W LINK	3	3
MG00016	44	FLAT WASHER #10	4	8
ME00017	45	KEYWAY 1/4" SQ. X 1-1/4" LONG	2	2
MQ00020	47	SPRING PIN 3/16" x 1-3/4" LONG	1	1
MM00128	48	LIMITED DUTY FRAME SUPPORT U-BRACKET MS10141	1	1
MF00046	49	H.H. SLOTTED SELF ROUNDING WASHER HEAD SCREW 10-32 UNF x 1/2"	7	7
MF00011	50	H.H. BOLT 3/8"-16UNC X 3/4" LONG	6	6
MQ00008	51	SET SCREW 5/16" -18	15	17
MQ00009	52	SET SCREW 1/4" - 20	3	3
MR00008	53	DISCONNECT SASH CHAIN	1	1
MF00008	54	HEX HEAD BOLT 1/4" - 20 X 1" LONG	1	1
MM00078	55	SOLENOID LEVER LIMITED DUTY MS10094	1	1
MF00005	56	R.H. PHILLIPS MACHINE SCREW 10-32 UNF x 5/8"	1	3
MQ00001	57	COTTER PIN 1/8 x 1.5"	1	1
MG00008	59	HEX NYLON NUT 10-32 UNF	1	3
MK00026	61	SOLENOID 120V	1	1
MJ00003	62	BRAKE DRUM	1	1
MJ00001	63	BRAKE SHOE LEFT	1	1
MJ00002	64	BRAKE SHOE RIGHT	1	1
MH00002	65	MILD STEEL BUSHING 9/32ID x 13/32OD x1-1/16	1	1
MQ00002	66	BRAKE COMPRESSION SPRING (5/16"ID-.05G-2.50L)	1	1
MG00006	67	HEX NUT 1/4-20UNC	1	3
MG00009	68	HEX NYLON LOCK NUT 1/4-20UNC	1	3
MF00028	69	HEX HEAD BOLT 1/4-20UNC x 1-1/4" (Full thread)	1	2
MF00076	70	HEX HEAD BOLT 1/4-20UNC x 2" (full thread)	1	1
MF00044	71	HEX HEAD BOLT 1/4-20UNC x 4" (partial thread)	1	1
MG00017	72	1/4" FLAT WASHER	2	4
MG00010	74	RIBBED HEX NUT 10-32UNF	8	8
MG00018	75	LOCK WASHER 3/8"	2	2
MG00019	76	FLAT WASHER 13/16" I.D.x1.50D (3/4" SHAFT SIZE)	2	2
ME00037	79	INPUT SHAFT PRO-LH 3/4" x 15.54"	1	1
ME00007	80	DRIVE SHAFT JACKSHAFT 1" X 15"	1	1
MF00007	84	HEX HEAD BOLT 1/4" - 20UNC x 3/4"	2	2
MF00006	85	HEX HEAD BOLT 1/4" - 20UNC x 1/2"	2	2
MM00211	86	ASTA LIMITED DUTY DISCONNECT LEVER MS10212	1	1
MF00009	87	HEX HEAD BOLT 1/4" - 20UNC x 2-1/4" (partial thread)	1	1
MF00045	88	H.H. SLOTTED SELF ROUNDING WASHER HEAD SCREW 8-32UNF x 3/8"	1	4
MU00001	90	SWIVEL PULLEY	1	1
MR00001	91	DISCONNECT CABLE 3/32 X 12" LONG	1	1
MQ00011	92	3/32" ALUMINUM OVAL SLEEVE	1	1
MM00130	93	FRAME FOOT LIMITED DUTY (LEFT) MS10140	1	1
MM00129	94	FRAME FOOT LIMITED DUTY (RIGHT) MS10139	1	1
MG00011	95	RIBBED HEX NUT 1/4" - 20 UNC	5	6
MG00013	98	RIBBED HEX NUT 3/8" - 16UNC	4	4
MM00210	99	ASTA LIMITED DUTY DISCONNECT ARM (MS10211)	1	1
MM00022	100	SUPPORT U-BRACKET PRO-LH/LH MS10015	1	1
MM00080	101	PIVOT BRACKET LIMITED DUTY MS10096	1	1
MM00013	107	CHAIN GUARD MS10014	1	1
MI00003	108	POCKET WHEEL C/W 3/4" BUSHING & 2 1/4" SPRING PINS	1	1
MC00003	109	COMPRESSION SPRING (0.80ID x 0.092G x 1.80L LONG)	1	1
MG00021	110	FLAT WASHER 7/8" ID x 1-1/8" OD	5	5
MK00005	111	CUTOUT SWITCH C/W NUT & WASHER	1	1
MG00020	113	FLAT WASHER 1-1/16" ID x 1-3/4" OD x 1/8" THICK	2	2
MR00006	120	HAND CHAIN	1	1
MU00002	121	KEYRING 1-1/4"	1	1
MD00247	132	DOUBLE SPROCKET 41B14/41A32 C/W 3/4" BUSHING	1	1
MD00246	133	DOUBLE SPROCKET 41B14/41A32 C/W 1" BUSHING	1	1
ME00050	141	FRAME SUPPORT SHAFT 3/4" X 6" LONG	1	1

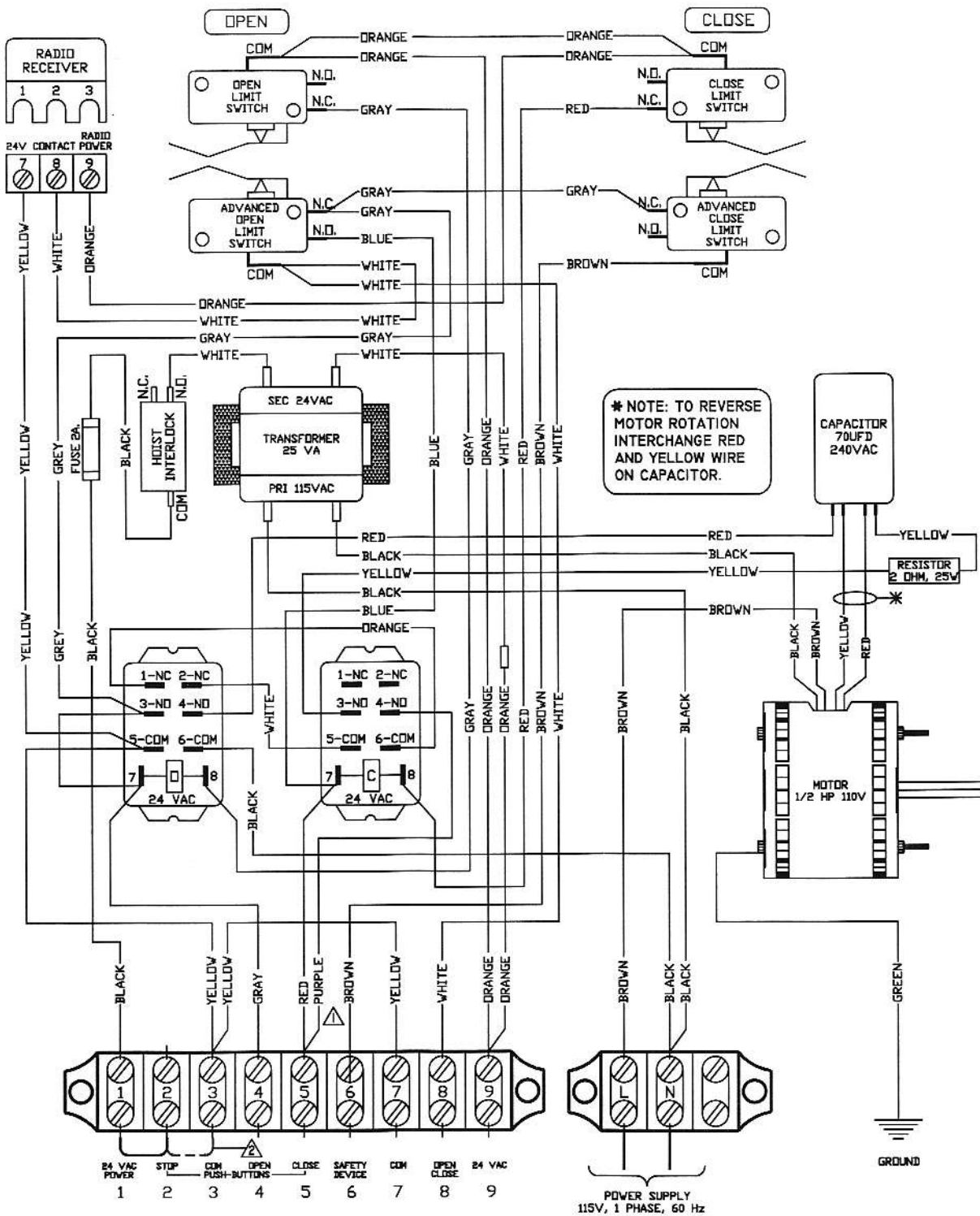

* NOTE: TO REVERSE MOTOR ROTATION INTERCHANGE RED AND YELLOW WIRE ON CAPACITOR.

WARNING
 MICANAN STRONGLY RECOMMENDS THE USE OF ENTRAPMENT PROTECTION SYSTEMS WHEN B2 (MOMENTARY CONTACT) WIRING IS USED.

CONTROL WIRING OPTION ON CLOSE:
 THIS OPERATOR LEAVES THE FACTORY WITH A "C2" WIRING - MEANING THAT CONSTANT PRESSURE IS REQUIRED TO CLOSE THE DOOR. IF MOMENTARY OPERATION ON CLOSE - "B2" WIRING - IS DESIRED, THEN RE-INSTALL THE PURPLE WIRE ON TO TERMINAL #5.

IF STOP BUTTON NOT USED, ADD JUMPER BETWEEN 2 & 3.
 NOTE: MINIMUM 18 AWG WIRE MUST BE USED FOR FIELD CONNECTIONS.

I-PHASE PRO-LHA, 1/2HP, 110V
MSLHA-WW
 REV. E | DATE: 29.01.07
 TECH. HELP LINE:
 CANADA: 1-(877) 888-1116
 USA: 1-(888) 816-8584

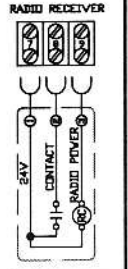
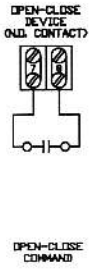
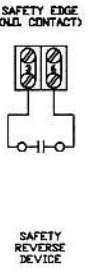
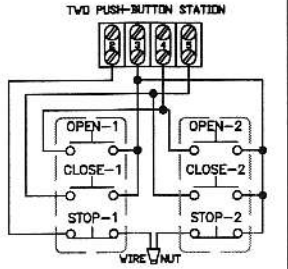
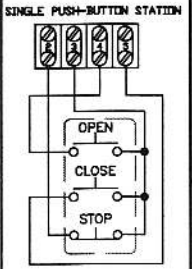
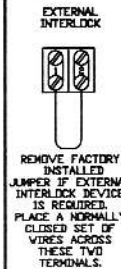

WARRANTY

MICANAN SYSTEMS warrants that materials and workmanship are free from defects for a period of two years from the date of invoice. Materials returned to Micanan deemed defective after examination will be returned at the option of Micanan with repaired, new or re-manufactured parts.

MICANAN SYSTEMS will not be responsible for any extra charges incurred in the process of returning defective material. All returned material must be received pre-paid or it will not be accepted.

This warranty is limited, and in lieu of all other warranty expressed or implied. There is no expressed liability due on the part of the seller.



MICANAN SYSTEMS INC.

HEAD OFFICE

1380 St-Regis
Dorval, Quebec
Canada, H9P 2T5

TEL: (514) 822-1116
1-877-888-1116
FAX: (514) 822-1118

PHOENIX

1236 W. Southern Ave.
Suite 104
Tempe, Az
USA 85282

TEL: (480) 557-0070
1-888-816-8584
FAX: (480) 557-8488

ATLANTA

2885 N. Berkeley Lake Rd.
Suite 7
Duluth, Ga
USA 30096

TEL: (678) 584-2543
1-800-798-2543
FAX: (678) 584-2544

CHICAGO

706 Remington Rd.
Suite D
Schaumburg, Il
USA 60173

TEL.: (847) 839-8303
1-800-670-8303
FAX: (847) 839-8308