

BBU

BATTERY BACKUP UNIT

Installation Instructions

For Use with Model LDC0800
Garage Door Operators

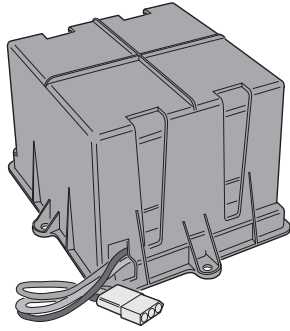

Linear
Building On Innovation.

USA & Canada (800) 421-1587 & (800) 392-0123
(760) 438-7000 - Toll Free FAX (800) 468-1340
www.linearcorp.com

PRODUCT DESCRIPTION

The Model BBU Battery Backup Unit is designed to provide DC power for Linear's Model LDC0800 Garage Door Operator during AC power outages.

The BBU contains two rechargeable batteries that are maintained and charged by the LDC0800 operator. If the installation's AC line power is interrupted, the BBU will power the operator for up to 24 hours. The duration of the operator's battery backup will depend on the number of times the garage door is cycled without AC power. The batteries will be fully recharged within 48 hours after AC power is restored.

The BBU contains an internal sounder to indicate the current status of the battery unit. The unit regularly performs a self-check routine while AC power is present. If the batteries test low or dead, the unit will sound three beeps every minute to indicate that service is required.

Every LDC0800 is compatible with the BBU. The operator now has three pre-drilled holes in the chassis to mount the BBU and a connector for the BBU on the controller board.

For retrofit installations, replace the LDC0800 operator's controller board with a newer Model HAE00061 controller board that has the BBU connector. Refer to the mounting template supplied to drill three holes in the chassis of the operator to mount the BBU.

FEATURES

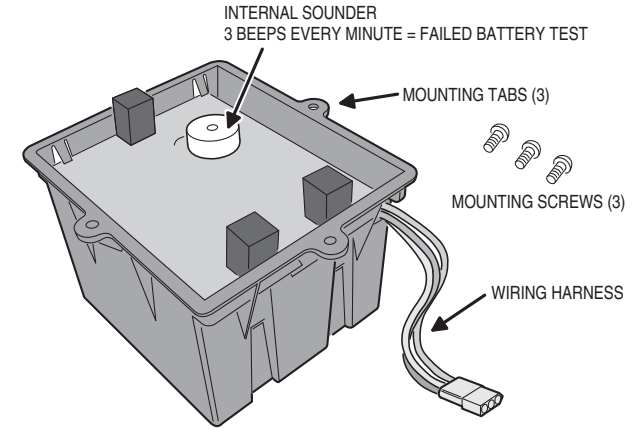

REMOVE OPERATOR COVER

1 UNPLUG THE OPERATOR BEFORE PROCEEDING !!!

2 LOOSEN THE FOUR COVER SCREWS

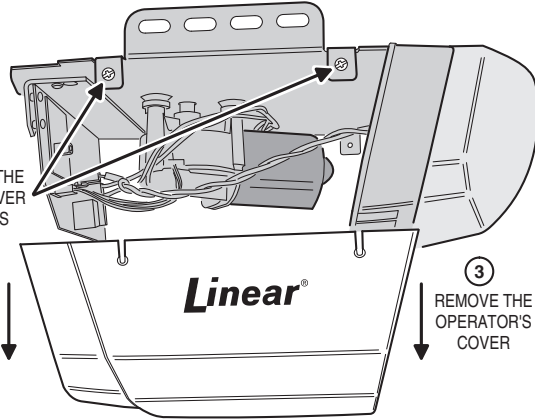

3 REMOVE THE OPERATOR'S COVER

INSTALL BATTERY BACKUP UNIT IN OPERATOR

USE THE THREE SCREWS TO ATTACH THE BATTERY BACKUP UNIT TO THE OPERATOR BASE PLATE

FOR RETROFIT INSTALLATIONS, REFER TO MOUNTING TEMPLATE

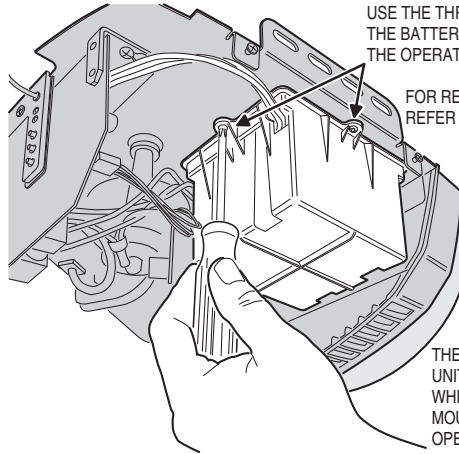

THE BATTERY BACKUP UNIT CAN BE INSTALLED WHILE THE OPERATOR IS MOUNTED OR WHILE THE OPERATOR IS ON THE FLOOR

CONNECT POWER WIRES

REMOVE JUMPER PLUG FROM CONTROLLER BOARD'S 3-WIRE HARNESS (SAVE THE JUMPER PLUG)

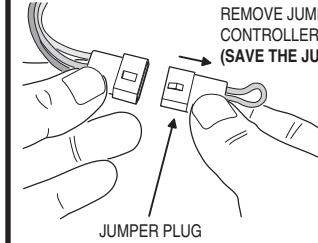

JUMPER PLUG

CONNECT THE 3-WIRE HARNESS TO THE BATTERY BACKUP 3-WIRE HARNESS

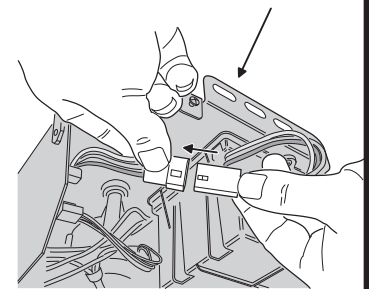

NOTE: THE JUMPER PLUG MUST REMAIN IN PLACE UNTIL THE BATTERY BACKUP UNIT IS INSTALLED

REPLACE OPERATOR COVER

1 REPLACE THE OPERATOR'S COVER

2 TIGHTEN THE FOUR COVER SCREWS

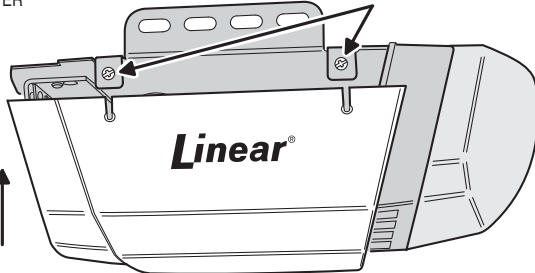

TEST OPERATOR

1 BE SURE TO LET THE BATTERY BACKUP UNIT CHARGE FOR 48 HOURS BEFORE TESTING

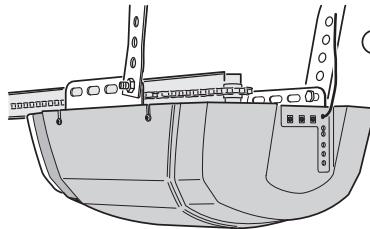

2 UNPLUG THE OPERATOR

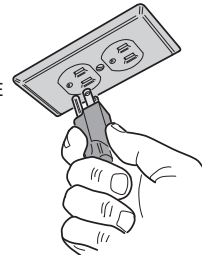

3 TEST RUN THE OPERATOR (THE OPERATOR'S LAMP WILL NOT LIGHT)

4 PLUG THE OPERATOR BACK IN

LINEAR LIMITED WARRANTY

This Linear product is warranted to the original consumer against defects in material and workmanship for 1 year. Linear will repair, or at its option, replace, any device that it finds requires service under this warranty, and will return the repaired or replaced device to the consumer at Linear's cost. Devices must be sent to Linear for service at owner's expense. This warranty does not apply to the product from negligence, abuse, abnormal usage, misuse, accidents, normal wear or tear or due to failure to follow Seller's instructions, or arising from improper installation, storage or maintenance. In no event will Linear be responsible for incidental, compensatory, punitive, consequential, indirect, special or other damages. The remedies provided by this warranty are exclusive. Some states do not allow the exclusion or limitation of incidental and consequential damages, so the above limitation or exclusion may not apply to you. Any warranties implied by law are limited to the time periods set forth above. Some states do not allow limitations on how long an implied warranty lasts, so the above limitation may not apply to you. This warranty gives you specific legal rights, and you may also have other rights which vary from state to state.

For warranty service and shipping instructions contact Linear at the phone number shown below. In order to be protected by this warranty, save your proof of purchase and send a copy with equipment should repair be required. All products returned for warranty service require a Return Product Authorization Number (RPA#). Contact Linear Technical Services at 1-800-421-1587 for an RPA# and other important details.

This equipment generates and uses radio frequency energy and if not installed and used properly, that is, in strict accordance with the manufacturer's instructions, may cause interference to radio and television reception. It has been type tested and found to comply with the limits for a Class B computing device in accordance with Part 15 of FCC Rules, which are designed to provide reasonable protection against such interference in a residential installation. However, there is no guarantee that interference will not occur in a particular installation. If this equipment does cause interference to radio or television reception, which can be determined by turning the equipment off and on, the user is encouraged to try to correct the interference by one or more of the following measures:

- Relocate the Console away from the TV/radio receiver.
- Plug the Console into a different wall outlet so that the Console is on a different branch circuit.
- Re-orient the TV/radio antenna.
- If necessary, the user should consult the dealer or an experienced radio/television technician for additional suggestions.